

Barry Waite, Mayor
Bill Uphoff, Mayor Pro Tem
James Gazeley, Council Member
Cindy Segawa, Council Member
Mark A. Waronek, Council Member



LOMITA CITY HALL
COUNCIL CHAMBERS
24300 Narbonne Avenue
Lomita, CA 90717
Phone: (310) 325-7110
Fax: (310) 325-4024

Next Resolution No. 2023-19
Next Ordinance No. 858

**AGENDA
REGULAR MEETING
LOMITA CITY COUNCIL
TUESDAY, SEPTEMBER 19, 2023
6:00 P.M.**

THE CITY COUNCIL HAS RESUMED PUBLIC MEETINGS IN THE COUNCIL CHAMBERS. PARTICIPATION BY MEMBERS OF THE PUBLIC IS ONLY GUARANTEED VIA IN-PERSON ATTENDANCE.

AS A COURTESY, THE CITY WILL ATTEMPT TO ALSO ALLOW PUBLIC PARTICIPATION DURING THE MEETING VIA A COMPUTER OR SMART DEVICE USING THE FOLLOWING ZOOM LINK:

<https://us02web.zoom.us/j/83306576837>

Telephone Option: (669)-900-6833 Meeting ID: 833 0657 6837

Please note that the City cannot, and does not, guarantee that the above Zoom link or dial in feature will work, that any individual commenter's computer or smart device will operate without issue, or that the City's hosting of the Zoom will work without issue. Members of the public acknowledge this and are on notice that public participation is only guaranteed via attendance in Council Chambers and that the Zoom option is provided as a courtesy only. Technological issues or failure of the Zoom link to be operational for any reason will not result in any pause, recess, or cancellation of the meeting.

If you wish to provide public comment during oral communications or for a particular agenda item, you may either contact the City Clerk's Office before the meeting, at 310-325-7110 ext. 141, complete a speaker card and give it to the City Clerk or if participating via Zoom utilize the "raise hand" function to join the queue to speak when the Mayor calls the item for discussion. Your name and city of residency is requested, but not required.

No meeting of the Lomita Public Financing Authority will be held on this date.

1. OPENING CEREMONIES

- a. Call Meeting to Order
- b. Flag Salute
- c. Invocation – Mayor Pro Tem Uphoff
- d. Roll Call
- e. Closed Session Report

2. APPROVAL OF AGENDA

3. PRESENTATIONS

4. ORAL COMMUNICATIONS

Persons wishing to speak on Consent Agenda items or subjects other than those scheduled are requested to do so at this time. In order to conduct a timely meeting, a three (3) minute time limit per person has been established. Government Code Section 54954.2 prohibits the Council from discussing or taking action on a specific item unless it appears on a posted agenda.

5. ORAL COMMUNICATIONS AND MEETING ATTENDANCE REPORTS FROM THE CITY COUNCIL

The City Council may discuss and act upon items described under Council comments; however, items which are not on the agenda will be limited to Council reports, announcements, requests for clarification or factual information, or placement of matters on the agenda for a future meeting.

6. CITY MANAGER’S REPORT (information only)

7. CONSENT AGENDA

All items under the Consent Agenda are considered by the Council to be routine and will be enacted by one motion in the form listed below. There may be separate discussions of these items prior to the time the Council votes on the motion. Specific items may be removed from the Consent Agenda at the request of any Council Member or staff.

RECOMMENDED ACTION: That Consent Agenda Items 7a-k be approved.

- a. Motion to Waive Full Reading of Ordinances and that They be Read in Title Only

RECOMMENDED ACTION: Approve motion.

- b. Warrants/Payroll Register

RECOMMENDED ACTION: Approve and file Warrants/Payroll Register.

- c. Monthly Report for the Administrative Services Department

RECOMMENDED ACTION: Receive and file the report.

- d. Monthly Report for the City Manager's Department

RECOMMENDED ACTION: Receive and file the report.

- e. Monthly Report for the Community and Economic Development Department

RECOMMENDED ACTION: Receive and file the report.

- f. Monthly Report for the Recreation and Facilities Division

RECOMMENDED ACTION: Receive and file the report.

- g. Monthly Report for the Public Works Department

RECOMMENDED ACTION: Receive and file the report.

- h. August 2023 Treasury & Investment Report

RECOMMENDED ACTION: Receive and file the report.

- i. Second Reading and Adoption of Ordinance No. 856 for Zoning Text Amendment No. 2023-07 Amendment Lomita Municipal Code Title XI (Planning and Zoning) to Create Mixed-Use Overlay District Regulations for Four or Fewer Residential Unit Developments within the Downtown, Commercial (D-C) Zone

RECOMMENDED ACTION: Adopt the ordinance and find the project categorically exempt from the California Environmental Quality Act (CEQA).

ORDINANCE NO. 856 - AN ORDINANCE OF THE CITY COUNCIL OF THE CITY OF LOMITA, CALIFORNIA, APPROVING ZONING TEXT AMENDMENT 2023-07 AMENDING LOMITA MUNICIPAL CODE TITLE XI (PLANNING AND ZONING), CHAPTER 1 (ZONING), REVISING THE CITY'S REGULATIONS FOR MIXED-USE OVERLAY DISTRICT TO UPDATE STANDARDS; TO ALLOW MIXED-USE DEVELOPMENTS CONTAINING FOUR OR FEWER UNITS WITHIN THE DOWNTOWN COMMERCIAL (D-C) ZONE; TO DEFINE A TERM AND A DETERMINATION THAT THE PROJECT IS CATEGORICALLY EXEMPT FROM THE CALIFORNIA ENVIRONMENTAL QUALITY ACT (CEQA)

- j. Second Reading and Adoption of Ordinance No. 857 Amending LMC Title V (Sanitation and Health), Chapter 3 (Integrated Waste Management), Section 5-3.20(e), Permitting the Collection of Delinquent Solid Waste Rates on the Property Tax Rolls

RECOMMENDED ACTION: Adopt the ordinance and find the project categorically exempt from the California Environmental Quality Act (CEQA).

ORDINANCE NO. 857 - AN ORDINANCE OF THE CITY COUNCIL OF THE CITY OF LOMITA, CALIFORNIA, AMENDING LOMITA MUNICIPAL CODE TITLE V (SANITATION AND HEALTH), CHAPTER 3 (INTEGRATED WASTE MANAGEMENT), SECTION 5-3.20(e), PERMITTING THE COLLECTION OF DELINQUENT SOLID WASTE RATES ON THE PROPERTY TAX ROLLS, AND A DETERMINATION THAT THE PROJECT IS CATEGORICALLY EXEMPT FROM THE CALIFORNIA ENVIRONMENTAL QUALITY ACT (CEQA)

- k. Professional Services Agreement with Fairbank, Maslin, Maullin, Metz & Associates (FM3) to Conduct a Community Survey

RECOMMENDED ACTION: Authorize the City Manager to execute a Professional Services Agreement with Fairbank, Maslin, Maullin, Metz & Associates (FM3) in an amount not to exceed \$40,000.

8. SCHEDULED ITEMS

- a. **DISCUSSION AND CONSIDERATION OF THE SUNSTONE ECONOMIC DEVELOPMENT CHALLENGE AT USC PRICE**

Presented by Brianna Rindge, Community & Economic Development Director

RECOMMENDED ACTION: Receive and file.

- b. **DISCUSSION AND CONSIDERATION TO AUTHORIZE THE RELEASE OF A BID PACKAGE FOR THE 247TH STREET AREA WATER MAIN REPLACEMENT PROJECT**

Presented by Carla Dillon, P.E., Public Works Director

RECOMMENDED ACTION: Authorize staff to release the bid package for the 247th Street Area Water Main Replacement Project; and find the project categorically exempt from CEQA.

9. PUBLIC HEARINGS

None scheduled.

10. ADJOURNMENT

Written materials distributed to the City Council within 72 hours of the City Council meeting are available for public inspection via the City's website and copies are available for public inspection beginning the next regular business day in the City Clerk's Office, 24300 Narbonne Avenue, Lomita.

In compliance with the Americans with Disabilities Act (ADA) if you need special assistance to participate in this meeting, please contact the office of the City Clerk at (310) 325-7110. Notification at least forty-eight (48) hours prior to the meeting will enable the City to make reasonable arrangements.

I hereby certify under penalty of perjury under the laws of the State of California that the foregoing agenda was posted not less than 72 hours prior to the meeting at the following locations: Lomita City Hall, Lomita Park, and uploaded to the City of Lomita website http://www.lomita.com/cityhall/city_agendas/.

Date Posted: September 14, 2023



Kathleen Horn Gregory, MMC, City Clerk

TO: Honorable Mayor and City Council
FROM: Administrative Services Department
DATE: September 19, 2023
SUBJECT: WARRANT REGISTER
PAYROLL REGISTER

September 19, 2023	TOTAL WARRANTS ISSUED:	\$728,190.77
	Wires Transfers:	10945-10953
	Prepay:	531262-531263
	Check Numbers:	531264-531344

Total Pages of Register: 16

September 8, 2023	TOTAL PAYROLL ISSUED:	\$119,377.41
-------------------	-----------------------	--------------

I hereby certify that the demands or claims covered by the checks listed on pages 1 to 16 inclusive of the check register are accurate and funds are available for payment thereof:



Susan Kamada
Administrative Services Director



Lomita, CA

Warrant Register By Vendor Name

Payment Dates 9/6/2023 - 9/19/2023

Payment Number	Payment Date	Vendor Name	Payable Number	Description (Item)	Amount
Vendor: 6948 - A1 Lawnmower Shop					
531264	09/19/2023	A1 Lawnmower Shop	01130	Fuel Cap for Trimmer	17.64
				Vendor 6948 - A1 Lawnmower Shop Total:	17.64
Vendor: 7353 - ACE Whatever It Takes					
531265	09/19/2023	ACE Whatever It Takes	6042	Misc. Fasteners	6.17
531265	09/19/2023	ACE Whatever It Takes	6042	Sch 40 PVC 1"	20.25
531265	09/19/2023	ACE Whatever It Takes	6044	Misc. Fasteners	5.71
531265	09/19/2023	ACE Whatever It Takes	6044	1/4 in. MPT Brass Nipple	10.97
531265	09/19/2023	ACE Whatever It Takes	6050	Bronze Double Ended Bolt Sn...	11.00
531265	09/19/2023	ACE Whatever It Takes	6051	Liquid Dish Soap 16.2 oz 1 pk	4.40
531265	09/19/2023	ACE Whatever It Takes	6051	1.88" W X 22.2 yd L Moving T...	5.06
531265	09/19/2023	ACE Whatever It Takes	6051	175 ft. L Galvanized Steel 20 G...	5.50
531265	09/19/2023	ACE Whatever It Takes	6051	Liquid Dish Soap 19.4 oz	6.60
531265	09/19/2023	ACE Whatever It Takes	6051	Misc. Fasteners	8.77
531265	09/19/2023	ACE Whatever It Takes	6051	Snips Multipurpose 10"	16.53
531265	09/19/2023	ACE Whatever It Takes	6051	Motor Oil 10W40 QT	7.71
531265	09/19/2023	ACE Whatever It Takes	6064	Picture Hang Strips 12-Pk	26.44
531265	09/19/2023	ACE Whatever It Takes	6065	Tape Measure 25X1"	15.42
531265	09/19/2023	ACE Whatever It Takes	6065	Washer Hose Rubber 10-Pk	3.30
531265	09/19/2023	ACE Whatever It Takes	6067	Light Bulb LED 6-Pk	35.27
531265	09/19/2023	ACE Whatever It Takes	6067	1.25 in. W X 16 ft. L Camo Tie ...	35.27
				Vendor 7353 - ACE Whatever It Takes Total:	224.37
Vendor: 12207 - AKM Consulting Engineers, Inc.					
531266	09/19/2023	AKM Consulting Engineers, Inc.	0012395	Consulting Sevices for CWP... ..	2,400.00
				Vendor 12207 - AKM Consulting Engineers, Inc. Total:	2,400.00
Vendor: 7445 - All City Management Services, Inc.					
531267	09/19/2023	All City Management Services, ..	87404	Crossing Guard Services	4,625.28
				Vendor 7445 - All City Management Services, Inc. Total:	4,625.28
Vendor: 0545 - Allied Waste Transfer Services (BFI Falcon TS)					
531268	09/19/2023	Allied Waste Transfer Services ..	4404-000021994	Park-Dump Fee	641.21
531268	09/19/2023	Allied Waste Transfer Services ..	4404-000021994	Park-Dump Fee	885.53
531268	09/19/2023	Allied Waste Transfer Services ..	4404-000021994	Tree-Dump Fee	204.84
531268	09/19/2023	Allied Waste Transfer Services ..	4404-000021994	Tree-Dump Fee	215.51
531268	09/19/2023	Allied Waste Transfer Services ..	4404-000021994	Water-Dump Fee	1,825.46
				Vendor 0545 - Allied Waste Transfer Services (BFI Falcon TS) Total:	3,772.55
Vendor: 12155 - Amazon Capital Services					
531269	09/19/2023	Amazon Capital Services	1RFY-RLJH-QMJC	Toner Cartridge	286.64
531269	09/19/2023	Amazon Capital Services	1W6X-GQ11-X37C	Portable Battery Operated M...	19.83
531269	09/19/2023	Amazon Capital Services	1W6X-GQ11-X37C	Desk Organizer and Accessori...	24.24
531269	09/19/2023	Amazon Capital Services	1W6X-GQ11-X37C	18 Pack Decorative File Folders	17.63
531269	09/19/2023	Amazon Capital Services	1W6X-GQ11-X37C	Wide Rule Lined Writing Note...	20.10
531269	09/19/2023	Amazon Capital Services	1WTP-VNFX-YQFM	Color Ribbon Load-N-Go Print...	44.00
531269	09/19/2023	Amazon Capital Services	1X64-GMPW-LV6Y	Socket Extensions Adapter	57.31
531269	09/19/2023	Amazon Capital Services	1X64-GMPW-LV6Y	1000W Equivalent LED Corn B...	654.11
				Vendor 12155 - Amazon Capital Services Total:	1,123.86
Vendor: 4010 - Ameritas Life Insurance					
531270	09/19/2023	Ameritas Life Insurance	September 23	Employee Dental Insurance-S...	2,922.53
531270	09/19/2023	Ameritas Life Insurance	September 23	Employee Dental Insurance-S...	94.13
531270	09/19/2023	Ameritas Life Insurance	September 23	Employee Dental Insurance-S...	73.78
531270	09/19/2023	Ameritas Life Insurance	September 23	Employee Dental Insurance-S...	76.32
531270	09/19/2023	Ameritas Life Insurance	September 23	Employee Dental Insurance-S...	53.33
531270	09/19/2023	Ameritas Life Insurance	September 23	Employee Dental Insurance-S...	152.64

Warrant Register

Payment Dates: 9/6/2023 - 9/19/2023

Payment Number	Payment Date	Vendor Name	Payable Number	Description (Item)	Amount
531270	09/19/2023	Ameritas Life Insurance	September 23	Employee Dental Insurance-S...	72.46
531270	09/19/2023	Ameritas Life Insurance	September 23	Employee Dental Insurance-S...	61.06
531270	09/19/2023	Ameritas Life Insurance	September 23	Employee Dental Insurance-S...	101.76
531270	09/19/2023	Ameritas Life Insurance	September 23	Employee Dental Insurance-S...	96.67
531270	09/19/2023	Ameritas Life Insurance	September 23	Employee Dental Insurance-S...	180.62
531270	09/19/2023	Ameritas Life Insurance	September 23	Employee Dental Insurance-S...	101.76
531270	09/19/2023	Ameritas Life Insurance	September 23	Employee Dental Insurance-S...	7.63
531270	09/19/2023	Ameritas Life Insurance	September 23	Employee Dental Insurance-S...	5.09
531270	09/19/2023	Ameritas Life Insurance	September 23	Employee Dental Insurance-S...	7.63
531270	09/19/2023	Ameritas Life Insurance	September 23	Employee Dental Insurance-S...	20.35
531270	09/19/2023	Ameritas Life Insurance	September 23	Employee Dental Insurance-S...	76.32
531270	09/19/2023	Ameritas Life Insurance	September 23	Employee Dental Insurance-S...	53.33
531270	09/19/2023	Ameritas Life Insurance	September 23	Employee Dental Insurance-S...	605.79
Vendor 4010 - Ameritas Life Insurance				Total:	4,763.20

Vendor: 0285 - Amtech Elevator Services

531271	09/19/2023	Amtech Elevator Services	F10000118877	Logistics & Fuel Impact Fee	100.00
Vendor 0285 - Amtech Elevator Services				Total:	100.00

Vendor: 0375 - Astro Auto & Electric

531272	09/19/2023	Astro Auto & Electric	16946	Starter Replacement for Club ...	297.68
Vendor 0375 - Astro Auto & Electric				Total:	297.68

Vendor: 6609 - AT&T

531273	09/19/2023	AT&T	20492169	City Hall & Park August 23	486.59
531273	09/19/2023	AT&T	20492169	Water August 23	50.90
531273	09/19/2023	AT&T	20492171	Railroad Museum August 23	26.20
531273	09/19/2023	AT&T	20492571	City Hall August 23	20.12
Vendor 6609 - AT&T				Total:	583.81

Vendor: 4020 - Automatic Data Processing

10951	09/08/2023	Automatic Data Processing	641506759	Workforce Time and Attendan...	713.36
10951	09/08/2023	Automatic Data Processing	641506759	Workforce Time and Attendan...	237.79
Vendor 4020 - Automatic Data Processing				Total:	951.15

Vendor: 3334 - Autozone, Inc.

531274	09/19/2023	Autozone, Inc.	2859732946	Reese 2.5"-2" Reducer Sleeve	19.90
531274	09/19/2023	Autozone, Inc.	2859732946	Reese Tactical 5/8" Pin & Clip ...	15.42
531274	09/19/2023	Autozone, Inc.	2859732946	Black Heavy Duty Mats	45.74
531274	09/19/2023	Autozone, Inc.	2859749941	Coolant	23.14
531274	09/19/2023	Autozone, Inc.	2859751550	Quick Fill Funnel	8.70
531274	09/19/2023	Autozone, Inc.	2859759502	10W-40 Motor Oil	26.17
531274	09/19/2023	Autozone, Inc.	2859759587	Battery Cleaner, Acid Detector	5.02
531274	09/19/2023	Autozone, Inc.	2859759587	20 ft Booster Cables	62.50
Vendor 3334 - Autozone, Inc.				Total:	206.59

Vendor: 7477 - Best Best & Krieger, LLP

531275	09/19/2023	Best Best & Krieger, LLP	973496	Special Services July 23	15,491.20
531275	09/19/2023	Best Best & Krieger, LLP	973497	Legal Services July 23	5,364.01
531275	09/19/2023	Best Best & Krieger, LLP	973497	Legal Services July 23	946.59
531275	09/19/2023	Best Best & Krieger, LLP	973498	Code Enforcement/General Lit...	3,546.20
Vendor 7477 - Best Best & Krieger, LLP				Total:	25,348.00

Vendor: 12810 - California Greenhouses & OC Succulents

531276	09/19/2023	California Greenhouses & OC ...	201-47231	10"/5G Cordyline Paso Doble	93.23
531276	09/19/2023	California Greenhouses & OC ...	201-47402	10"/5G Cordyline Pink Passion	56.06
531276	09/19/2023	California Greenhouses & OC ...	201-47402	10"/5G Cordyline Paso Doble	18.69
531276	09/19/2023	California Greenhouses & OC ...	201-47402	10"/5G Agave Attenuata	69.13
531276	09/19/2023	California Greenhouses & OC ...	201-47459	15G Aloe Medusa	166.02
531276	09/19/2023	California Greenhouses & OC ...	201-47459	10"/5G Echeveria Afterglow	34.73
Vendor 12810 - California Greenhouses & OC Succulents Total:				Total:	437.86

Vendor: 7319 - California State Disbursement Unit

531277	09/19/2023	California State Disbursement...	092223	Employee Garnishment-Pay D...	230.76
Vendor 7319 - California State Disbursement Unit				Total:	230.76

Warrant Register

Payment Dates: 9/6/2023 - 9/19/2023

Payment Number	Payment Date	Vendor Name	Payable Number	Description (Item)	Amount
Vendor: 0655 - California Water Service					
531278	09/19/2023	California Water Service	6984422222-082923	PV Dr. No. Rolling Vista Media...	264.77
531278	09/19/2023	California Water Service	8594422222-082523	Landscape Maint. District #1	167.45
Vendor 0655 - California Water Service Total:					432.22
Vendor: 4657 - Carlos Bobadilla					
531279	09/19/2023	Carlos Bobadilla	062923	Mileage & Expenses Reimburs...	194.10
531279	09/19/2023	Carlos Bobadilla	081323	Mileage Reimbursement	128.38
Vendor 4657 - Carlos Bobadilla Total:					322.48
Vendor: 6642 - Catalina Pacific Concrete					
531280	09/19/2023	Catalina Pacific Concrete	96033218	Concrete	1,069.04
Vendor 6642 - Catalina Pacific Concrete Total:					1,069.04
Vendor: 12822 - City of Lomita - Petty Cash					
531281	09/19/2023	City of Lomita - Petty Cash	August 23	SBCCOG City Manager's Meeti...	40.00
531281	09/19/2023	City of Lomita - Petty Cash	August 23	Facilities Towels	27.35
Vendor 12822 - City of Lomita - Petty Cash Total:					67.35
Vendor: 6751 - Conico Roro, Inc.					
531282	09/19/2023	Conico Roro, Inc.	083123	Car Wash	33.00
531282	09/19/2023	Conico Roro, Inc.	083123	Facility	125.13
531282	09/19/2023	Conico Roro, Inc.	083123	Park	145.17
531282	09/19/2023	Conico Roro, Inc.	083123	Street	1,256.35
531282	09/19/2023	Conico Roro, Inc.	083123	Water	887.14
Vendor 6751 - Conico Roro, Inc. Total:					2,446.79
Vendor: 0915 - Copy Rite Printing					
531283	09/19/2023	Copy Rite Printing	39637	Business Cards-S. Ritchie	41.56
Vendor 0915 - Copy Rite Printing Total:					41.56
Vendor: 7371 - Corporate Payment Systems					
531284	09/19/2023	Corporate Payment Systems	C. Villa 082523	Canva Subscription	12.99
531284	09/19/2023	Corporate Payment Systems	C. Villa 082523	Chalk for Baseball Field	52.35
531284	09/19/2023	Corporate Payment Systems	D. Dixon 082523	3 Gift Cards for Rater Panels	45.00
531284	09/19/2023	Corporate Payment Systems	D. Dixon 082523	JPIA Harassment Prevention R...	106.46
531284	09/19/2023	Corporate Payment Systems	D. Dixon 082523	Online Harassment Prevention..	27.00
531284	09/19/2023	Corporate Payment Systems	D. Dixon 082523	Online Harassment Prevention..	27.00
531284	09/19/2023	Corporate Payment Systems	D. Dixon 082523	Online Harassment Prevention..	27.00
531284	09/19/2023	Corporate Payment Systems	D. Dixon 082523-Credit	Cal PERS Training Cancellation	-449.00
531284	09/19/2023	Corporate Payment Systems	G. Sugano 082523	Acrobat Pro	695.71
531284	09/19/2023	Corporate Payment Systems	G. Sugano 082523	Zoom Video	15.99
531284	09/19/2023	Corporate Payment Systems	G. Sugano 082523	Laptop, ThinkPad P15 Gen 2 In...	1,654.71
531284	09/19/2023	Corporate Payment Systems	H. Flores 082523	Coffee Supplies	87.41
531284	09/19/2023	Corporate Payment Systems	H. Flores 082523	Landscape Equipment Repairs	159.54
531284	09/19/2023	Corporate Payment Systems	J. Vida 082523	Staff Meeting Lunch	163.56
531284	09/19/2023	Corporate Payment Systems	J. Vida 082523	Water for Staff Meeting	17.48
531284	09/19/2023	Corporate Payment Systems	J. Vida 082523	Ice Staff Meeting	7.03
531284	09/19/2023	Corporate Payment Systems	J. Vida 082523	Zoom Video	149.90
531284	09/19/2023	Corporate Payment Systems	J. Vida 082523	Basketball Certificates	96.33
531284	09/19/2023	Corporate Payment Systems	K. Gregory 082523	Annual Conference Lunch-W. ...	75.00
531284	09/19/2023	Corporate Payment Systems	K. Gregory 082523	City Council Meeting Dinner	116.48
531284	09/19/2023	Corporate Payment Systems	K. Gregory 082523	Daily Breeze Subscription	10.00
531284	09/19/2023	Corporate Payment Systems	K. Gregory 082523	Dropbox	19.99
531284	09/19/2023	Corporate Payment Systems	Lomita Park 082523	Daily Breeze Subscription-52 ...	338.00
531284	09/19/2023	Corporate Payment Systems	Lomita Park 082523	Daily Breeze Subscription	70.57
531284	09/19/2023	Corporate Payment Systems	Lomita Park 082523	JPIA Meeting Refreshment	30.48
531284	09/19/2023	Corporate Payment Systems	Lomita Park 082523	JPIA Meeting Refreshment	30.36
531284	09/19/2023	Corporate Payment Systems	Lomita Park 082523	Survey Monkey Plan	468.00
531284	09/19/2023	Corporate Payment Systems	Lomita Park 082523	Mailing Service	23.30
531284	09/19/2023	Corporate Payment Systems	Lomita Park 082523	Teen Program-Food	99.61
531284	09/19/2023	Corporate Payment Systems	Lomita Park 082523	Teen Program Supplies	65.10
531284	09/19/2023	Corporate Payment Systems	Lomita Park 082523	Teen Program-Knott's Berry F...	90.00
531284	09/19/2023	Corporate Payment Systems	Lomita Park 082523	Ice Cream for LASD BBQ	246.40

Warrant Register

Payment Dates: 9/6/2023 - 9/19/2023

Payment Number	Payment Date	Vendor Name	Payable Number	Description (Item)	Amount
531284	09/19/2023	Corporate Payment Systems	Lomita Park 082523	Museum-T-Shirts for Resale	954.10
531284	09/19/2023	Corporate Payment Systems	M. Andersen 082523	Online Harassment Prevention	27.00
531284	09/19/2023	Corporate Payment Systems	M. Andersen 082523	Office Supplies	147.07
531284	09/19/2023	Corporate Payment Systems	M. Andersen 082523	Work Pants-D. Huerta	115.73
531284	09/19/2023	Corporate Payment Systems	M. Andersen 082523	Work Pants-M. Andersen	144.49
531284	09/19/2023	Corporate Payment Systems	M. Andersen 082523	Work Pants-M. Stolz	33.06
531284	09/19/2023	Corporate Payment Systems	M. Andersen 082523	40" Meter Soil Sampler Probe ...	88.19
531284	09/19/2023	Corporate Payment Systems	M. Andersen 082523	Car Seat Covers	77.06
531284	09/19/2023	Corporate Payment Systems	M. Andersen 082523	Staff Lunch	118.47
531284	09/19/2023	Corporate Payment Systems	M. Andersen 082523	Staff Lunch	39.95
531284	09/19/2023	Corporate Payment Systems	M. Andersen 082523	Staff Lunch	62.63
531284	09/19/2023	Corporate Payment Systems	M. Sansbury 082523	Pesticide Applicators Member...	70.00
531284	09/19/2023	Corporate Payment Systems	M. Sansbury 082523	Pesticide Applicators Seminar...	100.00
531284	09/19/2023	Corporate Payment Systems	M. Sansbury 082523	Pest School Course-M. Sansbu...	20.00
531284	09/19/2023	Corporate Payment Systems	M. Sansbury 082523	Colorado Truck Floor Mats	203.50
531284	09/19/2023	Corporate Payment Systems	M. Sansbury 082523	Mass Mobile Apps	99.00
531284	09/19/2023	Corporate Payment Systems	M. Sansbury 082523	Movie Under the Stars-Staff D...	32.01
531284	09/19/2023	Corporate Payment Systems	M. Sansbury 082523	National Night Out-Staff Dinner	41.60
531284	09/19/2023	Corporate Payment Systems	S. Kamada 082523	Engaged Public Finance Workf...	70.00
				Vendor 7371 - Corporate Payment Systems	Total: 7,023.61
Vendor: 12721 - Cory Zedler					
531285	09/19/2023	Cory Zedler	083123	Mileage Reimbursement	19.98
				Vendor 12721 - Cory Zedler Total:	19.98
Vendor: 6828 - Creative Software Solutions					
531286	09/19/2023	Creative Software Solutions	CINV-039488	DAR August 23	483.33
				Vendor 6828 - Creative Software Solutions	Total: 483.33
Vendor: 12904 - Cristina Allred					
531287	09/19/2023	Cristina Allred	2004190.001	Refund-Tom Rico Center Depo...	200.00
				Vendor 12904 - Cristina Allred Total:	200.00
Vendor: 6757 - Dataprose, Inc.					
531288	09/19/2023	Dataprose, Inc.	DP2303490	Water Bills	484.99
531288	09/19/2023	Dataprose, Inc.	DP2303490	Leak Letters	231.63
				Vendor 6757 - Dataprose, Inc.	Total: 716.62
Vendor: 12704 - David Evans & Associates, Inc.					
531289	09/19/2023	David Evans & Associates, Inc.	543809	Engineering Design-Street Rec...	8,227.50
531289	09/19/2023	David Evans & Associates, Inc.	543810	Engineering Design Services-N...	225.00
531289	09/19/2023	David Evans & Associates, Inc.	543810	Engineering Design Services-N...	225.00
531289	09/19/2023	David Evans & Associates, Inc.	543810	Engineering Design Services-N...	11,636.00
				Vendor 12704 - David Evans & Associates, Inc. Total:	20,313.50
Vendor: 12883 - De Novo Planning Group					
531290	09/19/2023	De Novo Planning Group	3932	Lomita General Plan Update	114,977.50
				Vendor 12883 - De Novo Planning Group Total:	114,977.50
Vendor: 7438 - Duke Service Center, Inc.					
531291	09/19/2023	Duke Service Center, Inc.	083123	Park	1,339.98
531291	09/19/2023	Duke Service Center, Inc.	083123	Street	752.95
				Vendor 7438 - Duke Service Center, Inc.	Total: 2,092.93
Vendor: 12903 - Elisa Bautista					
531292	09/19/2023	Elisa Bautista	2004189.001	Refund-Picnic Shelter Deposit-...	40.00
				Vendor 12903 - Elisa Bautista Total:	40.00
Vendor: 12696 - Gary Guttormson					
531293	09/19/2023	Gary Guttormson	2004188.001	Refund-Picnic Shelter Deposit-...	40.00
				Vendor 12696 - Gary Guttormson Total:	40.00
Vendor: 12902 - Gen-Tech					
531294	09/19/2023	Gen-Tech	05-87681-1	Industrial Outdoor Diesel Gen...	19,593.69
				Vendor 12902 - Gen-Tech Total:	19,593.69
Vendor: 3070 - Grainger					
531295	09/19/2023	Grainger	9813413904	Ball Valve	380.61

Warrant Register

Payment Dates: 9/6/2023 - 9/19/2023

Payment Number	Payment Date	Vendor Name	Payable Number	Description (Item)	Amount
531295	09/19/2023	Grainger	9813413904	Coil Tubing, Welded 1/4", 50'	75.40
531295	09/19/2023	Grainger	9815910113	Jobber Drill 3/32"	6.48
531295	09/19/2023	Grainger	9815910113	Jobber Drill 1/16"	6.32
531295	09/19/2023	Grainger	9815910121	Connector	244.84
531295	09/19/2023	Grainger	9815910121	Ratcheting Tubing Bender Set,...	259.20
				Vendor 3070 - Grainger	Total: 972.85
Vendor: 7118 - Gruber and Lopez, Inc.					
531296	09/19/2023	Gruber and Lopez, Inc.	4574	FY 2022-23 Interim Audit 1st B...	2,000.00
531296	09/19/2023	Gruber and Lopez, Inc.	4574	FY 2022-23 Interim Audit 1st B...	2,000.00
				Vendor 7118 - Gruber and Lopez, Inc.	Total: 4,000.00
Vendor: 7144 - Hazen and Sawyer, P.C.					
531297	09/19/2023	Hazen and Sawyer, P.C.	20007-010-0000032	Consulting Services-CWPF	597.50
				Vendor 7144 - Hazen and Sawyer, P.C.	Total: 597.50
Vendor: 12905 - High Point Electric					
531298	09/19/2023	High Point Electric	083023	Refund Processing Fee for Ho...	53.75
				Vendor 12905 - High Point Electric Total:	53.75
Vendor: 3241 - Hinderliter, De Llamas & Associates					
531299	09/19/2023	Hinderliter, De Llamas & Assoc..	SIN031142	Sales Tax	2,034.39
531299	09/19/2023	Hinderliter, De Llamas & Assoc..	SIN031267	Sales Tax	1,330.60
				Vendor 3241 - Hinderliter, De Llamas & Associates	Total: 3,364.99
Vendor: 3052 - Home Depot Credit Services					
531300	09/19/2023	Home Depot Credit Services	0614429	12" Adjustable Wrench	27.53
531300	09/19/2023	Home Depot Credit Services	0614429	3/8" Universal Socket with Po...	13.20
531300	09/19/2023	Home Depot Credit Services	0614429	Combo Round Head Stainless ...	1.52
531300	09/19/2023	Home Depot Credit Services	0614429	6" Bench Wire Wheel Coarse	9.59
531300	09/19/2023	Home Depot Credit Services	0614429	Grit Steel Demon Grinding and..	10.44
531300	09/19/2023	Home Depot Credit Services	0614429	Small Organizer	25.34
531300	09/19/2023	Home Depot Credit Services	0614429	10-Compartment Deep Pro S...	27.54
531300	09/19/2023	Home Depot Credit Services	0614429	Plated Double Hinge Safety Ha...	5.23
531300	09/19/2023	Home Depot Credit Services	0614429	3" Wire Cup Brush	6.91
531300	09/19/2023	Home Depot Credit Services	1973376	Pallet Deposit	25.00
531300	09/19/2023	Home Depot Credit Services	1973376	Concrete Mix	226.50
531300	09/19/2023	Home Depot Credit Services	1973376	Discount	-20.72
531300	09/19/2023	Home Depot Credit Services	2030791	Water Bottle Deposit	8.40
531300	09/19/2023	Home Depot Credit Services	2030791	Bottle Water 24-Pk	34.86
531300	09/19/2023	Home Depot Credit Services	2030791	Adjustable Wrench	13.20
531300	09/19/2023	Home Depot Credit Services	2030791	6 in. Adjustable Wrench	7.68
531300	09/19/2023	Home Depot Credit Services	2030791	Fast Back Flip Utility Knife 2-Pk	22.02
531300	09/19/2023	Home Depot Credit Services	2030791	Heavy Duty Utility Blade 100-...	17.61
531300	09/19/2023	Home Depot Credit Services	2030791	169 oz Purple Multi-Purpose C...	11.00
531300	09/19/2023	Home Depot Credit Services	2030791	Angled Sash Paint Brush	10.99
531300	09/19/2023	Home Depot Credit Services	2030791	Thin Angle Sash Brush	15.95
531300	09/19/2023	Home Depot Credit Services	2030791	Air Freshener Refill 2-Count	13.21
531300	09/19/2023	Home Depot Credit Services	2030791	19 oz. Crisp Linen Disinfectant...	33.03
531300	09/19/2023	Home Depot Credit Services	2030791	Paper Towel Roll 12 Double	35.81
531300	09/19/2023	Home Depot Credit Services	2030791	Toilet Paper 30 Mega Roll	41.15
531300	09/19/2023	Home Depot Credit Services	2030791	16 ft. x 20 ft. Brown/Silver He...	78.59
531300	09/19/2023	Home Depot Credit Services	2030791	Biner Stainless Steel 3-Pk	10.82
531300	09/19/2023	Home Depot Credit Services	2030791	Brush Comb	4.27
531300	09/19/2023	Home Depot Credit Services	2093609	Blend Mop Head Refill 2-Pk	19.26
531300	09/19/2023	Home Depot Credit Services	2093609	50 qt. Potting Soil Mix	18.58
531300	09/19/2023	Home Depot Credit Services	2093609	Economy Cotton Mop Refill 3-...	18.16
531300	09/19/2023	Home Depot Credit Services	2512753	1/2" MIP X 1/4" Pipe Bushing	6.13
531300	09/19/2023	Home Depot Credit Services	3524256	Husky 11 pc 1/4" and 3/8" Tor...	28.63
531300	09/19/2023	Home Depot Credit Services	3524256	Husky 5 pc Torx Screw Driver ...	15.40
531300	09/19/2023	Home Depot Credit Services	3524256	Time-Delay Cartridge Fuses 2-...	29.19
531300	09/19/2023	Home Depot Credit Services	3524256	Work Gloves	15.87
531300	09/19/2023	Home Depot Credit Services	3820509	100-Wattt/140-Watt Soldering	64.90
531300	09/19/2023	Home Depot Credit Services	4642846	5-in-1 Gloss Smoke Gray Spray...	8.80

Warrant Register

Payment Dates: 9/6/2023 - 9/19/2023

Payment Number	Payment Date	Vendor Name	Payable Number	Description (Item)	Amount
531300	09/19/2023	Home Depot Credit Services	4642846	Stops Rust Metal Primer	23.09
531300	09/19/2023	Home Depot Credit Services	4642846	5-in-1 Gloss Charcoal Gray Spr...	17.46
531300	09/19/2023	Home Depot Credit Services	4642846	Spray Paint	11.00
531300	09/19/2023	Home Depot Credit Services	9020615	14" X 25" Sand Bags	59.42
				Vendor 3052 - Home Depot Credit Services	Total: 1,052.56
Vendor: 12908 - Horn's Collision Center					
531301	09/19/2023	Horn's Collision Center	7427	2023 Nissan Leaf Repair-Labor	2,534.00
531301	09/19/2023	Horn's Collision Center	7427	2023 Nissan Leaf Repair-Parts	582.66
531301	09/19/2023	Horn's Collision Center	7427	2023 Nissan Leaf Repair-Misce...	95.00
531301	09/19/2023	Horn's Collision Center	7427	2023 Nissan Leaf Repair-Mech...	130.00
531301	09/19/2023	Horn's Collision Center	7427	2023 Nissan Leaf Repair-Paint	898.71
				Vendor 12908 - Horn's Collision Center Total:	4,240.37
Vendor: 12900 - Joel Arellano					
531302	09/19/2023	Joel Arellano	2004177.001	Refund-Gymnasium Deposit- ...	100.00
				Vendor 12900 - Joel Arellano Total:	100.00
Vendor: 12596 - Jorge Calderon					
531303	09/19/2023	Jorge Calderon	081323	Mileage Reimbursement	128.38
				Vendor 12596 - Jorge Calderon Total:	128.38
Vendor: 12635 - Kiley & Associates, LLC					
531304	09/19/2023	Kiley & Associates, LLC	LO 230831	Consulting Services	3,333.33
				Vendor 12635 - Kiley & Associates, LLC Total:	3,333.33
Vendor: 3507 - L&B Pipe and Supply Co.					
531305	09/19/2023	L&B Pipe and Supply Co.	S115999944.001	Kohler Venza Faucet	453.27
				Vendor 3507 - L&B Pipe and Supply Co. Total:	453.27
Vendor: 3331 - Lee's Tires					
531306	09/19/2023	Lee's Tires	81306	2023 Nissan Leaf Tire Repair	20.00
				Vendor 3331 - Lee's Tires Total:	20.00
Vendor: 12839 - Linda Okumura					
531307	09/19/2023	Linda Okumura	090623	Line Dancing Class Instructor	3,251.50
				Vendor 12839 - Linda Okumura Total:	3,251.50
Vendor: 3054 - Linde Gas & Equipment Inc.					
531308	09/19/2023	Linde Gas & Equipment Inc.	37778510	Acetylene Torch Rental	65.37
				Vendor 3054 - Linde Gas & Equipment Inc. Total:	65.37
Vendor: 3903 - Lomita City Employees Association					
531309	09/19/2023	Lomita City Employees Associa...	September 23	Association Dues-September ...	600.00
				Vendor 3903 - Lomita City Employees Association Total:	600.00
Vendor: 3095 - Lomita Railroad Museum Foundation					
10952	09/12/2023	Lomita Railroad Museum Fou...	083123	Museum Foundation Revenue...	588.69
				Vendor 3095 - Lomita Railroad Museum Foundation Total:	588.69
Vendor: 6110 - Loprest, Division of WRT					
531310	09/19/2023	Loprest, Division of WRT	0923-01	Filter Inspection at CWPF	3,255.00
531310	09/19/2023	Loprest, Division of WRT	0923-01	Filter Inspection at CWPF-Trav...	633.91
				Vendor 6110 - Loprest, Division of WRT Total:	3,888.91
Vendor: 12896 - Loretta Calas					
531311	09/19/2023	Loretta Calas	2004176.001	Refund Account Credit Balanc...	145.00
				Vendor 12896 - Loretta Calas Total:	145.00
Vendor: 6020 - Mark Waronek					
531312	09/19/2023	Mark Waronek	090423	Reimbursement for Mileage, ...	426.70
				Vendor 6020 - Mark Waronek Total:	426.70
Vendor: 3085 - Mark's Lock & Safe, Inc.					
531313	09/19/2023	Mark's Lock & Safe, Inc.	0000036623	Cameras & Parts	2,810.72
531313	09/19/2023	Mark's Lock & Safe, Inc.	0000036623	Install Cameras-Labor	3,622.50
				Vendor 3085 - Mark's Lock & Safe, Inc. Total:	6,433.22
Vendor: 7247 - Michael Baker International, Inc.					
531314	09/19/2023	Michael Baker International, I...	1189944	Consulting Services-CDBG Reh...	1,550.00

Warrant Register

Payment Dates: 9/6/2023 - 9/19/2023

Payment Number	Payment Date	Vendor Name	Payable Number	Description (Item)	Amount
531314	09/19/2023	Michael Baker International, I...	1189944	Consulting Services-CDBG Lifel...	3,410.00
Vendor 7247 - Michael Baker International, Inc. Total:					4,960.00
Vendor: 4558 - Michael McDaniel					
531315	09/19/2023	Michael McDaniel	073123	GIS Services July 23	90.00
Vendor 4558 - Michael McDaniel Total:					90.00
Vendor: 12899 - Michelle Birch					
531316	09/19/2023	Michelle Birch	2004178.001	Refund-Picnic Shelter Deposit-...	40.00
Vendor 12899 - Michelle Birch Total:					40.00
Vendor: 3217 - MissionSquare Retirement					
10947	09/06/2023	MissionSquare Retirement	PD090823	Deferred Compensation Pay D...	11,840.84
10947	09/06/2023	MissionSquare Retirement	PD090823	Deferred Compensation Pay D...	365.26
10947	09/06/2023	MissionSquare Retirement	PD090823	Deferred Compensation Pay D...	330.87
10947	09/06/2023	MissionSquare Retirement	PD090823	Deferred Compensation Pay D...	137.84
10947	09/06/2023	MissionSquare Retirement	PD090823	Deferred Compensation Pay D...	157.29
10947	09/06/2023	MissionSquare Retirement	PD090823	Deferred Compensation Pay D...	362.77
10947	09/06/2023	MissionSquare Retirement	PD090823	Deferred Compensation Pay D...	174.55
10947	09/06/2023	MissionSquare Retirement	PD090823	Deferred Compensation Pay D...	269.50
10947	09/06/2023	MissionSquare Retirement	PD090823	Deferred Compensation Pay D...	257.10
10947	09/06/2023	MissionSquare Retirement	PD090823	Deferred Compensation Pay D...	238.20
10947	09/06/2023	MissionSquare Retirement	PD090823	Deferred Compensation Pay D...	292.36
10947	09/06/2023	MissionSquare Retirement	PD090823	Deferred Compensation Pay D...	234.78
10947	09/06/2023	MissionSquare Retirement	PD090823	Deferred Compensation Pay D...	29.14
10947	09/06/2023	MissionSquare Retirement	PD090823	Deferred Compensation Pay D...	15.19
10947	09/06/2023	MissionSquare Retirement	PD090823	Deferred Compensation Pay D...	12.71
10947	09/06/2023	MissionSquare Retirement	PD090823	Deferred Compensation Pay D...	90.00
10947	09/06/2023	MissionSquare Retirement	PD090823	Deferred Compensation Pay D...	139.01
10947	09/06/2023	MissionSquare Retirement	PD090823	Deferred Compensation Pay D...	157.29
10947	09/06/2023	MissionSquare Retirement	PD090823	Deferred Compensation Pay D...	1,127.61
Vendor 3217 - MissionSquare Retirement Total:					16,232.31
Vendor: 12906 - MR Designs Printing LLC					
531317	09/19/2023	MR Designs Printing LLC	4103	Polo Shirts	59.14
Vendor 12906 - MR Designs Printing LLC Total:					59.14
Vendor: 7496 - Numa Networks					
531318	09/19/2023	Numa Networks	35002	Migrate Incode to Cloud	2,100.00
531318	09/19/2023	Numa Networks	35045	IT Services September 23	4,991.58
531318	09/19/2023	Numa Networks	35045	IT Services September 23	4,991.57
Vendor 7496 - Numa Networks Total:					12,083.15
Vendor: 6594 - Office Depot Business Solutions, LLC					
531319	09/19/2023	Office Depot Business Solutio...	328078856001	Copy Paper	109.13
531319	09/19/2023	Office Depot Business Solutio...	328078856001	Scotch Tape	9.81
531319	09/19/2023	Office Depot Business Solutio...	328311715001	Battery AA 24-Pk	18.76
531319	09/19/2023	Office Depot Business Solutio...	32831483001	Sign Frames with Suction Cups...	58.42
531319	09/19/2023	Office Depot Business Solutio...	328391960001	Brother Toner, TN223 Black	57.15
Vendor 6594 - Office Depot Business Solutions, LLC Total:					253.27
Vendor: 4105 - Pacific Western Bank					
10948	09/07/2023	Pacific Western Bank	PE090123	Federal & Medicare Taxes-Pay...	15,965.29
10948	09/07/2023	Pacific Western Bank	PE090123	Federal & Medicare Taxes-Pay...	2,291.90
10948	09/07/2023	Pacific Western Bank	PE090123	Federal & Medicare Taxes-Pay...	9.48
10948	09/07/2023	Pacific Western Bank	PE090123	Federal & Medicare Taxes-Pay...	254.91
10948	09/07/2023	Pacific Western Bank	PE090123	Federal & Medicare Taxes-Pay...	101.55
10948	09/07/2023	Pacific Western Bank	PE090123	Federal & Medicare Taxes-Pay...	145.29
10948	09/07/2023	Pacific Western Bank	PE090123	Federal & Medicare Taxes-Pay...	65.94
10948	09/07/2023	Pacific Western Bank	PE090123	Federal & Medicare Taxes-Pay...	29.45
10948	09/07/2023	Pacific Western Bank	PE090123	Federal & Medicare Taxes-Pay...	21.30
10948	09/07/2023	Pacific Western Bank	PE090123	Federal & Medicare Taxes-Pay...	34.18
10948	09/07/2023	Pacific Western Bank	PE090123	Federal & Medicare Taxes-Pay...	8.47
10948	09/07/2023	Pacific Western Bank	PE090123	Federal & Medicare Taxes-Pay...	223.09
10948	09/07/2023	Pacific Western Bank	PE090123	Federal & Medicare Taxes-Pay...	93.77

Warrant Register

Payment Dates: 9/6/2023 - 9/19/2023

Payment Number	Payment Date	Vendor Name	Payable Number	Description (Item)	Amount
10948	09/07/2023	Pacific Western Bank	PE090123	Federal & Medicare Taxes-Pay...	10.91
10948	09/07/2023	Pacific Western Bank	PE090123	Federal & Medicare Taxes-Pay...	115.92
10948	09/07/2023	Pacific Western Bank	PE090123	Federal & Medicare Taxes-Pay...	20.01
10948	09/07/2023	Pacific Western Bank	PE090123	Federal & Medicare Taxes-Pay...	90.57
10948	09/07/2023	Pacific Western Bank	PE090123	Federal & Medicare Taxes-Pay...	72.13
10948	09/07/2023	Pacific Western Bank	PE090123	Federal & Medicare Taxes-Pay...	66.32
10948	09/07/2023	Pacific Western Bank	PE090123	Federal & Medicare Taxes-Pay...	10.09
10948	09/07/2023	Pacific Western Bank	PE090123	Federal & Medicare Taxes-Pay...	133.04
10948	09/07/2023	Pacific Western Bank	PE090123	Federal & Medicare Taxes-Pay...	17.76
10948	09/07/2023	Pacific Western Bank	PE090123	Federal & Medicare Taxes-Pay...	67.77
10948	09/07/2023	Pacific Western Bank	PE090123	Federal & Medicare Taxes-Pay...	4.79
10948	09/07/2023	Pacific Western Bank	PE090123	Federal & Medicare Taxes-Pay...	12.85
10948	09/07/2023	Pacific Western Bank	PE090123	Federal & Medicare Taxes-Pay...	1.95
10948	09/07/2023	Pacific Western Bank	PE090123	Federal & Medicare Taxes-Pay...	1.11
10948	09/07/2023	Pacific Western Bank	PE090123	Federal & Medicare Taxes-Pay...	61.24
10948	09/07/2023	Pacific Western Bank	PE090123	Federal & Medicare Taxes-Pay...	29.40
10948	09/07/2023	Pacific Western Bank	PE090123	Federal & Medicare Taxes-Pay...	129.94
10948	09/07/2023	Pacific Western Bank	PE090123	Federal & Medicare Taxes-Pay...	29.93
10948	09/07/2023	Pacific Western Bank	PE090123	Federal & Medicare Taxes-Pay...	428.69
10949	09/07/2023	Pacific Western Bank	PE090123A	State Tax Withholdings-Pay E...	6,138.40
				Vendor 4105 - Pacific Western Bank	Total: 26,687.44

Vendor: 7223 - Pitney Bowes Global Financial Services LLC.

531320	09/19/2023	Pitney Bowes Global Financial ...	3106239473	July-September 23 Postage M...	428.05
				Vendor 7223 - Pitney Bowes Global Financial Services LLC. Total:	428.05

Vendor: 12474 - Project Partners

531321	09/19/2023	Project Partners	11334	Engineering Services July 23	4,440.00
531321	09/19/2023	Project Partners	11334	Engineering Services July 23	120.00
531321	09/19/2023	Project Partners	11334	Engineering Services July 23	2,640.00
531321	09/19/2023	Project Partners	11334	Engineering Services July 23	3,360.00
531321	09/19/2023	Project Partners	11334	Engineering Services July 23	2,400.00
531321	09/19/2023	Project Partners	11334	Engineering Services July 23	1,440.00
				Vendor 12474 - Project Partners Total:	14,400.00

Vendor: 12907 - Psomas

531322	09/19/2023	Psomas	199847	Engineering Services-Sewer M...	5,010.00
				Vendor 12907 - Psomas Total:	5,010.00

Vendor: 4090 - Public Employee Retirement System

10945	09/06/2023	Public Employee Retirement S...	17250407	GASB 68 Reports	1,050.00
10946	09/08/2023	Public Employee Retirement S...	September 23	Employee Health Insurance-S...	4,289.12
10946	09/08/2023	Public Employee Retirement S...	September 23	Employee Health Insurance-S...	2,648.86
10946	09/08/2023	Public Employee Retirement S...	September 23	Employee Health Insurance-S...	1,376.74
10946	09/08/2023	Public Employee Retirement S...	September 23	Employee Health Insurance-S...	3,646.69
10946	09/08/2023	Public Employee Retirement S...	September 23	Employee Health Insurance-S...	50.24
10946	09/08/2023	Public Employee Retirement S...	September 23	Employee Health Insurance-S...	4,282.15
10946	09/08/2023	Public Employee Retirement S...	September 23	Employee Health Insurance-S...	702.50
10946	09/08/2023	Public Employee Retirement S...	September 23	Employee Health Insurance-S...	4,517.23
10946	09/08/2023	Public Employee Retirement S...	September 23	Employee Health Insurance-S...	1,679.26
10946	09/08/2023	Public Employee Retirement S...	September 23	Employee Health Insurance-S...	2,639.47
10946	09/08/2023	Public Employee Retirement S...	September 23	Employee Health Insurance-S...	4,197.91
10946	09/08/2023	Public Employee Retirement S...	September 23	Employee Health Insurance-S...	1,405.00
10946	09/08/2023	Public Employee Retirement S...	September 23	Employee Health Insurance-S...	4,375.24
10946	09/08/2023	Public Employee Retirement S...	September 23	Employee Health Insurance-S...	1,435.13
10946	09/08/2023	Public Employee Retirement S...	September 23	Employee Health Insurance-S...	272.28
10946	09/08/2023	Public Employee Retirement S...	September 23	Employee Health Insurance-S...	865.05
10946	09/08/2023	Public Employee Retirement S...	September 23	Employee Health Insurance-S...	412.25
10946	09/08/2023	Public Employee Retirement S...	September 23	Employee Health Insurance-S...	2,752.23
10946	09/08/2023	Public Employee Retirement S...	September 23	Employee Health Insurance-S...	8,500.15
10953	09/13/2023	Public Employee Retirement S...	PE090123	Retirement Contributions-Pay...	12,501.14
10953	09/13/2023	Public Employee Retirement S...	PE090123	Retirement Contributions-Pay...	26.56
10953	09/13/2023	Public Employee Retirement S...	PE090123	Retirement Contributions-Pay...	831.93

Warrant Register

Payment Dates: 9/6/2023 - 9/19/2023

Payment Number	Payment Date	Vendor Name	Payable Number	Description (Item)	Amount	
10953	09/13/2023	Public Employee Retirement S...	PE090123	Retirement Contributions-Pay...	963.19	
10953	09/13/2023	Public Employee Retirement S...	PE090123	Retirement Contributions-Pay...	319.72	
10953	09/13/2023	Public Employee Retirement S...	PE090123	Retirement Contributions-Pay...	179.32	
10953	09/13/2023	Public Employee Retirement S...	PE090123	Retirement Contributions-Pay...	234.71	
10953	09/13/2023	Public Employee Retirement S...	PE090123	Retirement Contributions-Pay...	276.88	
10953	09/13/2023	Public Employee Retirement S...	PE090123	Retirement Contributions-Pay...	461.84	
10953	09/13/2023	Public Employee Retirement S...	PE090123	Retirement Contributions-Pay...	581.70	
10953	09/13/2023	Public Employee Retirement S...	PE090123	Retirement Contributions-Pay...	139.02	
10953	09/13/2023	Public Employee Retirement S...	PE090123	Retirement Contributions-Pay...	159.22	
10953	09/13/2023	Public Employee Retirement S...	PE090123	Retirement Contributions-Pay...	1,308.53	
10953	09/13/2023	Public Employee Retirement S...	PE090123	Retirement Contributions-Pay...	171.51	
10953	09/13/2023	Public Employee Retirement S...	PE090123	Retirement Contributions-Pay...	170.43	
10953	09/13/2023	Public Employee Retirement S...	PE090123	Retirement Contributions-Pay...	330.14	
10953	09/13/2023	Public Employee Retirement S...	PE090123	Retirement Contributions-Pay...	372.50	
10953	09/13/2023	Public Employee Retirement S...	PE090123	Retirement Contributions-Pay...	973.11	
10953	09/13/2023	Public Employee Retirement S...	PE090123	Retirement Contributions-Pay...	319.95	
10953	09/13/2023	Public Employee Retirement S...	PE090123	Retirement Contributions-Pay...	1,050.48	
10953	09/13/2023	Public Employee Retirement S...	PE090123	Retirement Contributions-Pay...	89.84	
10953	09/13/2023	Public Employee Retirement S...	PE090123	Retirement Contributions-Pay...	330.69	
10953	09/13/2023	Public Employee Retirement S...	PE090123	Retirement Contributions-Pay...	540.70	
10953	09/13/2023	Public Employee Retirement S...	PE090123	Retirement Contributions-Pay...	145.27	
10953	09/13/2023	Public Employee Retirement S...	PE090123	Retirement Contributions-Pay...	353.73	
10953	09/13/2023	Public Employee Retirement S...	PE090123	Retirement Contributions-Pay...	94.38	
10953	09/13/2023	Public Employee Retirement S...	PE090123	Retirement Contributions-Pay...	33.53	
10953	09/13/2023	Public Employee Retirement S...	PE090123	Retirement Contributions-Pay...	18.46	
10953	09/13/2023	Public Employee Retirement S...	PE090123	Retirement Contributions-Pay...	9.98	
10953	09/13/2023	Public Employee Retirement S...	PE090123	Retirement Contributions-Pay...	2.95	
10953	09/13/2023	Public Employee Retirement S...	PE090123	Retirement Contributions-Pay...	146.81	
10953	09/13/2023	Public Employee Retirement S...	PE090123	Retirement Contributions-Pay...	321.07	
10953	09/13/2023	Public Employee Retirement S...	PE090123	Retirement Contributions-Pay...	40.90	
10953	09/13/2023	Public Employee Retirement S...	PE090123	Retirement Contributions-Pay...	67.06	
10953	09/13/2023	Public Employee Retirement S...	PE090123	Retirement Contributions-Pay...	73.84	
10953	09/13/2023	Public Employee Retirement S...	PE090123	Retirement Contributions-Pay...	137.81	
10953	09/13/2023	Public Employee Retirement S...	PE090123	Retirement Contributions-Pay...	539.82	
10953	09/13/2023	Public Employee Retirement S...	PE090123	Retirement Contributions-Pay...	231.75	
10953	09/13/2023	Public Employee Retirement S...	PE090123	Retirement Contributions-Pay...	159.23	
10953	09/13/2023	Public Employee Retirement S...	PE090123	Retirement Contributions-Pay...	719.24	
10953	09/13/2023	Public Employee Retirement S...	PE090123	Retirement Contributions-Pay...	1,205.20	
10953	09/13/2023	Public Employee Retirement S...	PE090123	Retirement Contributions-Pay...	999.14	
				Vendor 4090 - Public Employee Retirement System	Total:	78,730.78
Vendor: 7135 - Quantum Consulting Inc.						
531323	09/19/2023	Quantum Consulting Inc.	LO23.005	Surveying Plan Check & Review	250.00	
				Vendor 7135 - Quantum Consulting Inc.	Total:	250.00
Vendor: 12844 - Qusai Smirat						
531262	09/06/2023	Qusai Smirat	7A2AB210-0004	Grad Sign Numbers-Sales Tax	-330.05	
531262	09/06/2023	Qusai Smirat	7A2AB210-0004	Grad Sign Numbers-4ft Marqu...	3,550.05	
				Vendor 12844 - Qusai Smirat Total:	3,220.00	
Vendor: 12173 - Race Communications						
531324	09/19/2023	Race Communications	RC980128	Internet Access CBCOG Septe...	1,530.00	
531324	09/19/2023	Race Communications	RC980128	Internet Access CBCOG Septe...	1,530.00	
				Vendor 12173 - Race Communications Total:	3,060.00	
Vendor: 12897 - Rady Sor						
531325	09/19/2023	Rady Sor	2004182.001	Refund-Tom Rico Center Depo...	200.00	
				Vendor 12897 - Rady Sor Total:	200.00	
Vendor: 7463 - Sakioka Wholesale Nursery, Inc.						
531326	09/19/2023	Sakioka Wholesale Nursery, In...	20092016	Largerstroemia, White Natchez	241.08	
531326	09/19/2023	Sakioka Wholesale Nursery, In...	20092016	Prunus C. Krauter Vesuvius	59.81	
				Vendor 7463 - Sakioka Wholesale Nursery, Inc.	Total:	300.89

Warrant Register

Payment Dates: 9/6/2023 - 9/19/2023

Payment Number	Payment Date	Vendor Name	Payable Number	Description (Item)	Amount
Vendor: 12898 - Sarah Perez					
531327	09/19/2023	Sarah Perez	2004180.001	Refund-Picnic Shelter Deposit...	75.00
Vendor 12898 - Sarah Perez Total:					75.00
Vendor: 7188 - Sharp Business Systems					
531328	09/19/2023	Sharp Business Systems	9004485827	BP70C55 Copier Usage 8/1/23...	301.47
Vendor 7188 - Sharp Business Systems					Total: 301.47
Vendor: 5050 - Southern California Edison Co.					
531263	09/13/2023	Southern California Edison Co.	700006214310-090123	Park	1,259.55
531263	09/13/2023	Southern California Edison Co.	700006214310-090123	Street Lights	32.42
531263	09/13/2023	Southern California Edison Co.	700006214310-090123	Traffic Signals	34.03
531263	09/13/2023	Southern California Edison Co.	700006910888-090623	Railroad Museum	366.50
531263	09/13/2023	Southern California Edison Co.	700007178650-090823	Narbonne Pedestrian Crosswa...	52.36
531263	09/13/2023	Southern California Edison Co.	700008444906-090623	Traffic Signals	615.21
531263	09/13/2023	Southern California Edison Co.	700016714053-090623	Lomita Park	2,734.03
531263	09/13/2023	Southern California Edison Co.	700016714053-090623	Western Ped. Crosswalk	15.86
531263	09/13/2023	Southern California Edison Co.	700016714053-090623	Appian Way	361.95
531263	09/13/2023	Southern California Edison Co.	700025877624-090123	Street Lights	599.68
531263	09/13/2023	Southern California Edison Co.	700025957042-090123	Street Lights	267.29
531263	09/13/2023	Southern California Edison Co.	700315793648-090123	Street Lights	190.82
531263	09/13/2023	Southern California Edison Co.	700492524416-090823	Hathaway Park	14.81
Vendor 5050 - Southern California Edison Co.					Total: 6,544.51
Vendor: 5040 - Southern California Gas Co.					
531329	09/19/2023	Southern California Gas Co.	07370472008-083123	Park Facilities	14.30
531329	09/19/2023	Southern California Gas Co.	07380495007-083123	City Hall Facility	391.40
Vendor 5040 - Southern California Gas Co.					Total: 405.70
Vendor: 1005 - Southern California News Group					
531330	09/19/2023	Southern California News Gro...	083123	Ads-Zone Text Amendment No..	385.35
531330	09/19/2023	Southern California News Gro...	083123	Ads-Zone Text Amendment No..	315.80
531330	09/19/2023	Southern California News Gro...	083123	Ads-Amendment to Lomita M...	299.01
531330	09/19/2023	Southern California News Gro...	083123	Ads-Propose Ordinance No. 8...	222.26
531330	09/19/2023	Southern California News Gro...	083123	Ads-Standby Power Generator	826.64
Vendor 1005 - Southern California News Group					Total: 2,049.06
Vendor: 12901 - Stephanie Estrada					
531331	09/19/2023	Stephanie Estrada	2004174.001	Refund-Museum Rentals Dep...	100.00
Vendor 12901 - Stephanie Estrada Total:					100.00
Vendor: 7386 - Taj Company					
531332	09/19/2023	Taj Company	73747	Gift Shop Supplies-Sales Tax	-19.17
531332	09/19/2023	Taj Company	73747	Train Bracelet	11.03
531332	09/19/2023	Taj Company	73747	Musical Pocket Watch	62.84
531332	09/19/2023	Taj Company	73747	Pocket Watch	149.60
Vendor 7386 - Taj Company					Total: 204.30
Vendor: 3956 - Ted's Plumbing Service Inc.					
531333	09/19/2023	Ted's Plumbing Service Inc.	38119	Remove & Install Granite Quar...	2,035.00
Vendor 3956 - Ted's Plumbing Service Inc.					Total: 2,035.00
Vendor: 12881 - The Sherwin-Williams Co					
531334	09/19/2023	The Sherwin-Williams Co	1417-0	Paints	76.33
531334	09/19/2023	The Sherwin-Williams Co	1784-3	Paint Recycling Fee	1.80
531334	09/19/2023	The Sherwin-Williams Co	1784-3	QT SW Plas Ratio Con	5.82
531334	09/19/2023	The Sherwin-Williams Co	1784-3	PI WB ALK UR	70.63
531334	09/19/2023	The Sherwin-Williams Co	1784-3	Paints	43.09
531334	09/19/2023	The Sherwin-Williams Co	1801-5	PI Procryl Primer	73.03
531334	09/19/2023	The Sherwin-Williams Co	1801-5	Paints	172.34
531334	09/19/2023	The Sherwin-Williams Co	1801-5	6.5 X 3/8 Woven Mini	8.71
531334	09/19/2023	The Sherwin-Williams Co	1801-5	9 Ultra Finish	9.41
531334	09/19/2023	The Sherwin-Williams Co	1801-5	Soft Woven 4X3/8"	18.79
531334	09/19/2023	The Sherwin-Williams Co	1801-5	Paint Recycle Fee	2.60
531334	09/19/2023	The Sherwin-Williams Co	1801-5	5 Gal Blue Pail	4.77

Warrant Register

Payment Dates: 9/6/2023 - 9/19/2023

Payment Number	Payment Date	Vendor Name	Payable Number	Description (Item)	Amount
531334	09/19/2023	The Sherwin-Williams Co	2040-9	Paints	63.73
Vendor 12881 - The Sherwin-Williams Co Total:					551.05
Vendor: 12654 - Theresa Yniguez					
531335	09/19/2023	Theresa Yniguez	2004179.001	Refund-Picnic Shelter Deposit...	40.00
Vendor 12654 - Theresa Yniguez Total:					40.00
Vendor: 6085 - Thompson Building Materials					
531336	09/19/2023	Thompson Building Materials	IV-154386	Baron Gag 14 X 26 Ply Bag	130.10
531336	09/19/2023	Thompson Building Materials	IV-154439	Sir Mix Pallet Deposit	40.80
531336	09/19/2023	Thompson Building Materials	IV-154439	Sir Mix 60 lb Concrete Mix	276.24
531336	09/19/2023	Thompson Building Materials	IV-154439	Sir Mix Pallet Return	-33.08
531336	09/19/2023	Thompson Building Materials	IV-154502	Baron Bag 15 X 26 Ply	65.05
531336	09/19/2023	Thompson Building Materials	IV-154502	Sir Mix Pallet Deposite	81.59
531336	09/19/2023	Thompson Building Materials	IV-154502	Sir Mix 60 lb Concrete Mix	552.48
531336	09/19/2023	Thompson Building Materials	IV-154984	Plaster Sand Scoop	173.80
531336	09/19/2023	Thompson Building Materials	IV-155056	Plaster Sand Scoop	304.15
531336	09/19/2023	Thompson Building Materials	IV-155061	Misc Base Skip	130.71
531336	09/19/2023	Thompson Building Materials	IV-155066	Misc. Base Skip	163.39
Vendor 6085 - Thompson Building Materials Total:					1,885.23
Vendor: 12228 - Toshiba					
531337	09/19/2023	Toshiba	34786066	Copier Lease August 23	745.76
Vendor 12228 - Toshiba Total:					745.76
Vendor: 4115 - United Way Campaign					
531338	09/19/2023	United Way Campaign	091123	Employee Contribution/Janua...	1,008.00
Vendor 4115 - United Way Campaign Total:					1,008.00
Vendor: 6878 - Urban Feet Inc.					
531339	09/19/2023	Urban Feet Inc.	LOM 090123	Work Boots-P. Nunez	200.00
531339	09/19/2023	Urban Feet Inc.	LOM 090123	Work Boots-J. Garcia	200.00
531339	09/19/2023	Urban Feet Inc.	LOM 090123	Work Boots-G. Maldonado	186.14
531339	09/19/2023	Urban Feet Inc.	LOM 090123	Work Boots-E. Spindola	195.45
531339	09/19/2023	Urban Feet Inc.	LOM 090123	Work Boots-W. Ibarra	181.49
531339	09/19/2023	Urban Feet Inc.	LOM 090123	Work Boots-D. Huerta	195.45
Vendor 6878 - Urban Feet Inc. Total:					1,158.53
Vendor: 4130 - Vision Service Plan (CA)					
531340	09/19/2023	Vision Service Plan (CA)	818780990	Employee Vision Insurance-Se...	617.98
531340	09/19/2023	Vision Service Plan (CA)	818780990	Employee Vision Insurance-Se...	42.46
531340	09/19/2023	Vision Service Plan (CA)	818780990	Employee Vision Insurance-Se...	33.27
531340	09/19/2023	Vision Service Plan (CA)	818780990	Employee Vision Insurance-Se...	42.41
531340	09/19/2023	Vision Service Plan (CA)	818780990	Employee Vision Insurance-Se...	45.90
531340	09/19/2023	Vision Service Plan (CA)	818780990	Employee Vision Insurance-Se...	19.61
531340	09/19/2023	Vision Service Plan (CA)	818780990	Employee Vision Insurance-Se...	27.55
531340	09/19/2023	Vision Service Plan (CA)	818780990	Employee Vision Insurance-Se...	45.90
531340	09/19/2023	Vision Service Plan (CA)	818780990	Employee Vision Insurance-Se...	43.61
531340	09/19/2023	Vision Service Plan (CA)	818780990	Employee Vision Insurance-Se...	78.03
531340	09/19/2023	Vision Service Plan (CA)	818780990	Employee Vision Insurance-Se...	45.92
531340	09/19/2023	Vision Service Plan (CA)	818780990	Employee Vision Insurance-Se...	3.44
531340	09/19/2023	Vision Service Plan (CA)	818780990	Employee Vision Insurance-Se...	2.30
531340	09/19/2023	Vision Service Plan (CA)	818780990	Employee Vision Insurance-Se...	3.44
531340	09/19/2023	Vision Service Plan (CA)	818780990	Employee Vision Insurance-Se...	9.18
531340	09/19/2023	Vision Service Plan (CA)	818780990	Employee Vision Insurance-Se...	37.09
531340	09/19/2023	Vision Service Plan (CA)	818780990	Employee Vision Insurance-Se...	129.75
531341	09/19/2023	Vision Service Plan (CA)	818780939	Cobra-September 23	10.33
531341	09/19/2023	Vision Service Plan (CA)	818780939	Cobra-September 23	12.62
Vendor 4130 - Vision Service Plan (CA) Total:					1,250.79
Vendor: 7373 - Wells Fargo Vendor Financial Services					
531342	09/19/2023	Wells Fargo Vendor Financial ...	5026491959	MX-C304W Printer Property T...	91.77
531342	09/19/2023	Wells Fargo Vendor Financial ...	5026499797	MX-5070V Copier Property Tax	37.60
Vendor 7373 - Wells Fargo Vendor Financial Services Total:					129.37

Warrant Register

Payment Dates: 9/6/2023 - 9/19/2023

Payment Number	Payment Date	Vendor Name	Payable Number	Description (Item)	Amount
Vendor: 3044 - West Basin Municipal Water District					
10950	09/08/2023	West Basin Municipal Water D...	WB6158	July 23	294,759.00
				Vendor 3044 - West Basin Municipal Water District	Total: 294,759.00
Vendor: 7282 - Williams Data Management					
531343	09/19/2023	Williams Data Management	0626438	File Storage August 23	163.23
				Vendor 7282 - Williams Data Management	Total: 163.23
Vendor: 12679 - Yushi Kanawaza					
531344	09/19/2023	Yushi Kanawaza	2004191.001	Refund-Gymnasium Deposit- ...	100.00
				Vendor 12679 - Yushi Kanawaza Total:	100.00
Grand Total:					728,190.77

Report Summary

Fund Summary

Fund	Payment Amount
100 - General Fund	200,361.69
204 - General Plan Update	114,977.50
205 - State Gas Tax	7,611.62
209 - Measure M	225.00
215 - Community Development Block Grant	4,960.00
220 - Proposition A Local Return	955.04
245 - Landscape Maintenance District #1	167.45
255 - Park Athletic	183.19
257 - Park Grant	120.00
311 - Street Improvement	10,867.50
510 - Water Operations	334,861.95
520 - Water Capital	46,142.74
612 - Sewer Replacement	5,010.00
720 - Railroad Museum Foundation	1,747.09
Grand Total:	728,190.77

Account Summary

Account Number	Account Name	Payment Amount
100-000-2107.000	Accrued Expenses	-449.00
100-000-2210.000	Sales Tax Withholding	-330.05
100-000-2285.000	Employee Association D...	600.00
100-000-2508.000	Garnishment	230.76
100-000-2510.000	PERS	12,501.14
100-000-2515.000	Health Insurance	4,289.12
100-000-2525.000	United Way	1,008.00
100-000-2540.000	Dental Insurance	2,922.53
100-000-2545.000	Vision Insurance	617.98
100-000-2550.000	Federal Withholding	18,257.19
100-000-2555.000	State Withholding	6,138.40
100-000-2560.000	Deferred Compensation	11,840.84
100-000-4414.000	Business License Fee	53.75
100-000-4455.000	Parks and Recreation Fe...	145.00
100-000-4510.000	Park Rentals	935.00
100-110-5207.000	Medicare	9.48
100-110-5217.000	PERS Tier 3 (2%@62)	26.56
100-110-5430.000	Conferences and Meetin...	501.70
100-110-5755.000	Special Department Supp..	116.48
100-120-5305.000	Legal Services	24,401.41
100-125-5205.000	Health Insurance	3,150.71
100-125-5207.000	Medicare	254.91
100-125-5215.000	PERS Tier 1 (2.5%@55)	831.93
100-125-5216.000	PERS Tier 2 (2%@60)	963.19
100-125-5217.000	PERS Tier 3 (2%@62)	319.72
100-125-5345.000	Contractual Services	3,333.33
100-125-5430.000	Conferences and Meetin...	40.00
100-125-5755.000	Special Department Supp..	12.99
100-130-5205.000	Health Insurance	1,814.66
100-130-5207.000	Medicare	101.55
100-130-5215.000	PERS Tier 1 (2.5%@55)	179.32
100-130-5216.000	PERS Tier 2 (2%@60)	234.71
100-130-5217.000	PERS Tier 3 (2%@62)	276.88
100-130-5410.000	Advertising	1,232.42
100-130-5505.000	Office Supplies and Expe...	253.27
100-130-5710.000	Equipment Maintenance	428.05
100-130-5755.000	Special Department Supp..	19.99
100-210-5205.000	Health Insurance	3,903.26
100-210-5207.000	Medicare	145.29

Account Summary

Account Number	Account Name	Payment Amount
100-210-5215.000	PERS Tier 1 (2.5%@55)	461.84
100-210-5216.000	PERS Tier 2 (2%@60)	581.70
100-210-5217.000	PERS Tier 3 (2%@62)	139.02
100-210-5310.000	Auditors	2,000.00
100-210-5340.000	Professional Services	3,364.99
100-210-5345.000	Contractual Services	1,763.36
100-210-5435.000	Training and Education	70.00
100-230-5205.000	Health Insurance	260.86
100-230-5206.000	Health Insurance Retirees	4,282.15
100-230-5207.000	Medicare	95.39
100-230-5217.000	PERS Tier 3 (2%@62)	159.22
100-230-5755.000	Special Department Supp..	303.46
100-335-5205.000	Health Insurance	702.50
100-335-5207.000	Medicare	55.48
100-335-5345.000	Contractual Services	4,625.28
100-335-5710.000	Equipment Maintenance	4,293.37
100-410-5205.000	Health Insurance	5,078.54
100-410-5207.000	Medicare	231.56
100-410-5217.000	PERS Tier 3 (2%@62)	1,308.53
100-410-5315.000	Engineers	250.00
100-410-5345.000	Contractual Services	253.23
100-440-5345.000	Contractual Services	9,317.29
100-440-5415.000	Communications	522.70
100-440-5525.000	Equipment Under \$5k	1,654.71
100-440-5605.000	Rents and Leases	1,176.60
100-605-5205.000	Health Insurance	1,956.21
100-605-5207.000	Medicare	104.68
100-605-5216.000	PERS Tier 2 (2%@60)	171.51
100-605-5217.000	PERS Tier 3 (2%@62)	170.43
100-605-5345.000	Contractual Services	4,440.00
100-605-5420.000	Mileage Reimbursement	19.98
100-610-5205.000	Health Insurance	2,997.58
100-610-5207.000	Medicare	115.92
100-610-5216.000	PERS Tier 2 (2%@60)	330.14
100-610-5217.000	PERS Tier 3 (2%@62)	372.50
100-710-5205.000	Health Insurance	4,602.67
100-710-5207.000	Medicare	110.58
100-710-5215.000	PERS Tier 1 (2.5%@55)	973.11
100-710-5217.000	PERS Tier 3 (2%@62)	319.95
100-710-5340.000	Professional Services	100.00
100-710-5405.000	Utilities	391.40
100-710-5425.000	Dues and Memberships	70.00
100-710-5430.000	Conferences and Meetin...	120.00
100-710-5505.000	Office Supplies and Expe...	41.56
100-710-5515.000	Uniform Expense	200.00
100-710-5705.000	General Maintenance	9,824.24
100-710-5710.000	Equipment Maintenance	203.50
100-710-5720.000	Fuel	125.13
100-730-5205.000	Health Insurance	1,783.48
100-730-5207.000	Medicare	138.45
100-730-5215.000	PERS Tier 1 (2.5%@55)	1,050.48
100-730-5217.000	PERS Tier 3 (2%@62)	89.84
100-730-5345.000	Contractual Services	3,251.50
100-730-5410.000	Advertising	408.57
100-730-5505.000	Office Supplies and Expe...	348.34
100-730-5515.000	Uniform Expense	59.14
100-730-5755.000	Special Department Supp..	989.11
100-735-5754.339	Teen Program	254.71

Account Summary

Account Number	Account Name	Payment Amount
100-735-5755.000	Special Department Supp..	3,870.06
100-740-5205.000	Health Insurance	4,926.25
100-740-5207.000	Medicare	143.13
100-740-5215.000	PERS Tier 1 (2.5%@55)	330.69
100-740-5216.000	PERS Tier 2 (2%@60)	540.70
100-740-5217.000	PERS Tier 3 (2%@62)	145.27
100-740-5405.000	Utilities	4,022.69
100-740-5505.000	Office Supplies and Expe...	87.41
100-740-5510.000	Small Tools	59.45
100-740-5515.000	Uniform Expense	763.08
100-740-5705.000	General Maintenance	2,674.73
100-740-5710.000	Equipment Maintenance	483.56
100-740-5720.000	Fuel	1,485.15
100-750-5207.000	Medicare	17.76
100-750-5405.000	Utilities	366.50
100-750-5415.000	Communications	26.20
100-750-5755.000	Special Department Supp..	20.10
204-410-5345.000	Contractual Services	114,977.50
205-610-5205.000	Health Insurance	1,817.59
205-610-5207.000	Medicare	72.56
205-610-5217.000	PERS Tier 3 (2%@62)	353.73
205-610-5405.000	Utilities	2,072.44
205-610-5435.000	Training and Education	450.86
205-610-5705.000	General Maintenance	59.42
205-610-5710.000	Equipment Maintenance	130.37
205-610-5720.000	Fuel	2,009.30
205-620-5705.000	General Maintenance	420.35
205-810-5806.374	Narbonne South Pipe Re...	225.00
209-810-5806.374	Narbonne South Pipe Re...	225.00
215-540-5340.000	Professional Services	1,550.00
215-550-5340.000	Professional Services	3,410.00
220-340-5205.000	Health Insurance	312.49
220-340-5207.000	Medicare	12.85
220-340-5215.000	PERS Tier 1 (2.5%@55)	94.38
220-340-5216.000	PERS Tier 2 (2%@60)	33.53
220-340-5217.000	PERS Tier 3 (2%@62)	18.46
220-340-5345.000	Contractual Services	483.33
245-720-5405.000	Utilities	167.45
255-760-5205.000	Health Insurance	22.58
255-760-5207.000	Medicare	1.95
255-760-5217.000	PERS Tier 3 (2%@62)	9.98
255-760-5506.000	Sport Supplies	52.35
255-760-5735.000	Miscellaneous Expense	96.33
257-830-5345.379	Contractual Services	120.00
311-810-5806.367	Street Reconstruction-Z...	2,640.00
311-810-5806.368	Street Reconstruction - ...	8,227.50
510-110-5207.000	Medicare	1.11
510-110-5217.000	PERS Tier 3 (2%@62)	2.95
510-120-5305.000	Legal Services	946.59
510-125-5205.000	Health Insurance	888.83
510-125-5207.000	Medicare	61.24
510-125-5215.000	PERS Tier 1 (2.5%@55)	146.81
510-125-5216.000	PERS Tier 2 (2%@60)	321.07
510-130-5205.000	Health Insurance	531.78
510-130-5207.000	Medicare	29.40
510-130-5215.000	PERS Tier 1 (2.5%@55)	40.90
510-130-5216.000	PERS Tier 2 (2%@60)	67.06
510-130-5217.000	PERS Tier 3 (2%@62)	73.84

Account Summary

Account Number	Account Name	Payment Amount
510-220-5205.000	Health Insurance	3,004.65
510-220-5207.000	Medicare	129.94
510-220-5215.000	PERS Tier 1 (2.5%@55)	137.81
510-220-5216.000	PERS Tier 2 (2%@60)	539.82
510-220-5217.000	PERS Tier 3 (2%@62)	231.75
510-220-5310.000	Auditors	2,000.00
510-220-5345.000	Contractual Services	237.79
510-220-5505.000	Office Supplies and Expe...	484.99
510-230-5205.000	Health Insurance	210.62
510-230-5207.000	Medicare	29.93
510-230-5217.000	PERS Tier 3 (2%@62)	159.23
510-440-5345.000	Contractual Services	6,521.57
510-630-5205.000	Health Insurance	10,375.92
510-630-5207.000	Medicare	428.69
510-630-5215.000	PERS Tier 1 (2.5%@55)	719.24
510-630-5216.000	PERS Tier 2 (2%@60)	1,205.20
510-630-5217.000	PERS Tier 3 (2%@62)	999.14
510-630-5405.000	Utilities	361.95
510-630-5411.000	Customer Notifications	231.63
510-630-5415.000	Communications	50.90
510-630-5440.000	Water Purchases - MWD	294,759.00
510-630-5505.000	Office Supplies and Expe...	190.33
510-630-5510.000	Small Tools	96.43
510-630-5515.000	Uniform Expense	488.73
510-630-5705.000	General Maintenance	6,806.44
510-630-5709.000	Equipment Maintenance...	88.19
510-630-5710.000	Equipment Maintenance	152.29
510-630-5720.000	Fuel	887.14
510-630-5755.000	Special Department Supp..	221.05
520-840-5820.134	Emergency Generator	20,420.33
520-840-5821.239	Appian Way Roof	3,360.00
520-840-5821.357	246th-247th-247th Pl - ...	2,400.00
520-840-5821.365	CWPF Upgrades Project	6,886.41
520-840-5821.372	Annual Aged Pipeline R...	1,440.00
520-840-5821.374	Narbonne South Pipe Re...	11,636.00
612-910-5345.000	Contractual Services	5,010.00
720-000-2210.000	Sales Tax Withholding	-19.17
720-750-5513.000	Museum Gift Shop Expe...	1,177.57
720-990-5998.000	Transfer to Railroad Mus...	588.69
	Grand Total:	728,190.77

Project Account Summary

Project Account Key	Payment Amount
None	670,610.53
205-Narbonne South Pipe Replacement	225.00
209-Narbonne South Pipe Replacement	225.00
246th St., 247th Pl., 247th St.-Western	2,400.00
311 Street Reconstruction	2,640.00
311-Street Reconstruction-Zone G	8,227.50
520.134	20,420.33
520-Narbonne South Pipe Replacement	11,636.00
Annual Aged Pipeline R&R	1,440.00
Appian Way Roof	3,360.00
Cypress Water Production	6,886.41
Stephenson Mainenance Project	120.00
Grand Total:	728,190.77



CITY OF LOMITA CITY COUNCIL REPORT

TO: City Council **Item No. 7c**
FROM: Ryan Smoot, City Manager
PREPARED BY: Susan Kamada, Administrative Services Director
MEETING DATE: September 19, 2023
SUBJECT: Monthly Report for the Administrative Services Department

RECOMMENDATION

Receive and file the monthly report for the Administrative Services Department.

BACKGROUND

Accounting Activities:

- Staff submitted the unaudited Financials for Lomita Manor to HUD
- Staff submitted annual Forms to LACMTA
- Staff participated in Interview Panel for City of Signal Hill and City of Compton
- Staff participated in GFOA's "Why it's Time to Rethink Reserves" Webinar
- Staff participated in MissionSquare's "Secure 2.0 – 2023 Governmental Plan Implementation" Webinar
- Staff participated in GFOA's "Fostering an Engaged Public Finance Workforce" Webinar

Department activity levels for the month of August 2023 are provided below:

<i>Journal Entries/Adjustments</i>	6
<i>Payroll Updates/Maintenance Changes</i>	90 / 1 New Hires
<i>Purchase Orders Issued</i>	6
<i>Purchase Orders Paid</i>	13
<i>Invoices Processed for Payment</i>	238
<i>Checks Processed (Demands & Manual)</i>	153
<i>Payroll Checks Processed</i>	182
<i>Business Licenses Issued (New / Renewals)</i>	35/111
<i>Water Utility Bills Mailed/Late Notices Issued</i>	<i>Water Late Notices Issued 599</i>
<i>Service Orders Issued (for Water Accounts)</i>	115

OPTIONS:

None. Information only. Receive and file.

FISCAL IMPACT

None. Information only. Receive and file.

Reviewed by:



Gary Y. Sugano
Assistant City Manager

Approved by:



Ryan Smoot
City Manager

Prepared by:



Susan Kamada
Administrative Services Director



CITY OF LOMITA CITY COUNCIL REPORT

TO: City Council **Item No. 7d**

FROM: Ryan Smoot, City Manager

PREPARED BY: Gary Y. Sugano, Assistant City Manager

MEETING DATE: September 19, 2023

SUBJECT: Monthly Report for the City Manager's Department

RECOMMENDATION

Receive and file the monthly report for the City Manager's Department.

BACKGROUND

Information Technology

Numa Networks is currently on-site one day per week to provide as-needed IT support. During the month of August, Numa Networks assisted with a total of 91 trouble tickets.

Human Resources/Risk Management

The City currently has two (2) recruitments open; Payroll Accountant in the Administrative Services Department, and Principal Engineer in the Public Works Department. The most qualified applicants will be invited to participate in a panel interview.

Sean Ritchie accepted the position of Recreation Supervisor in the Recreation and Facilities Division. Sean began work on Monday, August 28, 2023. Jennifer Howell accepted the position of Associate Engineer in the Public Works Department and is scheduled to start on October 16, 2023. John Campos was promoted from Part-time Parking Enforcement Officer to Fulltime Parking Enforcement Supervisor in the Assistant City Manager's Department. John will begin his new position on Monday, September 18, 2023.

Human Resources staff attended the JPIA Risk Managers conference in Carlsbad from August 30, 2023 – September 1, 2023. HR staff also attended the JPIA Workers Comp Symposium on September 6, 2023, in La Palma.

Emergency Management

The city was awarded a FEMA Hazard Mitigation Assistance Grant in the amount of \$1,124,884.50 for the 247th Street Area Water Main Replacement Project. Quarterly report #8 was submitted on 7/10/23 indicating that design is currently underway but obtaining the necessary permits from the City of Los Angeles took much longer than expected, significantly putting the project behind schedule. The city was granted a one-year extension to complete the project due to this delay. Staff is gathering information and drafting a formal request to CalOES/FEMA for a budget increase, potential changes to the scope of work, and/or another time extension related to this project. The City of Los Angeles' permit fees are much higher than originally estimated, labor and material costs have increased, and potholing revealed oily soil and lead requiring staff to consider detouring the original layout. Staff met with CalOES on August 28 to review these concerns and determine next steps. Testing results came back indicating the oil and lead contaminations not to be significant and not requiring changes to the original scope of work. At this time, staff will be submitting another formal request for a time extension through May 2025 to complete the project.

On June 7, 2023, staff received notification that FEMA approved the city's grant application to update the Local Hazard Mitigation Plan (LHMP) and awarded Lomita \$72,680 for the project costs and \$3,622 for grant management costs. Staff had the official "kick-off" meeting with CalOES on June 12 and is working on releasing an RFP in the near future.

The American Red Cross facility use agreement was approved by the City Council on August 15. Staff will be monitoring for grant opportunities to help make improvements to the newly designated disaster shelter, the Tom Rico Center and Marc Fosnaugh gym. In addition, staff met with the American Red Cross Executive Director for the South Bay Chapter on August 23. Staff will be collaborating with the American Red Cross to host a smoke detector alarm installation and blood drive events in Lomita in the near future.

Lomita Manor

The Lomita Manor property management company, HumanGood, continues providing several activities to residents. These activities include Exercise/Chair class, Coloring class, and Seasonal Holiday activities such as the St Patrick's Celebration, Easter Egg Craft and Fourth of July BBQ. Additional activities that have been added include Bingo, Walking Group, Art Class and Bi-Monthly Celebrations of residents' birthdays with cake. The property management team will continue to explore other activities for the residents at Lomita Manor. In addition to these activities, Lomita Manor's Recreation room is open to the residents.

Community Development Block Grant Programs

On February 7, 2023, the Community Development Advisory Board (CDAB) approved the CDBG roster (budget) for FY 23-24 in the amount of \$140,077 to fund Residential Rehabilitation, Lifeline and the Job Creation and Business Incentive Loan Programs. Ongoing updates regarding the CDBG programs will be mentioned below.

Residential Rehabilitation: For Fiscal Year 2023-24, a total of two projects are scheduled to be completed.

Lifeline: The Lifeline program provides emergency response service for a total of 19 subscribers currently enrolled. The program is accepting applications from Lomita residents who are at least 55 years old or disabled.

City Clerk’s Office

- Continued work on agenda management and meeting video streaming project implementation
- Staff completed required sexual harassment prevention training
- Staff participated in meetings for phone system upgrade

Administrative staff continues to provide customer service and support related to processing water payments, parking tickets, Dial-a-Ride, planning counter appointments and business licenses.

City Clerk activity for the month of August

Council Meeting Agenda & Minutes Prepared	1/1
Council Resolutions Adopted & Processed	2
Housing Authority Agenda & Minutes Prepared	0/0
Contracts/Agreements Processed	2
Ordinances Adopted & Published	0
Certificates Prepared	56
Public Records Requests Processed	17
Dial-a-Ride New Cards Issued	5
Dial-a-Ride Payments Processed	32
Dial-a-Ride Assistance-Phone/Counter	22
Administrative Parking Appeals Reviewed & Processed	31
Parking Citations Issued & Processed	1037
Parking Citations Assistance – Phone/Counter	83
Planning Commission Meeting Agenda & Minutes Prepared	1/1
Planning Commission Resolutions Processed	2
Public Safety & Traffic Commission Agenda & Minutes Prepared	0/0
Technical Traffic Advisory Committee Agenda & Minutes Prepared	0/0
Scanned & Indexed Documents	15
Water Billing Payments and Assistance- Phone/Counter	168

OPTIONS:

None. Information only. Receive and file.

FISCAL IMPACT

None. Information only. Receive and file.

ATTACHMENTS

None.

Prepared by:

Gary Sugano

Gary Sugano
Assistant City Manager

Approved by:

Ryan Smoot

Ryan Smoot
City Manager



CITY OF LOMITA CITY COUNCIL REPORT

TO: City Council **Item No. 7e**

FROM: Ryan Smoot, City Manager

PREPARED BY: Brianna Rindge, Community & Economic Development Director

MEETING DATE: September 19, 2023

SUBJECT: Monthly Report for the Community & Economic Development Department

RECOMMENDATION

Receive and file the Community & Economic Development Department monthly report.

DISCUSSION

- Several ordinance discussions will be on Planning Commission and City Council agendas as triggered by applicant requests, observed trends, post-COVID interest, the certified Housing Element, and other State mandates. The draft 2023 upcoming items schedule is as follows.

<i>Topic</i>	<i>Council Discussion</i>	<i>Planning Commission Hearing</i>	<i>City Council Hearings</i>
Building Code update	Adopted; in effect Jan. 1, 2023		
24000 Crenshaw Specific Plan update	Adopted; in effect Feb. 16, 2023		
Low-Barrier Navigation Centers	Adopted; in effect April 20, 2023		
Supportive Housing update	Adopted; in effect April 20, 2023		
Transitional Housing update	Adopted; in effect April 20, 2023		
Employee Housing	Adopted; in effect April 20, 2023		
Reasonable Accommodation update	Adopted; in effect April 20, 2023		
Covered Parking	Adopted; in effect April 20, 2023		
Emergency Shelter Parking	Adopted; in effect April 20, 2023		
Substandard Living Conditions	Adopted; in effect April 20, 2023		
Unused Zoning Districts clean-up	Adopted; in effect April 20, 2023		
Designated Parking, Signage	Adopted; in effect May 18, 2023		
Massage clean-up	Adopted; in effect June 1, 2023		

Outdoor Dining update	Adopted; in effect June 15, 2023		
Lot Design clean-up for consistency with adopted Ord. No. 839	Adopted; in effect June 15, 2023		
Chickens update	Adopted; in effect June 15, 2023		
ADU update	Adopted; in effect July 20, 2023		
Murals	Adopted; in effect October 5, 2023		
Affordable Housing Incentives for 4 Residential Units or Less within Downtown-Commercial District within Mixed-Use Overlay District	n/a	July 2023; Aug 2023	Sep. 2023

- Staff met with multiple property owners and developers and completed review of residential and commercial building permits, solar, wireless facilities, business licenses, and Residential Property Reports.

Code Enforcement

The addition of a part-time contract Code Enforcement officer through contract in February to augment the full-time officer’s efforts yielded a significant increase in citywide code compliance, including enforcement of illegal dumping and graffiti as shown in the chart.

Code Enforcement Activity FY 22-23

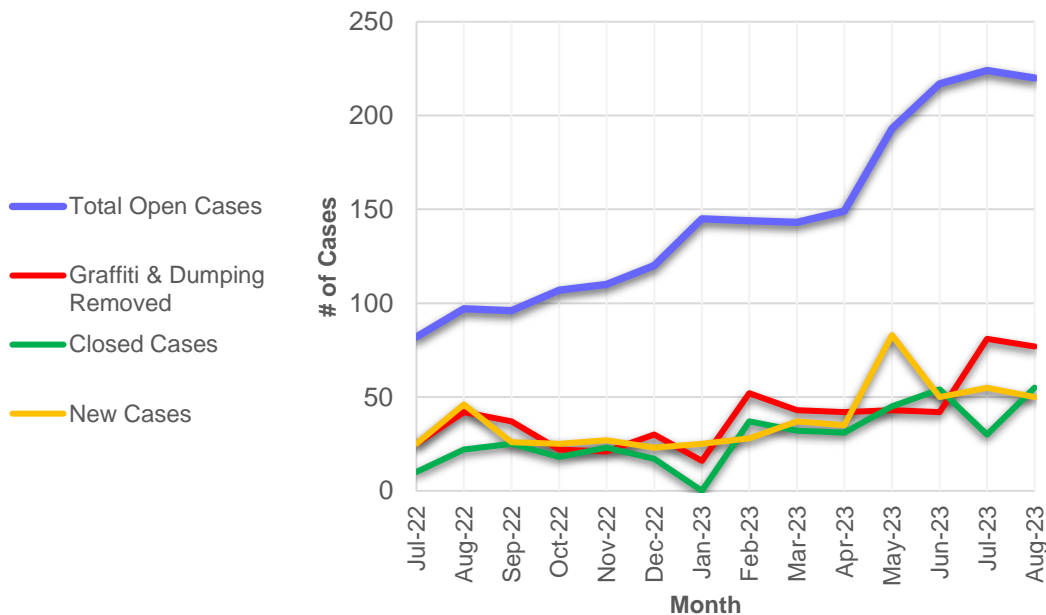

OPTIONS

None. Information only. Receive and file.

Reviewed by:

Gary Sugano

Gary Y. Sugano
Assistant City Manager

Approved by:

Ryan Smoot

Ryan Smoot
City Manager

Prepared by:

Brianna Rindge

Brianna Rindge
Community & Economic Development Director



CITY OF LOMITA CITY COUNCIL REPORT

TO: City Council **Item No. 7f**

FROM: Ryan Smoot, City Manager

PREPARED BY: Michael M. Sansbury, Recreation & Facilities Manager

MEETING DATE: September 19, 2023

SUBJECT: Monthly Report for the Recreation and Facilities Division

RECOMMENDATION

Receive and file the monthly report for the Recreation and Facilities Division.

RECREATION SERVICES

- Non-Resident sign-ups for Lomita Park Youth Sports began on September 1st.
- Signups for Fall classes begin August 15th at 9:00am in person and online.
- The Lomita Railroad Foundation hosted its 2 Speaker Series in the month of August at the Lomita Railroad Museum; with another scheduled for September 8th at 6pm.
- The Lomita Railroad Museum is gearing up for Family Fun Day on September 23rd at 11:00am on the Irene Lewis Field.
- Staff is gearing up for the end of the year special events, such as Halloween, Veteran's Day, Tree lighting, and assisting with State of the City and Santa event at the museum.
- The Lomita Railroad staff is working to change out museum artifacts, for guests to enjoy seasonally.
- The Recreation Department welcomes its newest full-time employee on Monday, Aug 28, 2023.

YOUTH SPORTS

- Youth Flag Football and Volleyball will begin the week of September 18th.
 - Currently we have a total of (57) participants enrolled for Flag Football and (62) for Volleyball.

ADULT SPORTS

- Men's Basketball leagues are in progress and will continue until October 4th. We have (10) total teams playing in (2) leagues.

PROGRAM REGISTRATIONS

- Fall registration started for Lomita residents on August 15 and non-residents will begin on September 1st.

PROJECTS

- Football and Volleyball training of part time staff.
- Fall program scheduling, planning, and purchasing.

MAINTENANCE AND FACILITIES

- The elevator at City Hall was serviced, and tests were performed as required by the State of California Department of Industrial Relations Division of Occupational Safety and Health.
- Installed two 50amp EV charger outlets and a 240volt outlet for the welder at the City Yard.
- Repaired and serviced numerous key cylinders at Lomita Park.
- Staff has begun cleaning up and reorganizing the Historic Room at City Hall.
- Rekeyed all cabinets in the kitchen at the Tom Rico center.
- Staff steam cleaned the carpet at 1st floor hallways at City Hall.
- Troubleshooting the interior wall behind the stage in the Marc Fosnaugh Gymnasium to repair and paint.

OPTIONS:

None. Information only. Receive and file.

FISCAL IMPACT

None. Information only. Receive and file.

Reviewed by:

Gary Sugano

Gary Y. Sugano
Assistant City Manager

Approved by:

Ryan Smoot

Ryan Smoot
City Manager

Prepared by:

Michael M. Sansbury

Michael M. Sansbury
Recreation & Facilities Manager

Prepared by:

Emma Kelley

Emma Kelley
Recreation Manager



CITY OF LOMITA CITY COUNCIL REPORT

TO: City Council **Item No. 7g**

FROM: Ryan Smoot, City Manager

PREPARED BY: Carla Dillon, P.E., Director of Public Works

MEETING DATE: September 19, 2023

SUBJECT: Monthly Report for the Public Works Department

RECOMMENDATION:

Receive and file the monthly report for the Public Works Department.

BACKGROUND:

Water Division Updates

Cypress Water Production Facility (CWPF) and Distribution System Update

Well No. 5 remains offline due to the detection of benzene and the construction project to upgrade the CWPF. The State's Division of Drinking Water (DDW) and the Los Angeles Regional Water Quality Control Board (RWQCB) have been investigating possible sources of benzene, and information is available at <https://www.lomitawater.com/news/>.

In August 2023, the City pumped 0.0 acre-feet of groundwater from Well No. 5. All drinking water was supplied with imported water from West Basin MWD. West Basin MWD invoiced the City after the monthly report was filed for the months of July and August; the City imported 176.4 acre-feet from and 168.7 acre-feet, respectively, from West Basin MWD. The Monthly water reports can be found at www.lomitawater.com/oversight/water-quality-reports/.

To protect the water system, all backflow devices within the service area are required to be tested once per year. In Lomita's water system there are approximately 160 backflow devices, and in August letters and backflow test forms were sent to the customers requiring the devices be tested and forms submitted by September 18. The City has received 45% of the test results. If testing is not completed, a second notice will be sent with a late fee applied to the account. Following the third notification, water shutoff of those accounts/connections will be necessary to protect the water system.

The City has been offering monthly tours of the Cypress Water Production Facility. Three tours were conducted in August, including one for the Lomita Chamber of Commerce. A total of twelve community members toured the facility. Residents who are interested in touring the facility may sign up for a tour at <https://www.lomitawater.com/water-tours/>.

Water Division Performance Measures:

Main Breaks/Leak Repairs	0
Service Connection Breaks/Leaks	3
Water Outages	0
Water Service Requests	90
USA Dig-Alert Tickets	80
Dead-end Fire Hydrant Flushing	15
Meter Maintenance	10
Inspection of Water Facilities	Daily
Water Quality Complaints	0

Engineering/PW Administration Division Updates

CIP Update

Cypress Water Production Facility (CWPF) Upgrade Project

The City’s contractor RC Foster, with the oversight of the contract manager, AKM Consulting Engineers, is progressing on construction. Hazen and Sawyer continue to provide support for the permitting with the Division of Drinking Water (DDW). During this period, RC Foster worked on pipe labelling, security camera system, and the data control system. In addition, the City’s IT provider worked on ensuring internet service.

Progress	As of August 31, 2023
Percent Project completion	99%
Overall Project, invoiced/approved	\$4,334,619
Overall Project budget (approved contracts)	\$4,835,131

The City shares project updates on <https://www.lomitawater.com/> as new information is available. In addition, a short video describing the GAC project and treatment process is available here: <https://www.lomitawater.com/infrastructure/granular-activated-carbon/>.

Street Reconstruction – Zone G

This project consists of overlaying and reconstructing certain streets in Zones G (just north and south of Lomita Boulevard and east of Eshelman Avenue), as detailed in the Pavement Management Program (PMP). This project includes significant repairs and resurfacing of streets where slurry seal would not be sufficient to extend the life of the street.

The design of the project was awarded to David Evans and Associates (DEA) in July 2022, and the design is scheduled to be completed in 2023. Construction is programmed for Spring-Summer 2024. Extensive field investigation and sampling have taken place to evaluate the road condition on the 17 streets included in this project, and the City has received related technical reports. In addition, DEA has identified and provided preliminary cost estimates for curb ramps that require upgrades in the project zone. DEA has completed 60% of detailed design drawings, and engineering staff has reviewed and approved. DEA is now working on completing the 100% drawings.

Progress	As of August 31, 2023
Percent Design Project completion	60% (of design)
Overall Project, invoiced/approved	\$123,410.26
Overall Project budget including construction.	\$1,200,000.00

247th Street Area Watermain Project

This project consists of abandoning a watermain that runs north and south within private properties crossing 246th Street, 247th Street, 247th Place, and 248th Street. The proposed new water main will extend from 246th Street beyond the City boundaries, looping within the City of Los Angeles right of way and along Western Avenue (which is Caltrans’ right of way), and connecting back to the City of Lomita along 247th Street, 247th Place, 248th Street and Lomita Blvd. This project consists of constructing approximately 3,300 linear feet of PVC water pipeline and appurtenances (fire hydrants, valves, services, and fittings). The existing pipeline located in private property will be abandoned.

Design of the project was awarded to Onward Engineering in November 2021. The permit from Caltrans was approved in September 2022. The encroachment permit and traffic control plans were approved by the City of Los Angeles in December 2022. The permit fees for Lomita to work in the City of Los Angeles’ Right-of-Way is approximately \$318,247.20.

Onward Engineering has completed two rounds of potholing. The first round identified an unknown pipe requiring a new alignment and additional potholing. The second round of potholing has shown elevated levels of Lead in the area. On the third round of potholing and testing the soil report did not indicate contamination. Onward Engineering has completed the 100% alternate alignment drawings, The construction bid package is ready for release.

Progress	As of August 31, 2023
Percent Project completion	100% (of design)
Overall Project, invoiced/approved	\$136,069.37
Overall Project budget	\$1,499,916

Emergency Generator

This project consists of the selection and design of an emergency generator that will be capable of servicing the Appian Way Pump Station as needed. The design of this project

was awarded to AEPC Group in July 2022 and was completed in June 2023. City Council approved the design in June 2023, and authorized release for bidding.

The project bid for a permanent generator and load bank was given to Gen-Tech for a total of \$195,937.35. Gen-Tech will deliver the generator by December 2023 or January 2024. The load bank has a longer lead time and will be delivered by April 2024. A temporary load bank will be needed to test the permanent generator on arrival. To cover the long lead time of permanent generator, a short-term rental generator from United Rental will be delivered in September 2023.

Progress	As of August 31, 2023
Percent Project completion	100% (of design)
Overall Project, invoiced/approved	\$58,245.00
Overall Project budget	\$76,365

Narbonne Avenue Water Replacement and Street Rehabilitation Project

This project consists of constructing approximately 1,600 linear feet of PVC water pipeline on Narbonne Avenue from PCH to the southern end of the City of Lomita. The proposed watermain will be a new 8-inch PVC water main to provide improved flow, pressure, and fire protection. This new water main will replace the existing 1928 6-inch and 8-inch water main.

The design of the project was awarded to David Evans and Associates (DEA) in December 2022. DEA has performed a pavement analysis of the current conditions, and the 60% preliminary design package is complete. The pavement analysis report has three alternative choices. The Lomita engineering team is reviewing the options and will determine which alternative is the best value for the pavement lifecycle. DEA also plans to pothole various locations to determine depth of possible conflicting utilities. The final design is scheduled to be completed by the end of 2023.

Progress	As of August 31, 2023
Percent Project completion	60% (of design)
Overall Project, invoiced/approved	\$37,337.60
Overall Project budget	\$199,940

New Groundwater Well Feasibility Study

The purpose of this study is to identify preliminary locations where construction of a new groundwater well is feasible. The installation of a new well would minimize the City's long-term reliance on imported water and provide a contingency well in case of future adverse impacts to Lomita Well No. 5. The City currently has groundwater rights of 1,352-acre feet (ac-ft) in the West Coast Basin, and in its last year of normal operations, CY 2018, Well No. 5 only pumped 561 ac-ft of groundwater.

In February 2023, this study was awarded to Stetson Engineering, Inc. In June, the preliminary report was received, and staff have reviewed and provided feedback. The study and final report are expected in September 2023.

Progress	As of August 31, 2023
Percent Project completion	95%
Overall Project, invoiced/approved	\$44,146.75
Overall Project budget	\$63,135

Appian Way Pump Station Roof Project

This project consists of designing and constructing a new roof for the Appian Way Pump Station. The design contract has been awarded to Tetra Tech, Inc., and 100% of the design drawings have been submitted. Lomita engineering staff is reviewing the drawings.

Stephenson Center Maintenance Project

This project consists of design and construction for upgrades to the restroom facilities as well as restoration/replacement of the three-level roof at the Stephenson Center in Lomita Park. The Project design has been awarded to BOA Architecture; they have visited the site and provided preliminary drawings for the restroom layout to meet accessibility design requirements. BOA subcontractor visited the site and collected samples to check for any Asbestos or Lead Paint. The lab samples results will be in two weeks and based on the results BOA will complete the design.

Tom Rico Center Gymnasium & Railroad Museum Building Roof Replacement Project

This project consists of design and installation of new roof skin for the two buildings, upgrade of signs at the Railroad Museum, inspection, and test/treat the roof and the buildings for the termite infestation. Proposals have been received and city staff is evaluating for final selection of the design contract.

Engineering/Regulatory Updates

Encroachment Permit Review/Approval

For the month of August 2023, staff received and reviewed 12 encroachment permit applications from various utility companies, contractors, and residents. Permits were issued to 4 applicants. Public Works now has an on-line portal for encroachment permitting, available at <https://lomitaca.viewpointcloud.com/categories/1081>.

Stormwater

The Public Works Director from Lomita participated in the August Watershed Area Steering Committee (WASC) for South Santa Monica Bay, Safe Clean Water Program.

City staff worked with its consultant to provide preliminary data for the Dominguez Channel annual report, including details about landscaping of development projects within the City and calculated the level of effort for City staff to maintain stormwater features within the City.

As part of the NPDES/MS4 required outreach effort on stormwater, community members are encouraged to participate in "California Coastal Cleanup Day on September 23rd. Visit coastalcleanupday.org to learn more.

Public Safety and Traffic

Public Safety and Traffic Commission (PS&TC) did not meet in August. The Technical Traffic Advisory Committee received and discussed a new request. All new requests for traffic issue investigations are accepted through the on-line OpenGov portal and may be submitted here: <https://lomitaca.viewpointcloud.com/categories/1081>.

Public Works Field Operations Division (Parks/Street/Trees) Updates

Park staff crews applied herbicides for weed control at various park locations and Lomita Blvd medians. Street staff crews assisted in banner replacement, at the request of the Recreation Department. Additionally, street staff removed dead trees and vegetation in the 1800 block of 248th Street, and planted drought tolerant fox tail and jade plants as replacements. The street crew also completed the concrete parking lot repairs at Harbor Hills, following the water main break repair in early 2023.

Parks Division:

Mowed Park Grounds, number of times	44
Playground Safety Inspections	10
Raised Median/Planter Weeding	49
Park Grounds Fertilize	8
Museum/City Hall Grounds Maintenance	8
Sprinkler Repair/Replacement	34
Trimmed Hedges/Trees (City grounds)	45

Streets and Trees Division:

Trees Trimmed (by Crew)	44
Trees Trimmed (by Contractor)	0
Trees/Stumps Removed	0
Graffiti Locations Cleaned	48
Sidewalk Maintenance	211
Curb/Gutter Maintenance	24
City Drains Cleaned	53
Street Signs Replaced or Repaired	22
Potholes Filled / Patches	53
New work order requests	35
Backlog of work orders	9
Total Trees Planted	0

Reviewed by:



Gary Y. Sugano
Assistant City Manager

Approved by:



Ryan Smoot
City Manager

Prepared by:



Carla Dillon, PE
Public Works Director



CITY OF LOMITA CITY COUNCIL REPORT

TO: City Council **Item No. 7h**
FROM: Ryan Smoot, City Manager
PREPARED BY: Susan Kamada, Administrative Services Director
MEETING DATE: September 19, 2023
SUBJECT: August 2023 Treasury and Investment Report

RECOMMENDATION

Receive and file the Treasury and Investment Report.

BACKGROUND

Pursuant to Section 41004 of the Government Code of the State of California, the City Treasurer is required to submit a monthly report of all receipts, disbursements and fund balances. The first page of the report summarizes the investment activity for the month and distribution by type of investment, held by the City. The second and third page lists all investments with original maturities exceeding one year as of the month ended August 31, 2023. The fourth page of the report provides a summary of the beginning balance, total receipts, total disbursements, ending balance for all funds, and a listing, by fund, of all month end fund balances.

In summary, all investments of the City of Lomita are in compliance with both the Government Code and our Investment Policy. In addition, the City has sufficient liquidity to meet its expenditure requirements for the ensuing six months.

20.85% of the City's funds are with the State of California Local Agency Investment Fund (LAIF). The remaining funds of the City of Lomita are in active checking accounts, money market funds, U.S. Treasuries, Federal Agency Securities, Corporate Bonds, and FDIC-insured Negotiable Certificates of Deposit that are in compliance with the California Government Code and the City's Investment Policy. The current value of each account is obtained from actual monthly statements for the period ending August 31, 2023.

OPTIONS:

None, information only.

FISCAL IMPACT

None.

ATTACHMENT

1. Treasury and Investment Report for August 2023

Reviewed by:



Gary Y. Sugano
Assistant City Manager

Approved by:



Ryan Smoot
City Manager

Prepared by:



Susan Kamada
Administrative Services Director



City of Lomita Investment Portfolio Report August 31, 2023

Summary of Cash & Investments	Distribution of Cash &				Gain (Loss) on
	Investments	Book Value	Market Value*	Interest Earned	Investment
Local Agency Investment Fund (LAIF)	20.8523%	6,496,669.55	6,496,669.55	0.00	0.00
Certificate of Deposit - Negotiable	46.3125%	14,429,000.00	13,671,919.63	34,827.54	0.00
Federal Agency Securities	16.8508%	5,250,000.00	4,949,265.00	10,500.00	0.00
Commerical Paper	6.4194%	2,000,000.00	1,772,735.00	2,875.00	0.00
Net Cash Equivalents	0.0000%	0.00	0.00	0.00	0.00
Total Pooled Investments	90.44%	28,175,669.55	26,890,589.18	48,202.54	0.00
City of Lomita General Account DDA	9.56%	2,980,043.79	2,980,043.79	0.00	0.00
Total Cash	9.56%	2,980,043.79	2,980,043.79	0.00	0.00
Total Cash & Investments	100.00%	31,155,713.34	29,870,632.97	48,202.54	0.00

City of Lomita Distribution of Pooled Cash

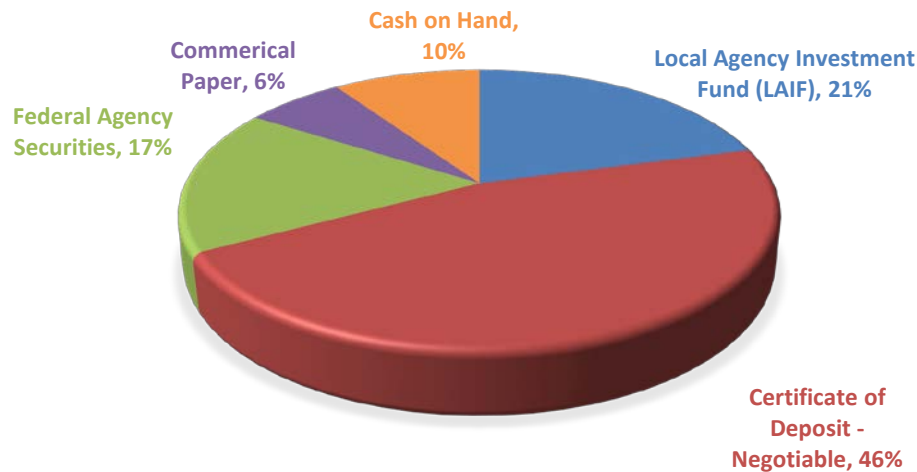

Month to Date & Fiscal Year to Date Interest Earned/ Gain (Loss) on Total Investments

	<u>MTD</u>	<u>YTD</u>
Jul-23	40,936.35	40,936.35
Aug-23	48,202.54	89,138.89
Sep-23	-	89,138.89
Oct-23	-	89,138.89
Nov-23	-	89,138.89
Dec-23	-	89,138.89
Jan-24	-	89,138.89
Feb-24	-	89,138.89
Mar-24	-	89,138.89
Apr-24	-	89,138.89
May-24	-	89,138.89
Jun-24	-	89,138.89
	89,138.89	89,138.89

*The Governmental Accounting Standards Board (GASB) has established Statement No. 31 for setting investment valuation standards. We report the unrealized gain/(loss) monthly and book realized gain/(loss) at year end as a GASB 31 requirement.

GASB 31 is a reporting requirement that reports the "Fair Value" of investments held in our portfolio. Fair value is the amount at which a financial instrument (investment) could be exchanged in a current transaction between willing parties at current market prices. It is important to understand the relationship between prevailing interest rates and fixed coupon investments. As market interest rates fall, the "Fair Value" of held securities will rise (unrealized Gains). The opposite occurs as market interest rates rise (market prices of held investments will fall). It should be noted that investments held in the city pool are to be held until maturity so both gains and losses (unrealized) will not be taken.



**City of Lomita
Investment Portfolio Report
August 31, 2023**

Account/ Investment Title & Description	Account #/ CUSIP	Settlement Date	Maturity Date	Yield to Maturity	Beginning Face Amount/Shares	Beginning Market Value	Buy Principal	Sell Principal	Change in Market Value	Ending Market Value	Ending Face Amount/Shares	Interest Earned / (Accrued)	Realized Gain / (Loss) On Investment
Local Agency Investment Fund (LAIF)													
City of Lomita	XX-XX-469		N/A	3.434%	6,496,669.55	6,496,669.55	-	-	-	6,496,669.55	6,496,669.55	-	-
Sub Total / Average				3.434%	6,496,669.55	6,496,669.55	-	-	-	6,496,669.55	6,496,669.55	-	-
Certificate of Deposit - Negotiable													
PCSB Bank	69324MAL9	02/21/20	02/21/24	1.650%	248,000.00	243,044.96	-	-	558.00	243,602.96	248,000.00	347.54	
Third Federal S & L Assn	88413QDA3	08/13/21	08/13/24	0.500%	249,000.00	236,634.66	-	-	709.65	237,344.31	249,000.00	617.38	
Raymond James Bank NA	75472RBB6	02/14/20	02/14/25	1.750%	248,000.00	234,640.24	-	-	329.84	234,970.08	248,000.00	2,152.16	
Liberty Federal Credit Union	53052LAP4	03/24/23	03/24/25	5.350%	248,000.00	247,667.68	-	-	(307.52)	247,360.16	248,000.00	1,126.87	
Lafayette FCU	50625LAY9	03/31/22	03/31/25	2.200%	249,000.00	236,178.99	-	-	313.74	236,492.73	249,000.00	466.61	
Direct Federal Credit Union	25460FDZ6	02/01/23	05/01/25	4.700%	248,000.00	245,001.68	-	-	(198.40)	244,803.28	248,000.00	989.96	
JPMorgan Chase Bank NA	48128WCJ2	12/03/21	05/16/25	0.800%	248,000.00	228,566.72	-	-	565.44	229,132.16	248,000.00		
Institution for Savings Newburyport MA	45780PBL8	05/20/22	05/20/25	3.100%	247,000.00	237,176.81	-	-	98.80	237,275.61	247,000.00	650.32	
Axiom Bank Maitland FL	05464LBR1	11/30/21	06/13/25	0.700%	249,000.00	228,148.74	-	-	550.29	228,699.03	249,000.00	148.04	
Bank of Princeton	064520BE8	06/26/20	06/26/25	0.600%	210,000.00	191,751.00	-	-	474.60	192,225.60	210,000.00	107.01	
Flushing Bank	34387AFF1	11/04/22	11/04/25	4.700%	249,000.00	245,506.53	-	-	(321.21)	245,185.32	249,000.00	993.95	
BankUnited NA	066519RX9	12/08/21	12/08/25	1.250%	248,000.00	225,645.28	-	-	317.44	225,962.72	248,000.00		
USAlliance FCU	90352RCD5	01/28/22	01/28/26	1.350%	249,000.00	227,302.39	-	-	(1,107.30)	226,195.09	249,000.00	285.50	
Liberty First Credit Union	530520AF2	02/03/23	02/03/26	4.400%	249,000.00	244,211.73	-	-	(375.99)	243,835.74	249,000.00	951.66	
Truliant	89789AAH0	03/22/23	03/23/26	5.150%	248,000.00	247,082.40	-	-	(548.08)	246,534.32	248,000.00	1,084.75	
Pentagon FCU	70962LBK7	03/28/22	03/30/26	2.050%	249,000.00	228,933.09	-	-	24.90	228,957.99	249,000.00	433.53	
Kansas State Bank	50116CCV9	03/31/22	03/31/26	2.300%	249,000.00	230,461.95	-	-	(2.49)	230,459.46	249,000.00	486.40	
Nelnet Bank	64034KAC5	04/15/21	04/15/26	0.700%	248,000.00	219,591.60	-	-	292.64	219,884.24	248,000.00		
Community West Bank NA	20415QHQ5	04/23/21	04/23/26	0.700%	248,000.00	219,135.28	-	-	250.48	219,385.76	248,000.00	147.44	
State BK India New York NY	856285VS7	05/19/21	05/19/26	1.000%	247,000.00	219,760.84	-	-	192.66	219,953.50	247,000.00		
Toyota Financial Savings Bank	89235MLD1	07/22/21	07/22/26	0.950%	248,000.00	218,884.80	-	-	131.44	219,016.24	248,000.00		
Medallion BK Salt Lake City	58404DLD1	07/30/21	07/30/26	0.800%	248,000.00	217,684.48	-	-	148.80	217,833.28	248,000.00		
Sallie Mae Bank	795451AK9	08/11/21	08/11/26	1.100%	248,000.00	219,569.28	-	-	(17.36)	219,551.92	248,000.00	1,352.79	
Metro Credit Union	59161YAN6	02/18/22	08/18/26	1.600%	249,000.00	223,519.83	-	-	(47.31)	223,472.52	249,000.00	338.37	
Texas Exchange Bank	88241TML1	11/26/21	11/27/26	1.200%	249,000.00	218,699.19	-	-	(27.39)	218,671.80	249,000.00	253.78	
Beal Bank USA	07371CH69	03/02/22	02/24/27	2.050%	248,000.00	223,115.68	-	-	(190.96)	222,924.72	248,000.00		
Capital One Bank USA NA	14042TFP7	04/27/22	04/27/27	2.900%	248,000.00	229,360.32	-	-	(376.96)	228,983.36	248,000.00		
Morgan Stanley Bank	61773TDN0	04/29/22	04/29/27	3.000%	246,000.00	228,354.42	-	-	(396.06)	227,958.36	246,000.00		
Discover Bank	254673G83	06/14/22	06/14/27	3.150%	246,000.00	229,222.80	-	-	(440.34)	228,782.46	246,000.00		
The Dart Bank	237412AN1	06/08/22	06/15/27	3.250%	249,000.00	232,797.57	-	-	(483.06)	232,314.51	249,000.00	687.31	
Forbright Bank	34520LAT0	11/02/22	11/02/27	4.600%	249,000.00	244,074.78	-	-	(550.29)	243,524.49	249,000.00	972.81	
Alliant Credit Union	01882MAC6	12/30/22	12/30/27	5.000%	248,000.00	246,670.72	-	-	(622.48)	246,048.24	248,000.00	1,053.15	
First Technology Federal	33715LEL0	02/03/23	02/03/28	5.000%	248,000.00	246,333.44	-	-	(476.16)	245,857.28	248,000.00	1,053.15	
Alaska USA Federal Credit Union	011852AE0	03/08/23	03/08/28	4.600%	249,000.00	243,330.27	-	-	(555.27)	242,775.00	249,000.00	972.81	
Central Valley Community Bank	15568PAL0	03/31/23	03/31/28	5.300%	248,000.00	247,712.32	-	-	(277.76)	247,434.56	248,000.00	1,116.34	
Pacific Western Bank	69506YYD5	04/05/23	04/05/28	5.650%	243,000.00	243,563.76	-	-	(315.90)	243,247.86	243,000.00		
Austin TelCo FCU	052392BK2	08/12/22	08/11/23	3.200%	249,000.00	248,858.07	-	(249,000.00)	141.93	-	-	895.04	
General Electric Credit Union	369674CG 9	01/30/23	01/30/24	5.000%	248,000.00	247,692.48	-	-	(111.60)	247,580.88	248,000.00	1,053.15	
Grow Financial Federal Credit Union	39981MAC6	03/24/23	03/25/24	5.350%	248,000.00	248,007.44	-	-	(156.24)	247,851.20	248,000.00	1,126.87	
Wells Fargo Bank	949763ZA7	04/18/19	04/10/24	2.850%	245,000.00	240,798.25	-	-	362.60	241,160.85	245,000.00	593.03	
Live Oak Bkg Co	538036HY3	02/12/20	08/12/24	1.700%	245,000.00	235,677.75	-	-	573.30	236,251.05	245,000.00	353.74	
Capital One Natl Assn	14042RNE7	08/23/19	08/21/24	2.000%	245,000.00	236,309.85	-	-	411.60	236,721.45	245,000.00	2,497.47	
Connexus CU	20825WCK4	08/25/23	08/23/24	5.500%	-	-	248,000.00	-	(71.92)	247,928.08	248,000.00		
Morgan Stanley Private Bk Natl Assn	61760AX53	09/05/19	09/05/24	1.900%	100,000.00	96,216.00	-	-	197.00	96,413.00	100,000.00		
Synchrony Bank	87165FF58	11/30/21	11/29/24	0.850%	245,000.00	230,522.95	-	-	632.10	231,155.05	245,000.00		
Workers Federal Credit Union	98138MBC3	01/27/23	01/27/25	4.700%	249,000.00	246,328.23	-	-	(159.36)	246,168.87	249,000.00	993.95	
Enerbank USA Salt	29278TMZ0	02/14/20	02/14/25	1.650%	245,000.00	231,302.05	-	-	416.50	231,718.55	245,000.00	343.34	
Merrick Bank	59013QOE9	11/30/21	05/30/25	0.900%	245,000.00	225,728.30	-	-	507.15	226,235.45	245,000.00	187.27	
Spokane Teachers Credit Union	849061AA4	11/23/22	11/24/25	5.000%	248,000.00	246,107.76	-	-	(396.80)	245,710.96	248,000.00		



**City of Lomita
Investment Portfolio Report
August 31, 2023**

Account/ Investment Title & Description	Account #/ CUSIP	Settlement Date	Maturity Date	Yield to Maturity	Beginning Face Amount/Shares	Beginning Market Value	Buy Principal	Sell Principal	Change in Market Value	Ending Market Value	Ending Face Amount/Shares	Interest Earned / (Accrued)	Realized Gain / (Loss) On Investment
Eaglemark Savings Bank	27004PBD4	04/07/21	04/07/26	0.700%	245,000.00	217,131.25	-	-	296.45	217,427.70	245,000.00		
Greenstate Credit Union	39573LBL1	06/16/21	06/16/26	0.900%	249,000.00	220,041.30	-	-	154.38	220,195.68	249,000.00	190.33	
UBS Bk USA Salt Lake	90348JQ29	07/14/21	07/14/26	0.900%	249,000.00	219,391.41	-	-	124.50	219,515.91	249,000.00	190.33	
Bank of Frankewing	06221LAE3	11/09/22	11/09/26	4.950%	248,000.00	246,169.76	-	-	(721.68)	245,448.08	248,000.00	1,042.62	
Baxter Credit Union	07181JAU8	11/22/22	11/23/26	5.000%	248,000.00	246,521.92	-	-	(734.08)	245,787.84	248,000.00	1,053.15	
Celtic Bank	15118RZT7	11/30/22	11/30/26	4.800%	249,000.00	246,009.51	-	-	(702.18)	245,307.33	249,000.00	1,015.10	
Dept of Commerce Federal CU	24951TAT2	05/13/22	05/13/27	3.250%	249,000.00	233,016.69	-	-	(470.61)	232,546.08	249,000.00	687.31	
BMO Harris Bank NA	05600XFW5	06/15/22	06/15/27	3.300%	249,000.00	233,203.44	-	-	(488.04)	232,715.40	249,000.00	697.88	
Numerica Credit Union	67054NBC6	11/04/22	11/04/27	4.950%	248,000.00	246,397.92	-	-	(610.08)	245,787.84	248,000.00	1,042.62	
University Bk Ann	914098DQ8	04/03/23	04/03/28	4.850%	248,000.00	244,768.56	-	-	(597.68)	244,170.88	248,000.00	1,021.56	
Customers Bank	23204HNZ7	05/31/23	05/31/28	4.450%	244,000.00	241,081.76	-	-	383.08	241,464.84	244,000.00		
Sub Total / Average				2.896%	14,430,000.00	13,676,618.88	248,000.00	(249,000.00)	(3,699.25)	13,671,919.63	14,429,000.00	34,827.54	-
Federal Agency Securities													
Federal Home LN BKS	3130APXC4	12/10/21	12/10/24	1.100%	1,000,000.00	941,830.00	-	-	5,280.00	947,110.00	1,000,000.00		
Federal Home LN BKS	3130ALMM3	03/30/21	03/30/26	1.000%	250,000.00	226,227.50	-	-	167.50	226,395.00	250,000.00		-
Federal Home LN BKS	3130AR2B6	03/08/22	03/08/27	2.375%	500,000.00	459,065.00	-	-	1,565.00	460,630.00	500,000.00		
Federal Home LN BKS	3130ARDY4	03/29/22	03/29/27	2.500%	500,000.00	460,495.00	-	-	1,490.00	461,985.00	500,000.00		
Federal Home LN BKS	3130ARGQ8	04/14/22	04/14/27	2.875%	250,000.00	233,330.00	-	-	642.50	233,972.50	250,000.00		
Federal Home LN BKS	3130ASD22	06/29/22	06/29/27	3.590%	250,000.00	237,437.50	-	-	635.00	238,072.50	250,000.00		
Federal Home LN MTG	3134GXL28	08/17/22	08/17/27	4.150%	250,000.00	240,662.50	-	-	595.00	241,257.50	250,000.00	5,187.50	
Federal Home LN MTG	3134GXQ23	08/25/22	08/25/27	4.250%	250,000.00	241,202.50	-	-	575.00	241,777.50	250,000.00	5,312.50	
Federal Home LN MTG	3134GY3F7	11/22/22	11/22/27	5.125%	250,000.00	246,660.00	-	-	372.50	247,032.50	250,000.00		
Federal Home LN MTG	3134GYF31	01/30/23	01/27/28	5.100%	250,000.00	245,195.00	-	-	302.50	245,497.50	250,000.00		
Federal Farm Credit Bank	3133ENCD0	11/30/21	10/27/25	1.040%	500,000.00	459,410.00	-	-	(120.00)	459,290.00	500,000.00		
Federal Farm Credit Bank	3133EMB76	05/26/21	05/26/26	0.950%	500,000.00	449,900.00	-	-	185.00	450,085.00	500,000.00		-
Federal Home LN MTG	3134GYTP7	06/15/23	06/15/28	5.500%	500,000.00	498,650.00	-	-	(2,490.00)	496,160.00	500,000.00		-
Sub Total / Average				3.043%	5,250,000.00	4,940,065.00	-	-	9,200.00	4,949,265.00	5,250,000.00	10,500.00	-
Commerical Paper													
Bank of America Corp A2	06048WM31	05/28/21	05/28/26	1.250%	1,000,000.00	879,100.00	-	-	11,180.00	890,280.00	1,000,000.00		
Goldman Sachs Corp A2	38150AFK6	04/30/21	04/30/26	1.550%	500,000.00	444,025.00	-	-	1,130.00	445,155.00	500,000.00		
JPMorgan Chase & Co	48128G4R8	08/17/21	08/17/26	1.150%	500,000.00	436,185.00	-	-	1,115.00	437,300.00	500,000.00	2,875.00	
Sub Total / Average				1.317%	2,000,000.00	1,759,310.00	-	-	13,425.00	1,772,735.00	2,000,000.00	2,875.00	-
Net Cash Equivalents*													
Stifel	XXXX4891	N/A	N/A	0.000%	-	N/A	N/A	N/A	N/A	-	-	N/A	N/A
Multibank Securities Inc	XXXXX5544	N/A	N/A	0.000%	-	N/A	N/A	N/A	N/A	-	-	N/A	N/A
Sub Total / Average				0.000%	-	-	-	-	-	-	-	-	-
Total / Average - Investments				2.39%	28,176,669.55	26,872,663.43	248,000.00	(249,000.00)	18,925.75	26,890,589.18	28,175,669.55	48,202.54	-
Demand Deposit Account (DDA)													
Pacific Western - General Account	XXXX259	N/A	N/A	0.000%	3,011,626.06	N/A	N/A	N/A	N/A	3,011,626.06	3,011,626.06	N/A	N/A
(Outstanding Checks)		N/A	N/A		(31,582.27)	N/A	N/A	N/A	N/A	(31,582.27)	(31,582.27)	N/A	N/A
Sub Total / Average				0.000%	2,980,043.79	-	-	-	-	2,980,043.79	2,980,043.79	-	-
Total /Cash & Investments					31,156,713.34	26,872,663.43	248,000.00	(249,000.00)	18,925.75	29,870,632.97	31,155,713.34	48,202.54	-

*Unpaid investment interest held in brokerage account.



City of Lomita Investment Portfolio Report August 31, 2023

Previous Balance	\$	3,514,376.49
Deposits		1,934,832.63
Disbursements		(2,428,538.04)
Adjustments		(9,045.02)
Current Balance		3,011,626.06

GENERAL LEDGER CASH BALANCES		
General Fund - City Operations		
General Fund - City Operations including LAIF and Investments	100	7,051,519.52
Sub Total - General Fund - City Operations including LAIF and Investments		7,051,519.52
Special Revenue Funds		
OPEB Trust Fund - Retiree Health Care	201	256,548.01
Pension Stabilization Fund	202	1,346,646.01
Economic Development	203	746,506.98
General Plan Update	204	804,754.30
Gas Tax Fund - Street Maintenance	205	1,325,831.38
Measure R Local Fund - Street Projects	207	737,880.77
Measure R Highway Fund - Street Projects	208	(106,536.84)
Measure M Fund - Street Projects	209	791,530.09
Economic Stabilization	210	500,000.00
Measure W Fund - Safe Clean Water Program	211	505,111.91
American Rescue Plan	212	1,336,976.00
CDBG Fund - Housing Programs	215	1.74
Proposition A Fund - Transportation Projects	220	687,435.44
Proposition C Fund - Transportation Projects	225	2,515,428.57
Transportation Development Act Article 3- Transportation Projects	230	-
Air Quality Fund - Air Quality Projects	235	65,162.15
Landscape Maintenance Fund - Landscape Maintenance District	245	9,202.63
Park Facilities Fee Fund - Quimby Funds	250	578,946.74
Park Athletic Fund - Park Athlete Programs	255	102,661.72
Park Grant Fund - Park Improvement Programs	257	22,799.94
Lomita Manor Fund - Federal Housing Program	260	197,505.04
CA Law Enf. Equip. Program (CLEEP) Fund - Public Safety Equip.	276	6,351.40
Sub Total - Special Revenue Funds		12,430,743.98
Capital Improvement Funds		
Capital Improvement Fund - Capital Improvement Projects	310	188,430.26
Street Improvement Fund - Street Improvement Projects	311	2,109,207.64
Facilities Improvement Fund - Facilities Improvement Projects	312	367,744.23
Stephenson Center Fund - Facilities Improvement Projects	313	85,744.47
Sub Total - Capital Improvement Funds		2,751,126.60



City of Lomita Investment Portfolio Report August 31, 2023

Previous Balance	\$	3,514,376.49
Deposits		1,934,832.63
Disbursements		(2,428,538.04)
Adjustments		(9,045.02)
Current Balance		3,011,626.06

Proprietary Funds		
Water Operations Fund - Water Operations	510	3,299,978.71
Water Capital Fund - Water Capital Projects	520	2,699,550.42
Rate Stabilization - Cypress Reservoir Bond	530	125,000.00
Internal Service Fund - Equipment Replacement	610	1,408,504.29
PK Equipment Replacement Fund	611	759,198.27
Sewer Replacement Fund	612	608,480.00
Sub Total - Proprietary Funds		8,900,711.69
Trust and Agency Funds		
Museum Foundation Fund - Railroad Museum Programs	720	21,391.55
Tom Rico Memorial Fund - Park Program Scholarships	730	220.00
Sub Total - Trust & Agency Funds		21,611.55
Total		31,155,713.34
Pooled Cash	999	(28,144,087.28)
Grand Total		3,011,626.06



CITY OF LOMITA CITY COUNCIL REPORT

TO: City Council **Item No. 7i**

FROM: Ryan Smoot, City Manager

PREPARED BY: Laura MacMorran, Associate Planner

MEETING DATE: September 19, 2023

SUBJECT: Second Reading and Adoption of Ordinance No. 856 for Zoning Text Amendment No. 2023-07 Amendment Lomita Municipal Code Title XI (Planning and Zoning) to Create Mixed-Use Overlay District Regulations for Four or Fewer Residential Unit Developments within the Downtown, Commercial (D-C) Zone

RECOMMENDATION

Adopt the ordinance and find the project categorically exempt from the California Environmental Quality Act (CEQA).

BACKGROUND

On September 5, 2023, the City Council introduced on first reading an ordinance amending Lomita's Municipal Code Article 58 (Mixed Use Overlay District) to update regulations, remove the minimum lot size requirement for four-or-fewer-residential-unit developments within the D-C (Downtown, Commercial) Zone within the Mixed-Use Overlay District, and Article 15 (Definitions) of Lomita Municipal Code Title XI (Planning and Zoning). This agenda item is to approve the second reading and adoption of the ordinance.

OPTIONS:

1. Approve the attached ordinance.
2. Do not approve the ordinance.
3. Provide staff with further direction.

FISCAL IMPACT

None.

ATTACHMENTS

1. Ordinance No. 856

Reviewed by:

Gary Sugano

Gary Y. Sugano
Assistant City Manager

Approved by:

Ryan Smoot

Ryan Smoot
City Manager

Reviewed by:

Brianna Rindge

Brianna Rindge, AICP
Community & Economic Development Director

Prepared by:

Laura MacMorran

Laura MacMorran
Associate Planner

ORDINANCE NO. 856

AN ORDINANCE OF THE CITY COUNCIL OF THE CITY OF LOMITA, CALIFORNIA, APPROVING ZONING TEXT AMENDMENT 2023-07 AMENDING LOMITA MUNICIPAL CODE TITLE XI (PLANNING AND ZONING), CHAPTER 1 (ZONING), REVISING THE CITY'S REGULATIONS FOR MIXED-USE OVERLAY DISTRICT TO UPDATE STANDARDS; TO ALLOW MIXED-USE DEVELOPMENTS CONTAINING FOUR OR FEWER UNITS WITHIN THE DOWNTOWN COMMERCIAL (D-C) ZONE; TO DEFINE A TERM AND A DETERMINATION THAT THE PROJECT IS CATEGORICALLY EXEMPT FROM THE CALIFORNIA ENVIRONMENTAL QUALITY ACT (CEQA)

THE CITY COUNCIL OF THE CITY OF LOMITA HEREBY ORDAINS AS FOLLOWS:

Section 1. Recitals.

- A. Chapter 1 of Title XI of Lomita Municipal Code establishes allowable uses, definitions, and development standards of properties within all zoning districts in the City.
- B. On July 10, 2023 and August 14, 2023, the Planning Commission held duly noticed public hearings on Zone Text Amendment No. 2023-07 where public testimony was accepted on the item and on August 14, 2023 recommended City Council approval.
- C. On September 5, 2023, City Council held a duly noticed public hearing to consider the proposed text amendment to Title XI of the Lomita Municipal Code to amend mixed-use standards of development as necessary to allow for four or fewer units on properties with less than 10,000 square feet, and to establish affordable housing incentives in the Downtown-Commercial Zone with a Mixed-Use Overlay.

The Recitals above are true and correct and are hereby adopted as findings as if fully set forth herein.

Section 2. General Plan.

This Ordinance's amendments to Title XI of the Lomita Municipal Code are consistent with, and in furtherance of, the City's adopted General Plan as they effectuate the following Policies of the General Plan:

- A. Housing Element Policy 2.4 which is to promote and encourage innovation and creativity in housing development through regulations that increase transparency and flexibility in the development approval process.

- B. Housing Element Program 7 requires the City to evaluate a range of incentive-based and regulatory approaches to facilitate the development of housing for lower-income households. One specific objective is to “Improve development regulations intended to incentivize affordable and mixed-income housing development through regulatory inducements such as incentive zoning paired with objective development standards, or process incentives such as technical assistance in exchange for affordable housing no later than fall 2023.”

Section 3. Environmental Review.

The City Council finds and determines that the adoption of this Ordinance regarding Mixed Use Overlay standards of development in the Downtown Commercial Zone is exempt from the California Environmental Quality Act (CEQA) pursuant to Section 15061(b)(3) of the CEQA Guidelines. Section 15061(b)(3) states that CEQA applies only to projects that have the potential for causing a significant effect on the environment. The Ordinance will not have a significant effect on the environment because only new standards consistent with the existing municipal code and State Law are provided and does not propose any physical construction.

THE CITY COUNCIL OF THE CITY OF LOMITA HEREBY ORDAINS AS FOLLOWS:

Section 4. Zoning Amendments.

Based on the foregoing, the City Council hereby approves the following amendments to the Lomita Municipal Code:

- A. Section 11-1.15.03(C) of Title XI of the Lomita Municipal Code is amended to read as follows:

“Clear vision triangle shall mean an unoccupied triangular area located at the intersection of two vehicular passageways composed of either two streets, a street and an alley, a street and a driveway, or a driveway and a sidewalk. Two perpendicular triangle legs are measured from the corner intersection of property lines for a minimum distance of 10 feet each way along the lot line(s), or driveway based on the situation. The third leg of the triangle is a line joining the ends of the other two legs. Such triangular area shall remain clear of obstructions between three and 10 feet above grade.”

- B. Section 11-1.58.06 of Title XI of the Lomita Municipal Code is amended to read as follows:

“Sec. 11-1.58.06. Standards of development

Premises within the mixed-use overlay zone shall be subject to the development standards prescribed in this section and those standards contained in part 6, "General Standards of Development."

Projects that are not considered mixed-use are subject to the underlying zoning regulations of its applicable zone.

(A) Mixed-Use Projects with Five (5) or More Residential Units

- (1) *Minimum lot size.* The minimum lot size for mixed-use developments shall be ten thousand (10,000) square feet.
- (2) *Yards. and sightlines.*
 - (a) *Front yard.* None required.
 - (b) *Side yard.* None required, except that a building exceeding sixteen (16) feet in height on a lot or parcel in the mixed-use overlay zone which has a side lot line adjoining property in a residential zone shall have a side setback not less than ten (10) feet.
 - (c) *Rear yard.* None required, except that a building exceeding sixteen (16) feet in height on a lot or parcel in the mixed-use overlay zone which has a rear lot line adjoining property in a residential zone shall have a rear setback not less than ten (10) feet.
 - (d) *Corner lots.* To ensure adequate visibility for vehicles turning a corner, a clear vision triangle shall be created with ten (10) foot-long perpendicular legs.
- (3) *Minimum unit size.*

Studio — Five hundred (500) square feet;
One bedroom — Seven hundred (700) square feet;
Two (2) bedrooms — Nine hundred (900) square feet;
Additional bedrooms — Two hundred (200) additional square feet per bedroom.
- (4) *Building height.* No lot or parcel of land in the mixed-use overlay zone shall have a building or structure in excess of thirty-five (35) feet.
- (5) *Percentage of nonresidential uses.* Percentage of nonresidential uses for mixed-use projects shall be a minimum of thirty (30) percent. Mixed-use projects shall be consistent with the definition in Section 11-1.58.02. A deviation from this requirement may be granted subject to conditional use permit.
- (6) *Off-street parking and loading.* For new mixed-use development, the commercial component shall have off-street parking and loading pursuant to Article 66, "Off-Street Parking, Storage and Loading." The parking ratio for the residential component of mixed-use projects is as follows. Residential parking may be met by covered or open parking spaces.

Units between five hundred (500) and seven hundred (700) square feet
— One space;

Units seven hundred one (701) square feet and greater — Two (2) spaces;

Guest parking — .25 spaces per unit.

- (7) *Ground floor building coverage.* For visual interest at the pedestrian level, at least fifty (50) percent of the total ground floor building frontage of any new or reconstructed building facing the public street shall have the following: windows with clear glass, recessed entries, residential stoops, or recesses for outdoor dining areas. To calculate the total ground-floor frontage, use the length of the building frontage along the pedestrian realm times the first-floor height from floor to ceiling.
- (8) *Open space.*
 - (a) Recreation and open space shall be provided for each mixed-use project. The required minimum amount of open space for a mixed-use project is two hundred (200) square feet per unit. The minimum open space may be met through a combination of common and private open space. All required open space shall be useable.
 - (b) A minimum of twenty-five (25) percent of all open space shall be planted area including trees, shrubs and gardens. Planters and planting containers may be counted toward this requirement.
 - (c) Common open space shall require a minimum width of ten (10) feet and be a minimum of two hundred (200) square feet in area.
 - (d) Projects that propose a public open space component as part of a mixed-use project may request a waiver from the open space requirement pursuant to Article 70 (Zoning Ordinance Administration).
- (9) *Utilities.* All new utilities shall be placed underground.
- (10) *Satellite antennas.* Satellite antennas when fully screened from the public right-of-way may be ground or roof mounted but may not exceed the height limit of buildings or structures in this zone.
- (11) *Walls.*
 - (a) Each lot or parcel of land in the mixed-use overlay zone which has a side or rear lot line adjoining property in a residential zone shall have a solid masonry wall, not less than six (6) feet in height, established along said side and rear lot lines except as otherwise provided in section 11-1.66.08(1) and except where such adjoining property is used in conjunction with such commercial lot.
 - (b) No wall shall be required if the building is located on a property line adjoining residential zones. However, windows shall not be located on the side of a commercial building which adjoins residential zones.

(B) Mixed-Use Projects with Four (4) or Less Residential Units in the Downtown, Commercial (D-C) Zone

(1) Definitions. For purposes of this subsection, the following definitions will apply:

(a) *Concession* shall mean a reduction in development standards or a modification of zoning code requirements or architectural design requirements that exceed the minimum building standards approved by the California Building Standards Commission.

(b) *Incentive* shall mean a modification to development standards, of zoning code requirements or architectural design requirements.

(2) Development standards.

(a) *No minimum lot size.*

(b) *Yards and sightlines.*

(i) *Front yard.* None required.

(ii) *Side yard.* None required, except that a building exceeding sixteen (16) feet in height on a lot or parcel in the mixed-use overlay zone which has a side lot line adjoining property in a residential zone shall have a side setback not less than ten (10) feet.

(iii) *Rear yard.* None required, except that a building exceeding sixteen (16) feet in height on a lot or parcel in the mixed-use overlay zone which has a rear lot line adjoining property in a residential zone shall have a rear setback not less than ten (10) feet.

(iv) *Corner lots.* To ensure adequate visibility for vehicles turning a corner, a clear vision triangle shall be created with ten (10) foot-long perpendicular legs.

(v) *Exemption.* Existing buildings converting existing floor area or up to one-hundred fifty (150) square feet for ingress/egress shall be exempt from setback and sightline requirements.

(3) Further development standards.

(a) *Maximum average unit size (no minimum size greater than CA Health & Safety Code Section 17958.1).*

Studio — Five hundred fifty (550) square feet;

One (1) bedroom— Eight hundred (800) square feet;

Two (2) bedrooms— One thousand (1,000) square feet;

Additional bedrooms — Two hundred (200) additional square feet per bedroom.

- (b) *Building height.* No lot or parcel of land in the mixed-use overlay zone shall have a building or structure in excess of thirty-five (35) feet. Existing buildings converting existing space shall be exempt from height requirements.
- (c) *Percentage of nonresidential uses.* Percentage of nonresidential uses shall be a minimum of thirty (30) percent. Mixed-use projects shall be consistent with the definition in Section 11-1.58.02. A deviation from this requirement may be granted subject to conditional use permit.
- (d) *Off-street parking and loading.* For new mixed-use development, the commercial component shall have off-street parking and loading pursuant to Article 66, "Off-Street Parking, Storage and Loading." The parking ratio for the residential component of mixed-use projects is as follows. Parking may be met by covered or open parking spaces, but not enclosed parking spaces.
 - Units between five hundred (500) and seven hundred (700) square feet — One space;
 - Units seven hundred one (701) square feet and greater — Two (2) spaces;
 - Guest parking — One (1) space total per project.
- (e) *Building ground floor*
 - (i) Fronting Narbonne Avenue or Lomita Boulevard, only nonresidential uses may be located on the ground floor, with the exception of ingress/egress for units located above the ground floor. Commercial ground floor area shall not be converted to residential ground floor area, with the exception of ingress/egress for units located above the ground floor.
 - (ii) *Building coverage.* For visual interest at the pedestrian level, at least fifty (50) percent of the total ground floor building frontage of any new or reconstructed building facing the public street shall have the following: windows with clear glass, recessed entries, residential stoops, or recesses for outdoor dining areas. To calculate the total ground-floor frontage, use the length of the building frontage along the pedestrian realm times the first-floor height from floor to ceiling.
- (f) *Open space.*
 - (i) Recreation and open space shall be provided for each mixed-use project. The required minimum amount of open space for a mixed-use project is two hundred (200) square feet per unit. The minimum open space may be met through a combination of common and private open space. All required open space shall be useable.

- (ii) A minimum of twenty-five (25) percent of all open space shall be planted area including trees, shrubs and gardens. Planters and planting containers may be counted toward this requirement.
 - (iii) Common open space shall require a minimum width of ten (10) feet and be a minimum of two hundred (200) square feet in area.
 - (g) *Utilities.* All new utilities shall be placed underground.
 - (h) *Satellite antennas.* Satellite antennas when fully screened from the public right-of-way may be ground or roof mounted but may not exceed the height limit of buildings or structures in this zone.
 - (i) *Walls.*
 - (i) Each lot or parcel of land in the mixed-use overlay zone which has a side or rear lot line adjoining property in a residential zone shall have a solid masonry wall, not less than six (6) feet in height, established along said side and rear lot lines except as otherwise provided in section 11-1.66.08(1) and except where such adjoining property is used in conjunction with such commercial lot.
 - (ii) No wall shall be required if the building is located on a property line adjoining residential zones. However, windows shall not be located on the side of a commercial building which adjoins *residential zones.*
- (4) *Affordable residential unit(s).*
 - (a) This subsection applies to any proposed mixed-use project with four (4) or less residential units, when an applicant proposes to reserve a portion of the units for lower income households. In exchange for reserving affordable residential units, the applicant shall be eligible to select incentives or concessions to relieve the project of either two or three requirements listed within subsection (B)(3), as follows:
 - (i) Two (2) incentives or concessions for projects that include one (1) unit for a lower income household.
 - (ii) Three (3) incentives or concessions for projects that include at least two (2) units for lower income households, or one unit for a very low income household.
 - (b) To be eligible for the incentives or concessions, the unit(s) shall be rented at an affordable rent for lower income or very low income as defined in Health and Safety Code Section 50053(b), and shall only be rented to either lower income households, as defined in California Health and Safety Code Section 50105, or very low income households, as defined in Health and Safety Code Section

50079.5, for a minimum of thirty (30) years. Prior to the issuance of a building permit for any unit at the property or mixed-use project, the owner of the property shall execute and record on the property a deed restriction, in a form approved by the director and the city attorney, establishing legal restrictions consistent with this section.

- (c) The affordable unit(s) shall be comparable, both in size and quantity of bedrooms and bathrooms, to the largest market rate unit(s).
- (d) For proposed projects that meet the eligibility requirements set forth in this subsection, the director of community development shall ministerially grant the incentives or concessions as part of the site plan review process.”

Section 5. Severability.

If any section, subsection, subdivision, paragraph, sentence, clause or phrase of this ordinance or any part hereof is for any reason held to be invalid, such invalidity shall not affect the validity of the remaining portions of this ordinance or any part thereof. The City Council of the City of Lomita hereby declares that it would have passed each section, subsection, subdivision, paragraph, sentence, clause or phrase hereof, irrespective of the fact that any one or more sections, subsections, subdivisions, paragraphs, sentences, clauses or phrases be declared invalid.

Section 6 . Effective Date.

This ordinance shall take effect thirty (30) days after the date of its passage; and prior to fifteen (15) days after its passage, the City Clerk shall cause a copy of this ordinance to be published in accordance with the provisions of the law. The City Clerk shall certify the adoption of this ordinance.

PASSED, APPROVED AND ADOPTED, this 19th day of September 2023.

Barry Waite, Mayor

ATTEST:

Kathleen Horn Gregory, MMC, City Clerk

APPROVED AS TO FORM:

Trevor Rusin, City Attorney



CITY OF LOMITA CITY COUNCIL REPORT

TO: City Council **Item No. 7j**

FROM: Ryan Smoot, City Manager

PREPARED BY: Lina Hernandez, Senior Management Analyst

MEETING DATE: September 19, 2023

SUBJECT: Second Reading and Adoption of Ordinance No. 857 Amending LMC Title V (Sanitation and Health), Chapter 3 (Integrated Waste Management), Section 5-3.20(e), Permitting the Collection of Delinquent Solid Waste Rates on the Property Tax Rolls

RECOMMENDATION

Adopt the ordinance and find the project categorically exempt from the California Environmental Quality Act (CEQA).

BACKGROUND/ANALYSIS

On September 5, 2023, the City Council introduced Ordinance No. 857 and approved first reading of the ordinance.

As part of the negotiations with Athens Services, it was proposed to establish by separate ordinance (attached to this staff report) a process to assess non-payment on tax rolls. The proposed ordinance extends the time period of non-payment from 30 days to 60 days and stipulates that delinquent accounts may be placed on the property tax rolls for collection as set forth in Government Code section 38790.1 or other applicable law, as is common with many jurisdictions. In addition, Athens Services will be permitted to take action as is legally available to collect past due amounts from single-family or multi-family customers with cart collection service, including removing recycling carts and organic waste carts, and reducing the customer to the smallest size refuse cart. Athens may only discontinue service if doing so does not pose a health hazard and if Athens notifies the city at least five days in advance when a container will be removed, and the city will have the ability to disapprove discontinuance of service if, in the sole discretion of city, such discontinuance may pose a health hazard.

OPTIONS

- 1) Adopt Ordinance No. 857
- 2) Do not adopt the ordinance.
- 3) Provide alternate direction.

FISCAL IMPACT

None. The City of Lomita would place delinquent past due amounts on the property tax rolls on a periodic basis. Any amounts received would be remitted to Athens Services after subtracting the city's reasonable administrative costs.

ATTACHMENT

- 1) Ordinance No. 857

Reviewed by:

Gary Sugano

Gary Y. Sugano
Assistant City Manager

Approved by:

Ryan Smoot

Ryan Smoot
City Manager

Prepared by:

Lina B. Hernandez

Lina Hernandez
Senior Management Analyst

ORDINANCE NO. 857

AN ORDINANCE OF THE CITY COUNCIL OF THE CITY OF LOMITA, CALIFORNIA, AMENDING LOMITA MUNICIPAL CODE TITLE V (SANITATION AND HEALTH), CHAPTER 3 (INTEGRATED WASTE MANAGEMENT), SECTION 5-3.20(e), PERMITTING THE COLLECTION OF DELINQUENT SOLID WASTE RATES ON THE PROPERTY TAX ROLLS, AND A DETERMINATION THAT THE PROJECT IS CATEGORICALLY EXEMPT FROM THE CALIFORNIA ENVIRONMENTAL QUALITY ACT (CEQA)

THE CITY COUNCIL OF THE CITY OF LOMITA DOES HEREBY ORDAIN AS FOLLOWS:

Section 1. Environmental Review. Pursuant to Section 15061(b)(3) of the California Code of Regulations, this project is exempt from California Environmental Quality Act (CEQA) regulations. In accordance with Section 15061(b)(3) of the CEQA Guidelines, adoption of this ordinance is exempt in that it can be seen with certainty that there is no possibility that the ordinance may have a significant effect on the environment.

Section 2. Subsection (e) of Section 5-3.20 of the Lomita Municipal Code is hereby amended to read as follows:

Sec. 5-3.20. - Fees, franchises permits and licenses.

(e) Liability for fees.

(1) Each person required by this chapter to arrange for solid waste, recyclables, and organic waste collection shall be liable for the fees and charges for such collection.

(2) To protect public health, safety and well-being and to control the spread of vectors, the person responsible for day-to-day operation of each premises in the city shall make arrangements for collection, recycling and disposal of solid wastes, recyclables, and organic waste generated or accumulated on those premises in accordance with the requirements of this chapter. The fees and charges (plus any interest or penalties) shall be due and payable on the date stated on the bill. The person(s) responsible for day-to-day operation of each premises in the city at which solid waste, recyclables, and organic waste subject to this chapter is generated or accumulated shall be liable for the payment of all charges (plus any interest or penalties) for solid waste, recyclables, and organic waste services, including any recycling charges.

(3) If solid waste, recycling, and organic waste service fees and charges (and any applicable interest or penalties) are not paid within sixty (60) days of the date payment was due, the delinquencies may be placed on the property tax rolls for collection as set forth in Government Code section 38790.1 or other

applicable law. Such authority shall be in addition to other available collection remedies provided by law.

(4) Upon receipt of written notice from the person responsible for day-to-day operation of a premises in the city to discontinue solid waste, recyclables, and organic waste collection services because the person in charge of day-to-day operations has obtained a self-haul permit in accordance with section 5-3.60 of this chapter, or because the premises are vacant, the solid waste enterprise providing solid waste, recyclable, and organic waste service shall refund any advance collection fees.

Section 3. Effective Date. This ordinance shall take effect thirty (30) days after the date of its passage and adoption; and within fifteen (15) days after its passage and adoption, the City Clerk shall cause a copy of this ordinance to be published in accordance with the provisions of the law. The City Clerk shall certify the adoption of this ordinance.

PASSED, APPROVED AND ADOPTED this ____ day of _____, 2023.

ATTEST:

Barry M. Waite
Mayor

Kathleen Horn Gregory, City Clerk

APPROVED AS TO FORM:

Trevor Rusin, City Attorney



CITY OF LOMITA CITY COUNCIL REPORT

TO: City Council **Item No. 7k**

FROM: Ryan Smoot, City Manager

PREPARED BY: Lina Hernandez, Senior Management Analyst

MEETING DATE: September 19, 2023

SUBJECT: Professional Services Agreement with Fairbank, Maslin, Maullin, Metz & Associates (FM3) to Conduct a Community Survey

RECOMMENDATION

Authorize the City Manager to execute a Professional Services Agreement with Fairbank, Maslin, Maullin, Metz & Associates (FM3) in an amount not to exceed \$40,000.

BACKGROUND

In 2018, FM3 was selected to conduct a community for the City to assist in the development of goals and objectives for the community and the organization. The results of the survey were presented to the City Council and have since assisted staff in the preparation of budget priorities and proposed work plans.

In 2019, FM3 conducted an updated survey in preparation for the City's strategic plan and goals workshop to further assess the priorities, desires, and concerns of the community to ensure that the City's goals and budget priorities most accurately reflect those of our residents.

DISCUSSION

Based on FM3's unique understanding of the City and its needs, FM3 was asked for an updated proposal and cost estimate to perform a follow-up survey. Based on this proposal (attached to this report as Exhibit A), staff is recommending approval of a professional services agreement with FM3 to conduct a survey to update our data concerning residents' priorities and satisfaction and preparation for upcoming budget.

Similar to previous surveys, FM3's approach will include an approximately 15-minute survey, featuring between 45-55 unique questions. The survey will be multi modal –

both by phone and online, and will be available in English and in Spanish. FM3's proposal is comprehensive, and includes all costs for questionnaire design, Spanish translation, sample acquisition and preparation, programming, email invitations, survey hosting, multilingual telephone interviewing, data entry and analysis, and reporting. After execution of the survey, FM3 will complete an analysis of the results and present the findings to the City.

OPTIONS:

1. Authorize the City Manager to execute the agreement.
2. Do not authorize the City Manager to execute the agreement.
3. Give staff alternative direction.

FISCAL IMPACT

The proposed agreement is for an amount not to exceed \$40,000. This project will be paid for from the City Manager Contractual Services account.

ATTACHMENTS

1. Professional Services Agreement with Proposal (Exhibit A)

Approved by:



Gary Y. Sugano
Assistant City Manager



Ryan Smoot
City Manager

Prepared by:



Lina Hernandez
Senior Management Analyst



**CONTRACT FOR PROFESSIONAL SERVICES
BETWEEN
THE CITY OF LOMITA AND
FAIRBANK, MASLIN, MAULLIN, METZ & ASSOCIATES (FM3)**

This AGREEMENT to conduct a City of Lomita resident satisfaction and budget priorities survey is entered into this 19th day of September 2023, by and between the CITY OF LOMITA, a general law city and municipal corporation ("CITY") and Fairbank, Maslin, Maullin, Metz & Associates (FM3) a California corporation ("CONSULTANT").

RECITALS

- A. CITY does not have the personnel able and/or available to perform the services required under this agreement.
- B. Therefore, CITY desires to contract out for consulting services for design, conducting, and analysis of a community survey.
- C. CONSULTANT warrants to CITY that it has the qualifications, experience and facilities to perform properly and timely the services under this Agreement.
- D. CITY desires to contract with CONTRACTOR to perform the services as described in **Exhibit A** of this Agreement.

NOW, THEREFORE, based on the foregoing recitals, CITY and CONSUTANT agree as follows:

1. CONSIDERATION AND COMPENSATION.

- A. As partial consideration, CONSULTANT agrees to perform the work listed in the SCOPE OF SERVICES, attached as **Exhibit A**;
- B. As an additional consideration, CONTRACTOR and CITY agree to abide by the terms and conditions contained in this Agreement.
- C. As additional consideration, CITY agrees to pay CONTRACTOR an amount not to exceed \$40,000 the CONSULTANT'S estimated costs of its services, unless otherwise specified by written amendment to this Agreement.
- D. No additional compensation shall be paid for any other expenses incurred, unless first approved by the City Manager or his designee.

E. CONSULTANT shall submit to CITY, by not later than the 10th day of each month, its bill for services itemizing the fees and costs incurred during the previous month. CITY shall pay CONSULTANT'S all uncontested amounts set forth in the CONTRACTOR'S bill within 30 days after it is received.

2. **SCOPE OF SERVICES.**

A. CONSULTANT will perform the services and activities set forth in the SCOPE OF SERVICES attached hereto as **Exhibit A** and incorporated herein by this reference. If any part of **Exhibit A** is inconsistent with the terms of this Agreement, the terms of this Agreement shall control.

B. Except as herein otherwise expressly specified to be furnished by CITY, CONTRACTOR will, in a professional manner, furnish all the labor, technical, administrative, professional and other personnel, all supplies and materials, equipment, printing, vehicles, transportation, office space, and facilities necessary or proper to perform and complete the work and provide the professional services required of CONTRACTOR by this Agreement.

3. **PAYMENTS.** For CITY to pay CONTRACTOR as specified by this Agreement, CONTRACTOR must submit an invoice to CITY which lists the reimbursable costs, the specific tasks performed, and, for work that includes deliverables, the percentage of the task completed during the billing period.

4. **TIME OF PERFORMANCE.** The services of CONTRACTOR are to commence upon receipt of a notice to proceed from CITY and shall continue until all authorized work is completed to CITY's reasonable satisfaction, in accordance with the schedule incorporated in "**Exhibit A**," unless extended in writing by CITY.

5. **FAMILIARITY WITH WORK.** By executing this Agreement, CONTRACTOR represents that CONSULTANT has (a) thoroughly investigated and considered the scope of services to be performed; (b) carefully considered how the services should be performed; and (c) understands the facilities, difficulties, and restrictions attending performance of the services under this Agreement.

6. **KEY PERSONNEL.** CONSULTANT's key person assigned to perform work under this Agreement is Richard Bernard. CONTRACTOR shall not assign another person to be in charge of the work contemplated by this Agreement without the prior written authorization of CITY.

7. **TERM OF AGREEMENT.** The term of this Agreement shall commence upon execution by both parties and shall expire on September 20, 2024 unless earlier termination occurs under Section 13 of this Agreement or extended in writing in advance by both parties.

8. **CHANGES.** CITY may order changes in the services within the general scope of this Agreement, consisting of additions, deletions, or other revisions, and the contract sum, and the contract time will be adjusted accordingly. All such changes must be

authorized in writing, executed by CONSULTANT and CITY. The cost or credit to CITY resulting from changes in the services will be determined in accordance with the written agreement between the parties.

9. **TAXPAYER IDENTIFICATION NUMBER.** CONSULTANT will provide CITY with a Taxpayer Identification Number.

10. **PERMITS AND LICENSES.** CONSULTANT will obtain and maintain during the term of this Agreement all permits, licenses, and certificates that may be required by local, state, and federal laws in connection with the performance of services under this Agreement, including a business license as specified in Title VI, Chapter 2 of the Lomita Municipal Code.

11. **TERMINATION.**

A. Except as otherwise provided, CITY may terminate this Agreement at any time with or without cause. Notice of termination shall be in writing.

B. CONSULTANT may terminate this Agreement. Notice will be in writing at least 30 days before the effective termination date.

C. In the event of such termination, CONSULTANT shall cease services as of the date of termination, all finished or unfinished documents, data, drawings, maps, and other materials prepared by CONSULTANT shall, at CITY's option, become CITY's property, and CONSULTANT will receive just and equitable compensation for any work satisfactorily completed up to the effective date of notice of termination.

D. Should the Agreement be terminated pursuant to this Section, CITY may procure on its own terms services similar to those terminated.

12. **INDEMNIFICATION.**

A. CONSULTANT shall indemnify, defend with counsel approved by CITY, and hold harmless CITY, its officers, officials, employees and volunteers from and against all liability, loss, damage, expense, cost (including without limitation reasonable attorneys fees, expert fees and all other costs and fees of litigation) of every nature arising out of or in connection with CONSULTANT'S performance of work hereunder or its failure to comply with any of its obligations contained in this AGREEMENT, regardless of CITY'S passive negligence, but excepting such loss or damage which is caused by the sole active negligence or willful misconduct of CITY. Should CITY in its sole discretion find CONSULTANT'S legal counsel unacceptable, then CONSULTANT shall reimburse CITY its costs of defense, including without limitation reasonable attorneys fees, expert fees and all other costs and fees of litigation. CONSULTANT shall promptly pay any final judgment rendered against CITY (and its officers, officials, employees and volunteers) covered by this indemnity obligation. It is expressly understood and agreed that the foregoing provisions are intended to be as broad and inclusive as is permitted by the law of the State

of California and will survive termination of this Agreement.

- B. The requirements as to the types and limits of insurance coverage to be maintained by CONSULTANT as required by Section 19, and any approval of said insurance by CITY, are not intended to and will not in any manner limit or qualify the liabilities and obligations otherwise assumed by CONSULTANT pursuant to this Agreement, including, without limitation, to the provisions concerning indemnification.
13. **ASSIGNABILITY.** This Agreement is for CONSULTANT's professional services. CONSULTANT's attempts to assign the benefits or burdens of this Agreement without CITY's written approval are prohibited and will be null and void.
14. **INDEPENDENT CONTRACTOR.** CITY and CONSULTANT agree that THE CONSULTANT will act as an independent contractor and will have control of all work and the manner in which it is performed. THE CONSULTANT will be free to contract for similar service to be performed for other employees while under contract with CITY. CONSULTANT is not an agent or employee of CITY and is not entitled to participate in any pension plan, insurance, bonus or similar benefits CITY provides for its employees. Any provision in this Agreement that may appear to give CITY the right to direct CONSULTANT as to the details of doing the work or to exercise a measure of control over the work means that CONSULTANT will follow the direction of the CITY as to end results of the work only.
15. **AUDIT OF RECORDS.**
- A. THE CONSULTANT agrees that CITY, or designee, has the right to review, obtain, and copy all records pertaining to the performance of this Agreement. CONSULTANT agrees to provide CITY, or designee, with any relevant information requested and will permit CITY, or designee, access to its premises, upon reasonable notice, during normal business hours for the purpose of interviewing employees and inspecting and copying such books, records, accounts, and other material that may be relevant to a matter under investigation for the purpose of determining compliance with this Agreement. CONSULTANT further agrees to maintain such records for a period of three (3) years following final payment under this Agreement.
- B. CONSULTANT will keep all books, records, accounts and documents pertaining to this Agreement separate from other activities unrelated to this Agreement.
16. **CORRECTIVE MEASURES.** CONSULTANT will promptly implement any corrective measures required by CITY regarding the requirements and obligations of this Agreement. CONSULTANT will be given a reasonable amount of time as determined by CITY to implement said corrective measures. Failure of CONSULTANT to implement required corrective measures shall result in immediate termination of this Agreement.

17. INSURANCE REQUIREMENTS.

- A. CONSULTANT, at CONSULTANT's own cost and expense, shall procure and maintain, for the duration of the contract, the following insurance policies:
1. Workers Compensation Insurance as required by law. CONSULTANT shall require all subcontractors similarly to provide such compensation insurance for their respective employees. Any notice of cancellation or non-renewal of all Workers' Compensation policies must be received by CITY at least thirty (30) days prior to such change. The insurer shall agree to waive all rights of subrogation against CITY, its officers, agents, employees, and volunteers for losses arising from work performed by CONSULTANT for CITY.
 2. General Liability Coverage. CONSULTANT shall maintain commercial general liability insurance in an amount of not less than one million dollars (\$1,000,000) per occurrence for bodily injury, personal injury, and property damage. If a commercial general liability insurance form or other form with a general aggregate limit is used, either the general aggregate limit shall apply separately to the work to be performed under this Agreement or the general aggregate limit shall be at least twice the required occurrence limit.
 3. Automobile Liability Coverage. CONSULTANT shall maintain automobile liability insurance covering bodily injury and property damage for all activities of CONTRACTOR arising out of or in connection with the work to be performed under this Agreement, including coverage for owned, hired, and non-owned vehicles, in an amount of not less than one million dollars (\$1,000,000) combined single limit for each occurrence.
 4. Professional Liability Coverage. CONSULTANT shall maintain professional errors and omissions liability insurance for protection against claims alleging negligent acts, errors, or omissions which may arise from CONSULTANT'S operations under this Agreement, whether such operations be by CONSULTANT or by its employees, subcontractors, or subcontractors. The amount of this insurance shall not be less than one million dollars (\$1,000,000) on a claims-made annual aggregate basis, or a combined single-limit-per-occurrence basis. When coverage is provided on a "claims made basis," CONSULTANT will continue to renew the insurance for a period of three (3) years after this Agreement expires or is terminated. Such insurance will have the same coverage and limits as the policy that was in effect during the term of this Agreement and will cover CONSULTANT for all claims made by CITY arising out of any errors or omissions of CONSULTANT, or its officers, employees or agents during the time this Agreement was in effect.
- B. Endorsements. Each general liability, automobile liability and professional liability insurance policy shall be issued by a financially responsible insurance company or companies admitted and authorized to do business in the State of

California, or which is approved in writing by CITY, and shall be endorsed as follows. CONSULTANT also agrees to require all contractors, and subcontractors to do likewise.

1. "The CITY, its elected or appointed officers, officials, employees, agents, and volunteers are to be covered as additional insureds with respect to liability arising out of work performed by or on behalf of the CONSULTANT, including materials, parts, or equipment furnished in connection with such work or operations."
 2. This policy shall be considered primary insurance as respects CITY, its elected or appointed officers, officials, employees, agents, and volunteers. Any insurance maintained by CITY, including any self-insured retention CITY may have, shall be considered excess insurance only and shall not contribute with this policy.
 3. This insurance shall act for each insured and additional insured as though a separate policy had been written for each, except with respect to the limits of liability of the insuring company.
 4. The insurer waives all rights of subrogation against CITY, its elected or appointed officers, officials, employees, or agents.
 5. Any failure to comply with reporting provisions of the policies shall not affect coverage provided to CITY, its elected or appointed officers, officials, employees, agents, or volunteers.
 6. The insurance provided by this policy shall not be suspended, voided, canceled, or reduced in coverage or in limits except after thirty (30) days' written notice has been received by CITY.
- C. CONSULTANT agrees to provide immediate notice to CITY of any claim or loss against Contractor arising out of the work performed under this agreement. CITY assumes no obligation or liability by such notice, but has the right (but not the duty) to monitor the handling of any such claim or claims if they are likely to involve CITY.
- D. Any deductibles or self-insured retentions must be declared to and approved by CITY. At CITY's option, CONTRACTOR shall demonstrate financial capability for payment of such deductibles or self-insured retentions.
- E. CONSULTANT shall provide certificates of insurance with original endorsements to CITY as evidence of the insurance coverage required herein. Certificates of such insurance shall be filed with CITY on or before commencement of performance of this Agreement. Current certification of insurance shall be kept on file with CITY at all times during the term of this Agreement.

- F. Failure on the part of CONSULTANT to procure or maintain the required insurance shall constitute a material breach of contract under which CITY may terminate this Agreement pursuant to Section 13 above.
- G. The commercial general and automobile liability policies required by this Agreement shall allow CITY, as additional insured, to satisfy the self-insured retention (“SIR”) and/or deductible of the policy in lieu of the CONSULTANT (as the named insured) should CONSULTANT fail to pay the SIR or deductible requirements. The amount of the SIR or deductible shall be subject to the approval of the City Attorney and the Finance Director. CONSULTANT understands and agrees that satisfaction of this requirement is an express condition precedent to the effectiveness of this Agreement. Failure by CONSULTANT as primary insured to pay its SIR or deductible constitutes a material breach of this Agreement. Should CITY pay the SIR or deductible on CONSULTANT’S behalf upon CONSULTANT’S failure or refusal to do so to secure defense and indemnification as an additional insured under the policy, CITY may include such amounts as damages in any action against Contractor for breach of this Agreement in addition to any other damages incurred by CITY due to the breach.
18. **USE OF OTHER CONTRACTORS.** THE CONSULTANT must obtain CITY’s prior written approval to use any Contractors while performing any portion of this Agreement. Such approval must include approval of the proposed Contractor and the terms of compensation.
19. **FINAL PAYMENT ACCEPTANCE CONSTITUTES RELEASE.** The acceptance by the CONSULTANT of the final payment made under this Agreement shall operate as and be a release of CITY from all claims and liabilities for compensation to the CONSULTANT for anything done, furnished or relating to the CONSULTANT’S work or services. Acceptance of payment shall be any negotiation of CITY’S check or the failure to make a written extra compensation claim within ten (10) calendar days of the receipt of that check. However, approval or payment by CITY shall not constitute, nor be deemed, a release of the responsibility and liability of CONSULTANT, its employees, sub-Contractors and agents for the accuracy and competency of the information provided and/or work performed; nor shall such approval or payment be deemed to be an assumption of such responsibility or liability by CITY for any defect or error in the work prepared by CONSULTANT, its employees, sub-Contractors and agents.
20. **CORRECTIONS.** In addition to the above indemnification obligations, the CONSULTANT shall correct, at its expense, all errors in the work which may be disclosed during the CITY’S review of CONTRACTOR’S report or plans. Should the CONSULTANT fail to make such correction in a reasonably timely manner, such correction shall be made by CITY, and the cost thereof shall be charged to CONSULTANT. In addition to all other available remedies, CITY may deduct the cost of such correction from any retention amount held by CITY or may withhold payment otherwise owed CONSULTANT under this Agreement up to the amount of the cost of correction.

21. **NON-APPROPRIATION OF FUNDS.** Payments to be made to CONSULTANT by CITY for services preformed within the current fiscal year are within the current fiscal budget and within an available, unexhausted fund. In the event that CITY does not appropriate sufficient funds for payment of CONSULTANT’S services beyond the current fiscal year, the Agreement shall cover payment for CONSULTANT’S only to the conclusion of the last fiscal year in which CITY appropriates sufficient funds and shall automatically terminate at the conclusion of such fiscal year.
22. **NOTICES.** All communications to either party by the other party will be deemed made when received by such party at its respective name and address as follows:

CITY	CONTRACTOR
<u>City of Lomita</u> <u>24300 Narbonne Avenue</u> <u>Lomita, CA 90717</u> <u>ATTN: City Manager</u>	Fairbank, Maslin, Maullin, Metz & Associates (FM3) 12100 Wilshire Boulevard, Suite 350 Los Angeles, CA 90025 <u>ATTN: Richard Bernard, Partner</u>

Any such written communications by mail will be conclusively deemed to have been received by the addressee upon deposit thereof in the United States Mail, postage prepaid and properly addressed as noted above. In all other instances, notices will be deemed given at the time of actual delivery. Changes may be made in the names or addresses of persons to whom notices are to be given by giving notice in the manner prescribed in this paragraph. Courtesy copies of notices may be sent via electronic mail, provided that the original notice is deposited in the U.S. mail or personally delivered as specified in this Section.

23. **SOLICITATION.** CONSULTANT maintains and warrants that it has not employed nor retained any company or person, other than CONSULTANT’s bona fide employee, to solicit or secure this Agreement. Further, CONSULTANT warrants that it has not paid, nor has it agreed to pay any company or person, other than CONSULTANT’s bona fide employee, any fee, commission, percentage, brokerage fee, gift or other consideration contingent upon or resulting from the award or making of this Agreement. Should CONSULTANT breach or violate this warranty, CITY may rescind this Agreement without liability.
24. **THIRD PARTY BENEFICIARIES.** This Agreement and every provision herein is generally for the exclusive benefit of CONSULTANT and CITY and not for the benefit of any other party. There will be no incidental or other beneficiaries of any of the CONSULTANT’s or CITY’s obligations under this Agreement.

25. **INTERPRETATION.** This Agreement was drafted in and will be construed in accordance with the laws of the State of California, and exclusive venue for any action involving this agreement will be in Los Angeles County.
26. **ENTIRE AGREEMENT.** This Agreement, and its Attachments, sets forth the entire understanding of the parties. There are no other understandings, terms or other agreements expressed or implied, oral or written.
27. **RULES OF CONSTRUCTION.** Each Party had the opportunity to independently review this Agreement with legal counsel. Accordingly, this Agreement will be construed simply, as a whole, and in accordance with its fair meaning; it will not be interpreted strictly for or against either Party.
28. **AUTHORITY/MODIFICATION.** The Parties represent and warrant that all necessary action has been taken by the Parties to authorize the undersigned to execute this Agreement and to engage in the actions described herein. This Agreement may be modified by written amendment with signatures of all parties to this Agreement. CITY's city administrator, or designee, may execute any such amendment on behalf of CITY.
29. **ACCEPTANCE OF FACSIMILE OR ELECTRONIC SIGNATURES.** The Parties agree that this Agreement will be considered signed when the signature of a party is delivered by facsimile transmission, scanned and delivered via electronic mail, or delivered using digital signature technology approved by CITY. Such facsimile or electronic signatures will be treated in all respects as having the same effect as an original signature.
30. **FORCE MAJEURE.** Should performance of this Agreement be impossible due to fire, flood, explosion, war, embargo, government action, civil or military authority, the natural elements, or other similar causes beyond the Parties' control, then the Agreement will immediately terminate without obligation of either party to the other.
31. **TIME IS OF ESSENCE.** Time is of the essence to comply with dates and schedules to be provided.
32. **ATTORNEY'S FEES.** The parties hereto acknowledge and agree that each will bear his or its own costs, expenses and attorneys' fees arising out of and/or connected with the negotiation, drafting and execution of the Agreement, and all matters arising out of or connected therewith except that, in the event any action is brought by any party hereto to enforce this Agreement, the prevailing party in such action shall be entitled to reasonable attorneys' fees and costs in addition to all other relief to which that party or those parties may be entitled.
33. **STATEMENT OF EXPERIENCE.** By executing this Agreement, CONSULTANT represents that it has demonstrated trustworthiness and possesses the quality, fitness and capacity to perform the Agreement in a manner satisfactory to CITY. CONSULTANT represents that its financial resources, surety and insurance experience, service experience, completion ability, personnel, current workload,

experience in dealing with private Contractors, and experience in dealing with public agencies all suggest that CONSULTANT is capable of performing the proposed contract and has a demonstrated capacity to deal fairly and effectively with and to satisfy a public agency.

34. DISCLOSURE REQUIRED. (CITY and CONSULTANT initials required at one of the following paragraphs)

By their respective initials next to this paragraph, CITY and CONTRACTOR hereby acknowledge that CONSUTLANT is a “CONSULTANT” for the purposes of the California Political Reform Act because CONSULTANT’S duties would require him or her to make one or more of the governmental decisions set forth in Fair Political Practices Commission Regulation 18700.3(a)(2) or otherwise serves in a staff capacity for which disclosure would otherwise be required were CONSULTANT employed by CITY. CONSULTANT hereby acknowledges his or her assuming-office, annual, and leaving-office financial reporting obligations under the California Political Reform Act and the CITY’S Conflict of Interest Code and agrees to comply with those obligations at his or her expense. Prior to the Contractor commencing services hereunder, the City’s Manager shall prepare and deliver to CONSULTANT a memorandum detailing the extent of CONSULTANT’S disclosure obligations in accordance with the CITY’S Conflict of Interest Code.

City Initials _____

Contractor Initials _____

OR

By their initials next to this paragraph, CITY and CONSULTANT hereby acknowledge that CONSULTANT is not a “CONSULTANT” for the purpose of the California Political Reform Act because CONSULTANT’S duties and responsibilities are not within the scope of the definition of contractor in Fair Political Practice Commission Regulation 18700.3(a)(2) and is otherwise not serving in staff capacity in accordance with CITY’S Conflict of Interest Code.

City Initials _____

Contractor Initials _____

[signatures on following page]

IN WITNESS WHEREOF the parties hereto have executed this contract the day and year first hereinabove written.

CITY OF LOMITA

CONTRACTOR

Ryan Smoot, City Manager

By:

Richard Bernard, Partner

ATTEST:

Kathleen Horn Gregory, City Clerk

Taxpayer ID No.

APPROVED AS TO FORM:

Trevor Rusin, City Attorney



TO Ryan Smoot, City Manager
City of Lomita

FROM Richard Bernard Ph.D. and Maya Gutierrez
FM3 Research

RE: Proposal to Conduct a City of Lomita Resident Satisfaction and Budget Priorities Survey

DATE September 12, 2023

Fairbank, Maslin, Maullin, Metz & Associates (FM3) is pleased to continue working with the City and to submit this proposal to conduct a resident satisfaction and budget priorities survey for the City of Lomita. The purpose of this study is to identify residents' overall opinions and impressions of the City of Lomita and their services and identify residents' budgeting priorities. FM3 will draft new questions relevant to City residents in 2023, as well as track previously asked questions from the 2018 resident survey, to see if awareness and/or attitudes are consistent or have changed over time.

PROPOSED RESEARCH SPECIFICATIONS

As was the case in the previous 2018 Resident Satisfaction survey, FM3 recommends conducting a dual-mode survey offered online and by telephone among a randomized sample of 400 adult residents in the City of Lomita. FM3 proposes to again contact residents via e-mail, text, telephone and postcard. The postcard invitation will be mailed to a random number of households in the City for which no contact e-mail address or telephone number is available. If we collect more than 400 resident surveys, they will be included at no additional cost to the City. The survey will feature an average interview length of 15 minutes. Such a survey length will allow for approximately 45-55 unique questions (including demographic and battery questions). FM3 will offer the survey in English and Spanish.

Detailed scope of work specifications and costs for the proposed research are provided below; we look forward to working with the City on this important project.

Research	Dual-mode address-based survey
Methodology	
Data Collection	Telephone and online interviews
Mode	

Respondent Telephone calls, text messaging, email invitations, and postcards
Contact Method
Sample 400 City of Lomita residents
Margin of ±4.9 percent in 95 out of 100 cases for a sample of 400 interviews
Sampling Error

Questionnaire 15-minute survey, featuring between 45-55 unique questions (including battery question items)

Language Telephone and online interviews will be conducted in English and Spanish.

Deliverables Following the completion of the survey, we will provide:

- Final survey questionnaire
- Topline survey results
- Verbatim answers to any open-ended questions (if applicable)
- PowerPoint presentation (including key findings, results, conclusions, and actionable recommendations)
- Presentation of results to staff, board members, or other stakeholders (if requested; in person if desired)

Cost FM3 will also be available for ongoing consultation and any further analysis of the research. FM3 is prepared to conduct a dual-mode survey (online and by telephone) among 400 City of Lomita residents for a not-to-exceed amount of \$40,000. These prices are comprehensive, and include all costs for questionnaire design, Spanish translation, sample acquisition and preparation, programming, email invitations, postcards, online survey hosting in English and Spanish, bilingual telephone interviewing, data entry and analysis, and reporting.

We would welcome the opportunity to work with you on this research and we are prepared to start. If you have any questions or if there is any further information we can provide, please do not hesitate to contact us. Thank you for your consideration; our contact information is as follows:

Richard Bernard, Ph.D., Partner

Fairbank, Maslin, Maullin, Metz & Associates (FM3)
12100 Wilshire Boulevard, Suite 350
Los Angeles, CA 90025
(310) 428-1809 (cell)
Bernard@FM3Research.com

Maya Gutierrez, Researcher

Fairbank, Maslin, Maullin, Metz & Associates (FM3)
12100 Wilshire Boulevard, Suite 350
Los Angeles, CA 90025
(661) 709-1845 (cell)
Gutierrez@FM3Research.com



CITY OF LOMITA CITY COUNCIL REPORT

TO: City Council **Item No. 8a**

FROM: Ryan Smoot, City Manager

PREPARED BY: Brianna Rindge, Community & Economic Development Director

MEETING DATE: September 19, 2023

SUBJECT: Discussion and Consideration of the Sunstone Economic Development Challenge at USC Price

RECOMMENDATION

Receive and file.

DISCUSSION

The University of Southern California (USC) Sol Price School of Public Policy established the Sunstone Economic Development Challenge in 2022 in partnership with the USC City/County Management Fellowship through a grant from Sunstone Management, a private capital firm in Southern California that invests in diverse, early-stage technology entrepreneurs. The challenge, now in its second year, serves as a charitable program designed to help local governments develop and implement strategies to attract and support early-stage startup businesses, raise private capital, and create jobs in their communities.

The program proved a success for its first year client cities, El Segundo, Irvine, Garden Grove, and Long Beach. The winning team worked with the City of Garden Grove to develop a proposal to use existing workforce development assets with online recruitment and training, fund reallocation for marketing, and a hospitality industry-wide job fair to address the need for more hospitality workers in all areas. The team also recommended a plan to partner with high school and community college hospitality programs and attracting a satellite campus of the Los Angeles Hospitality Training Academy also should be considered.

Participation in this public-private educational partnership incurs no direct cost to the City and in fact augments the City's economic development efforts. The expectations of each client city are as follows.

1. Team selection in December 2024
2. Two meetings with the student team in spring 2024
3. City Hall tour for the student team in March 2024
4. Attendance at Challenge's final pitch event in April 2024
5. Student team final pitch presentation to City Council in May 2024

Community and Economic Development Director Brianna Rindge worked with USC staff to land Lomita on the client cities list for the Challenge's second season and will manage the program for the City. More details are available in Attachment 1 to this report.

OPTIONS

None. Information only. Receive and file.

ATTACHMENT

1. Complete Challenge details

Reviewed by:



Gary Y. Sugano
Assistant City Manager

Approved by:



Ryan Smoot
City Manager

Prepared by:



Brianna Rindge
Community & Economic Development Director

LETTER OF INTENT (LOI)

For supporting the USC City/County Management Fellowship Program:

SUNSTONE ECONOMIC DEVELOPMENT CHALLENGE @ USC PRICE

Updated: August 29th, 2023

BACKGROUND

The [Sunstone Economic Development Challenge](#) @ USC Price is an initiative aimed at empowering local governments to create and implement inclusive strategies to support and grow early-stage technology startups and high-tech jobs in their communities. It is a partnership between the [USC City/County Management Fellowship Program](#), [USC Sol Price School of Public Policy](#), and [Sunstone Management, Inc.](#) The Sunstone Economic Development Challenge @ USC Price is supported by a five-year grant gifted by the [Sunstone Community Fund](#). Teams of university students, in collaboration with local government clients, will develop forward-thinking and feasible strategies to attract and support startups, raise private capital, and create jobs. Final projects will be presented to a panel of judges and the winning team will be announced at an award ceremony in mid-April 2023.

VISION, MISSION & OBJECTIVES

Our collective vision is to further economic development in client cities, and our mission is to provide students opportunities to attract, retain, and grow early-stage technology businesses in their chosen community and to engage with industry leaders and professionals in their chosen field. To achieve this vision and mission, we have established the following objectives:

- 1. Business Attraction** – create innovative strategies for cities and counties to attract and retain early-stage entrepreneurs to grow businesses and jobs in their communities.
- 2. Capital Access** – create innovative strategies for cities and counties to attract and grow private sector capital investment and provide capital access to early-stage entrepreneurs in their communities.
- 3. Technical Assistance** – create public-private partnerships that provide technical assistance and support to early-stage entrepreneurs (e.g., incubators, accelerators, innovation hubs).
- 4. University Partnerships** – build innovative partnerships between cities and universities or colleges to cultivate entrepreneurship and retain entrepreneurs in their cities or counties following graduation.
- 5. Social Impact** – develop greater impact on addressing diversity, equity, inclusion or environmental, social and governance categories.

RESPONSIBILITIES

A coalition of public, private, and non-profit sector partners is required to achieve our vision, mission, and objectives on behalf of stakeholders involved in the Sunstone Economic Development Challenge @ USC Price. Therefore, specific responsibilities of each partner are presented below:

- **USC City/County Management Fellowship Program (CMF).** The CMF will be responsible for hosting the information sessions, coordinating the student registration and team selection, and managing the speaker series and the *CMF Summit & Sunstone Challenge Final Pitch*.
- **Client Cities.** Client cities agree to review all the student proposals for their city and choose one (1) team to be their consultants in December 2023. Client cities also agree to participate in two (2) meetings with the student team regarding community and economic development plans and challenges for their communities as follows: (i) virtual meeting in February 2024, and (ii) in-person meeting/city hall tour in March 2024, with a total duration of no more than three hours.

Additionally, client cities will appoint a designated point of contact from the client city to ensure clear and effective communication with the student team and the program leads throughout the challenge and commit to attending the final challenge event. Student teams will present their pitch to City staff, City Council, Council Committee, or Advisory Commission.

Lastly, client cities will indicate their agreement by executing the non-binding Letter of Intent as a demonstration of commitment and agreement to the terms outlined.

- **Sunstone Management.** Sunstone Management will be responsible for being the liaison between the CMF and client cities for the Sunstone Economic Development Challenge @ USC Price. Sunstone Management will also identify speakers for the speaker series and provide administrative services to support the Challenge’s activities. Finally, Sunstone Management will be responsible for coordinating grant funding from the Sunstone Community Fund to support the Sunstone Economic Development Challenge @ USC Price over the 5-year period.

PROJECT TIMELINE

The Letter of Intent is the first step to establishing the Sunstone Economic Development Challenge @ USC Price. The following Actions & Timeline is for illustrative purposes only and may change.

Actions & Timeline

• Letter of Intent Executed	September 2023
• Public Announcements	September 2023
• Speaker Series #1: Government Proposal Process	October 2023
• Speaker Series #2: Capital Access & Economic Development	November 2023
• Proposal Deadline	December 2023
• Client Cities Pick Top Proposals	December 2023
• Student Teams Begin Pitches	January 2024
• Virtual Meeting with Student Team	February 2024
• Speaker Series #3: Policy Analysis, Research, and Writing	February 2024
• In-Person Meeting/City Hall Tour with Student Team	March 2023
• Speaker Series #4: Business Attraction Strategies & PPPs	March 2023
• USC CMF Summit & Sunstone Challenge Final Pitch	April 2024
• Student Teams Present to Client City Staff/Council/Commission	April 2024
• Staff Memos and Presentations Given to Client Cities	May 2024



CITY OF LOMITA CITY COUNCIL REPORT

TO: City Council **Item No. Sch 8b**

FROM: Ryan Smoot, City Manager

REVIEWED BY: Carla Dillon, P.E., Public Works Director

MEETING DATE: September 19, 2023

SUBJECT: Discussion and Consideration to Authorize the Release of a Bid Package for the 247th Street Area Water Main Replacement Project

RECOMMENDATIONS

Authorize staff to release the bid package for the 247th Street Area Water Main Replacement Project; and find the project categorically exempt from CEQA.

BACKGROUND

The 247th Street Area Water Main Replacement Project consists of replacing pipelines. The existing water main around 247th Street area runs north and south within private properties crossing 246th Street, 247th Street, 247th Place, and 248th Street. This existing water main includes a 4-inch diameter pipe for approximately 955 feet and a 6-inch diameter pipe for the rest of the area. The water mains were constructed in 1928 and have exceeded their useful life. The age of these water mains makes them particularly at risk for main breaks and leaks, especially as a result of an earthquake.

The proposed new water main will extend from 246th Street beyond the City boundaries, looping within the City of Los Angeles right-of-way and along Western Avenue (which is Caltrans right-of-way), and connecting back to the City of Lomita along 247th Street, 247th Place, 248th Street and Lomita Blvd. This project consists of constructing approximately 3,300 linear feet of 6-inch PVC water pipeline and appurtenances (fire hydrants, valves, services, and fittings). The existing pipeline located in private property will be abandoned.

This project aims to improve fire flow in the project area by replacing the existing 4-inch and 6-inch diameter pipes, which allows emergency responders to more effectively fight fires in this area. This project will also reduce the risk of water damage to private properties in the event of a main break or earthquake.

In November 2021, the City Council awarded a Professional Services Agreement to

Onward Engineering for engineering design services in the amount of \$133,119.50 plus a 20% contingency in the amount of \$26,623.90. The design phase encountered several delays due to approvals by outside parties (CalTrans and City of Los Angeles), as well as the identification of unmarked utilities during the potholing. The design of the water main replacement is completed, and the project is ready to be released for bid.

Staff is requesting approval of the project and authorization to release it for bid as soon as possible.

CEQA

It is recommended that the City Council find this project is not subject to CEQA pursuant to CEQA Guidelines, Section 15302 Replacement or Reconstruction of existing structures and facilities. This project installation can be found to be exempt from the requirements of CEQA. The proposed project consists of replacement pipes to supply water to residences with no increase in capacity.

FISCAL IMPACT

There is no fiscal impact of this action.

The City has Hazard Mitigation Grant Program (HMGP) funds for the 247th Street Area Water Main Replacement project which provides for the \$1,125,000 in funding toward the project. The City is required to contribute at least 25% of the total project cost.

OPTIONS

1. Approve staff's recommendation.
2. Provide alternative direction.

ATTACHMENTS

1. Design Plans and Bid Documents
2. CEQA Notice of Exemption

Reviewed by:



Gary Y. Sugano
Assistant City Manager

Approved by:



Ryan Smoot
City Manager

Reviewed by:



Carla Dillon, P.E.
Public Works Director

WATER MAIN REPLACEMENT 247TH STREET AREA PROJECT NO. 2021-1-WA

UTILITY CONTACTS

CONTRACTOR SHALL NOTIFY ALL UTILITY AGENCIES CONCERNED A MINIMUM OF 48 HOURS PRIOR TO CONSTRUCTION INCLUDING BUT NOT LIMITED TO:

AT&T	(510) 645-2929
CALTRANS	(213) 897-0954
CHARTER	(714) 591-4870
CITY OF LOMITA	(310) 325-7110
CITY OF LOMITA- WATER DIVISION (EMERGENCY PHONE)	(310) 597-6428
LOS ANGELES COUNTY FIRE DEPARTMENT	(310) 326-2461
LOS ANGELES COUNTY SHERIFF DEPARTMENT	(310) 539-1661
LOS ANGELES COUNTY SANITATION DISTRICT	(562) 699-7411
LOS ANGELES COUNTY FLOOD CONTROL DISTRICT	(562) 861-0316
SOUTHERN CALIFORNIA EDISON	(714) 796-9932
SOUTHERN CALIFORNIA GAS	(310) 687-2032
TIME WARNER CABLE	(714) 903-8446
UNDERGROUND SERVICE ALERT	811
VERIZON	(469) 896-4238

CITY STANDARD PLANS

- W-100: WATER MAIN TRENCH DETAIL
- W-101: 1" WATER SERVICE INSTALLATION
- W-102: 2" WATER SERVICE INSTALLATION
- W-103: 1" & 2" SERVICE CONNECTION TO MAIN LINE
- W-110: FIRE HYDRANT INSTALLATION
- W-130: DI CONNECTION TO MAIN
- W-140: CONCRETE THRUST BLOCK (4" TO 16" DIA FITTING)
- W-142: THRUST BLOCK AREA REQUIREMENTS
- W-150: VALVE BOX ASSEMBLY

NOTE TO CONTRACTOR

DISSIMILAR PIPE CONNECTIONS

CONTRACTOR SHALL FIELD VERIFY DIMENSIONS OF EXISTING CAST IRON (CI), DUCTILE IRON (DI), ASBESTOS CEMENT (AC), OR OTHER PIPES, AT POINTS OF CONNECTION, CONSTRUCTION WORK. THE USE OF MODIFIED MECHANICAL JOINT BELLS, WITH OVERSIZE GLANDS, TO CONNECT EXISTING PIPES TO NEW MECHANICAL JOINT (MJ) PIPE AND FITTINGS IS ALLOWED, PER MANUFACTURER'S RECOMMENDATIONS. APPROVED TRANSITION COUPLINGS OR OTHER CAST ADAPTERS MAY ALSO BE USED BY THE CONTRACTOR AS AN OPTION TO CONNECT EXISTING DISSIMILAR PIPE TO NEW PIPE OR FITTINGS WHEN NECESSARY, WHETHER SHOWN OR NOT SHOWN ON THE PLANS.

SHEET INDEX

- 1 TITLE SHEET, VICINITY MAP, LOCATION MAP, STANDARD SYMBOLS, UTILITY INFORMATION
- 2 STANDARD NOTES FOR WATER CONSTRUCTION, SPECIAL NOTES TO CONTRACTOR, AND NPDES GENERAL NOTES
- 3 WATER PLAN - LOMITA BLVD TO WESTERN AVE
- 4 WATER PLAN - WESTERN AVE FROM LOMITA BLVD TO 248TH ST
- 5 WATER PLAN - 248TH STREET TO WESTERN AVENUE
- 6 WATER PLAN - 247TH PLACE TO WESTERN AVENUE
- 7 WATER PLAN - 247TH STREET TO WESTERN AVENUE
- 8 WATER PLAN - 246TH STREET TO WESTERN AVENUE
- 9 TYPICAL TRENCH SECTIONS
- 10 BUS PAD DETAILS
- 11 TRAFFIC CONTROL PLAN - GENERAL NOTES
- 12 TRAFFIC CONTROL PLAN - WESTERN AVENUE WORK AREA
- 13 TRAFFIC CONTROL PLAN - LOMITA BOULEVARD WORK AREA
- 14 TRAFFIC CONTROL PLAN - 248TH STREET WORK AREA
- 15 TRAFFIC CONTROL PLAN - 247TH PLACE WORK AREA
- 16 TRAFFIC CONTROL PLAN - 247TH STREET WORK AREA
- 17 TRAFFIC CONTROL PLAN - 246TH STREET WORK AREA
- 18 TRAFFIC CONTROL PLAN - WESTERN AVENUE FRONTAGE ROAD WORK AREAS 1 AND 3
- 19 TRAFFIC CONTROL PLAN - WESTERN AVENUE FRONTAGE ROAD WORK AREAS 2 AND 4
- 20 TRAFFIC CONTROL PLAN - WESTERN AVENUE AND 247TH STREET DETOUR PLAN
- 21 EROSION CONTROL PLAN



LOCATION MAP
NOT TO SCALE

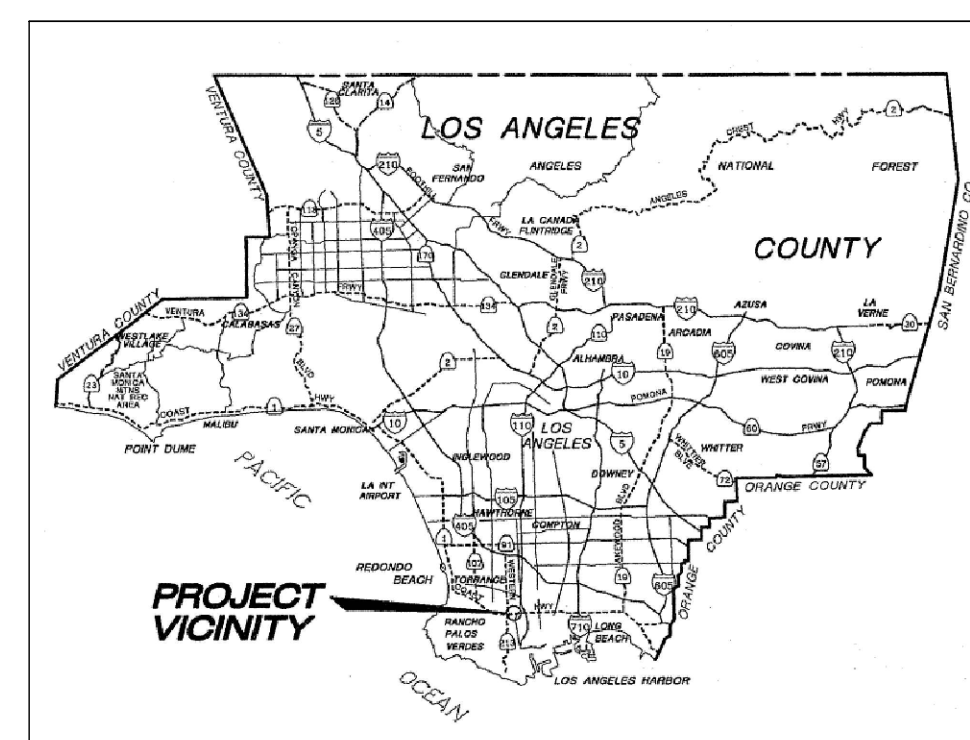

VICINITY MAP
NOT TO SCALE

NPDES GENERAL NOTES

1. CONTRACTOR MUST ENSURE THAT THE CONSTRUCTION SITE IS PREPARED PRIOR TO THE ONSET OF ANY STORM. CONTRACTOR SHALL HAVE ALL EROSION AND SEDIMENT CONTROL MEASURES IN PLACE.
2. ALL EROSION AND SEDIMENT CONTROL MEASURES SHALL BE MAINTAINED UNTIL DISTURBED AREAS ARE STABILIZED.
3. ALL EROSION AND SEDIMENT CONTROL MEASURES SHALL BE CHECKED BEFORE AND AFTER ALL STORMS TO ENSURE MEASURES ARE FUNCTIONING PROPERLY.
4. CONTRACTOR SHALL MAINTAIN A LOG AT THE SITE OF ALL INSPECTIONS OR MAINTENANCE OF BMPs AS WELL AS ANY CORRECTIVE CHANGES TO THE BMPs OR EROSION AND SEDIMENT CONTROL.
5. IN AREAS WHERE SOIL IS EXPOSED, PROMPT REPLANTING WITH NATIVE COMPATIBLE DROUGH-RESISTANT VEGETATION SHALL BE PERFORMED.
6. ALL SEDIMENT DEPOSITED ON PAVED ROADWAYS SHALL BE SWEEPED AT THE END OF EACH WORKING DAY OR AS NECESSARY.
7. CONTRACTOR SHALL PLACE BMPs AROUND ALL DRAINAGE STRUCTURE OPENINGS IMMEDIATELY AFTER THE STRUCTURE OPENING IS CONSTRUCTED. THESE SHALL BE MAINTAINED AND REMAIN IN PLACE UNTIL THE CONSTRUCTION IS COMPLETE.
8. CONTRACTOR SHALL IMPLEMENT HOUSEKEEPING PRACTICES AS FOLLOWS:
 - 8.A. SOLID WATER MANAGEMENT:
PROVIDE A DESIGNATED WASTE COLLECTION AREA AND CONTAINERS. ARRANGE FOR REGULAR REMOVAL AND DISPOSAL. CLEAR SITE OF TRASH INCLUDING ORGANIC DEBRIS, PACKAGING MATERIALS, SCRAP OR SURPLUS BUILDING MATERIALS AND DOMESTIC WASTE DAILY.
 - 8.B. CONCRETE WASTE:
PROVIDE A DESIGNATED AREA FOR A TEMPORARY PIT TO BE USED FOR CONCRETE TRUCK WASH-OUT. DISPOSE OF HARDENED CONCRETE OFFSITE. AT NO TIME SHALL A CONCRETE TRUCK DUMP ITS WASTE AND CLEAN ITS TRUCK INTO THE CITY STORM DRAIN VIA CURB AND GUTTER. INSPECT DAILY TO CONTROL RUNOFF AND WEEKLY FOR REMOVAL OF HARDENED CONCRETE.
 - 8.C. PAINT AND PRINTING SUPPLIES:
PROVIDE INSTRUCTION TO EMPLOYEES AND SUBCONTRACTORS REGARDING REDUCTION OF POLLUTANTS INCLUDING MATERIAL STORAGE, USE, AND CLEAN UP. INSPECT SITE WEEKLY FOR EVIDENCE OF IMPROPER DISPOSAL.
 - 8.D. VEHICLE FUELING, MAINTENANCE AND CLEANING:
PROVIDE A DESIGNATED FUELING AREA WITH SECONDARY CONTAINMENT SUCH AS BERMING. DO NOT ALLOW MOBILE FUELING OF EQUIPMENT. PROVIDE EQUIPMENT WITH DROP PANS. RESTRICT ONSITE MAINTENANCE AND CLEANING OF EQUIPMENT TO A MINIMUM.
 - 8.E. HAZARDOUS MATERIALS MANAGEMENT:
PREVENT THE DISCHARGE OF POLLUTANTS FROM HAZARDOUS MATERIALS TO THE DRAINAGE SYSTEM THROUGH PROPER MATERIAL USE, WASTE DISPOSAL AND TRAINING OF EMPLOYEES. HAZARDOUS WASTE PRODUCTS COMMONLY FOUND ON-SITE INCLUDE BUT ARE NOT LIMITED TO PAINTS & SOLVENTS, PETROLEUM PRODUCTS, FERTILIZERS, HERBICIDES & PESTICIDES, SOIL STABILIZATION PRODUCTS, ASPHALT PRODUCTS AND CONCRETE CURING PRODUCTS.

STANDARD SYMBOLS

⊙	WATER VALVE	— G —	GAS LINE
⊕	FIRE HYDRANT	— OIL —	OIL LINE
—	GUY WIRE	— SD —	STORM DRAIN LINE
⊙	LIGHT POLE	— S —	SEWER LINE
⊕	POWER POLE	— W —	WATER LINE
⊕	SEWER MANHOLE	— — — —	RIGHT OF WAY
⊕	SIGN		
⊕	STORM DRAIN MANHOLE		
⊕	TELECOMMUNICATIONS MANHOLE		
⊕	TRAFFIC SIGNAL		
⊕	UTILITY CABINET		
⊕	UTILITY VAULT		
⊕	WATER METER/SERVICE		

NO WORK SHALL BE DONE ON THIS SITE UNTIL BELOW AGENCY IS NOTIFIED OF INTENTION TO GRADE OR EXCAVATE.



Know what's below.
Call before you dig.

TWO WORKING DAYS BEFORE YOU DIG

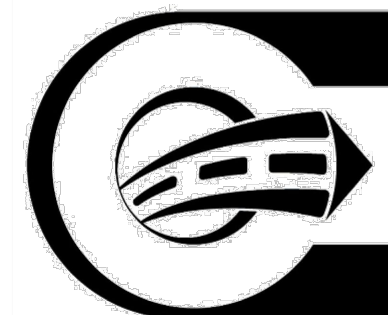

ONWARD ENGINEERING

300 S. HARBOR BLVD., SUITE 814
ANAHEIM, CA. 92805
P: (714) 533-3050
F: (714) 808-1270
ONWARDENGINEERING.COM

NO.	DATE	BY	DESCRIPTION	APPROVED
R E V I S I O N S				



PREPARED UNDER THE SUPERVISION OF:

Justin Smeets
JUSTIN SMEETS, PE
R.C.E. NO. 78314, EXP 09/30/23
DATE 8/31/2023

APPROVED BY :

SAM SAMPAT, P.E.
SENIOR CIVIL ENGINEER
DATE _____
ENGINEERING DIVISION

WATER MAIN REPLACEMENT
247TH STREET AREA

TITLE SHEET, UTILITY CONTACTS, VICINITY MAP, LOCATION MAP,
STANDARD SYMBOLS, NPDES/BMP GENERAL NOTES

DESIGNED BY :	R. DENNIS
DRAWN BY :	R. DENNIS
CHECKED BY :	J. SMEETS
PROJECT NO.	2021-1-WA
SHT	1 OF 21 SHTS

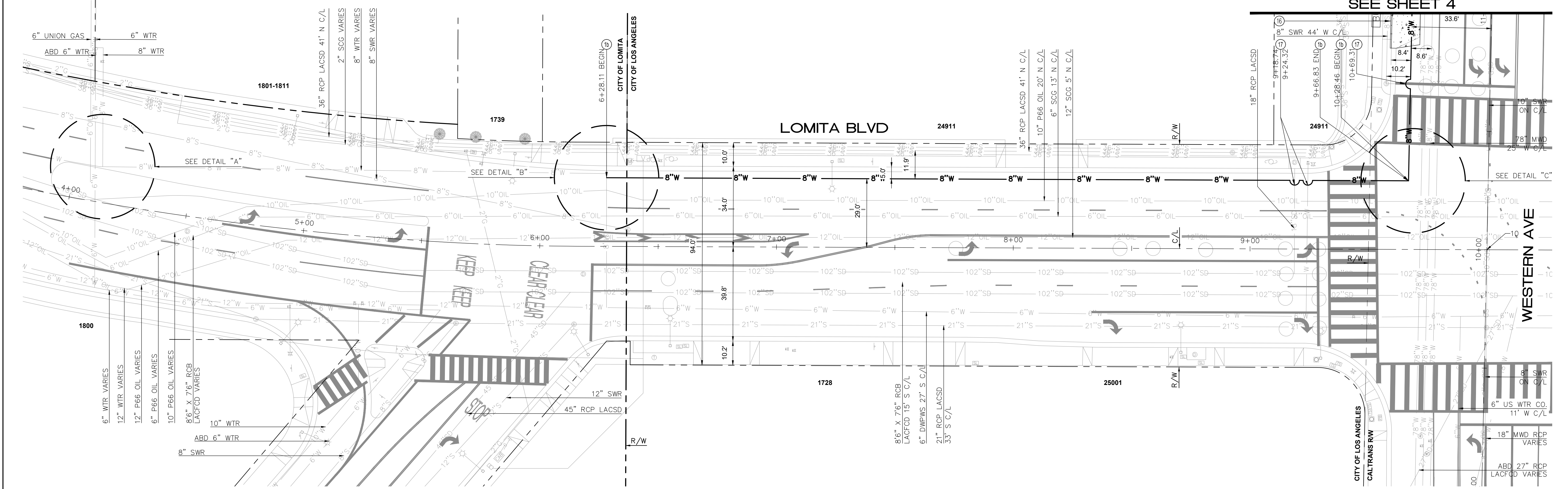

CONSTRUCTION NOTES

- 10) INSTALL NEW 8" POLYVINYL CHLORIDE (PVC) C900 DR14 WATER MAIN. CONSTRUCT TRENCH BACKFILL PER CITY OF LOMITA STD. PLAN NO. W-100.
- 6) INSTALL 8" X 8" X 8" TEE, (MJ X MJ X MJ).
- 7) INSTALL 8" RESILIENT GATE VALVE, (MJ X MJ).
- 9) INSTALL MECHANICAL JOINT RESTRAINER GLAND (MEGALUGS).
- 11) INSTALL DUCTILE IRON (DI) RESTRAINED LONG SOLID SLEEVE (MJ X MJ).
- 12) INSTALL DUCTILE IRON (DI) BLIND FLANGE.
- 13) CONSTRUCT THRUST BLOCK PER CITY OF LOMITA STD. PLAN NO. W-140.
- 14) EXISTING CAST IRON (CI) WATER MAIN TO BE ABANDONED IN PLACE. REMOVE INTERFERING PORTIONS, CUT AND PLUG WITH PCC (NO LESS THAN 6" THICK) AND ABANDON.
- 15) EXISTING DUCTILE IRON (DI) WATER MAIN. PROTECT IN PLACE.
- 16) RECONSTRUCT PCC BUS PAD PER DETAIL. SEE SHEET 10.
- 17) INSTALL 45 DEGREE BENDS AROUND EXISTING UTILITY PER DETAIL L ON SHEET 8.

GENERAL NOTES

CONTRACTOR TO USE PVC C900 DR 14 WHEN WATER MAIN IS WITHIN 10' OF SEWER MAIN.

CONTRACTOR TO COMPLY WITH THE CITY OF LOS ANGELES STANDARD PLAN S-477-2 FOR TRENCHING WHEN WORKING WITHIN THE CITY OF LOS ANGELES.

CONTRACTOR TO COMPLY WITH CALTRANS TYPICAL TRENCH DETAIL WHEN WORKING WITHIN THE CALTRANS RIGHT-OF-WAY.

UTILITY LOCATION INFORMATION WITHIN THE CITY OF LOS ANGELES IS AVAILABLE ON THE "NAVIGATE LA" SUBSTRUCTURE MAP.

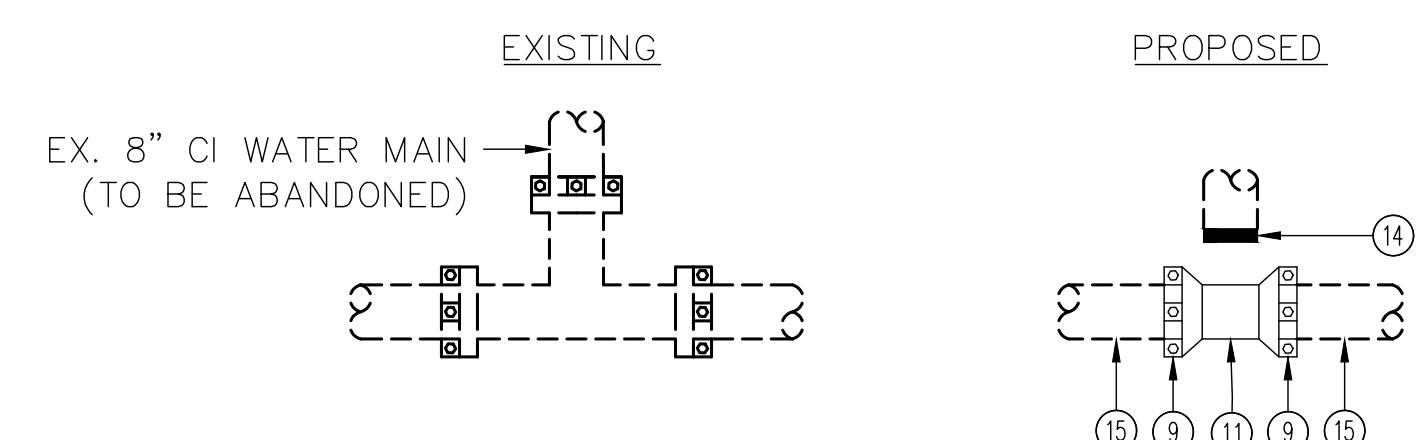

DETAIL "A" CONNECTION
NOT TO SCALE

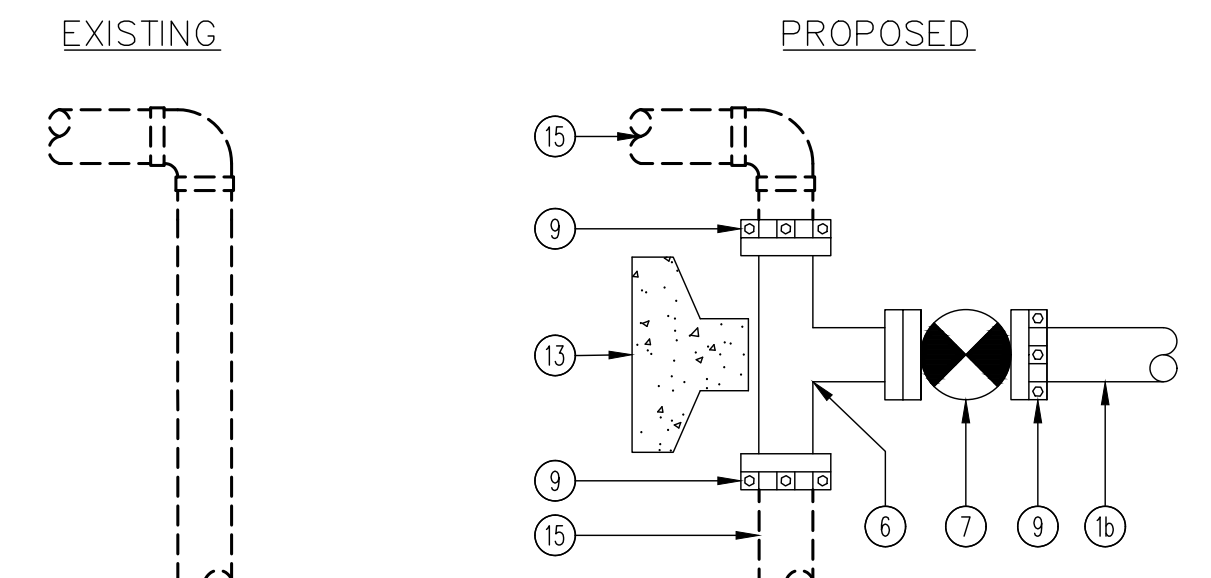

DETAIL "B" CONNECTION
NOT TO SCALE

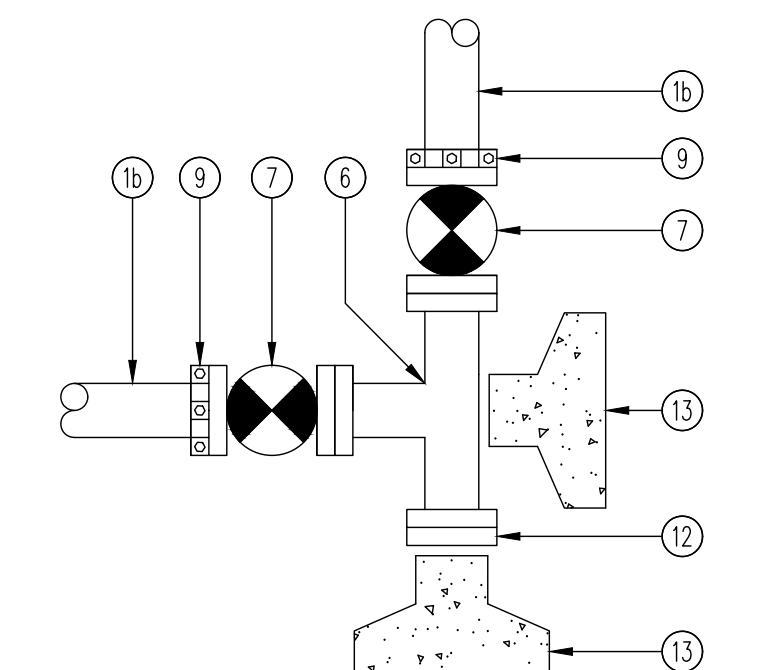

DETAIL "C" CONNECTION
NOT TO SCALE

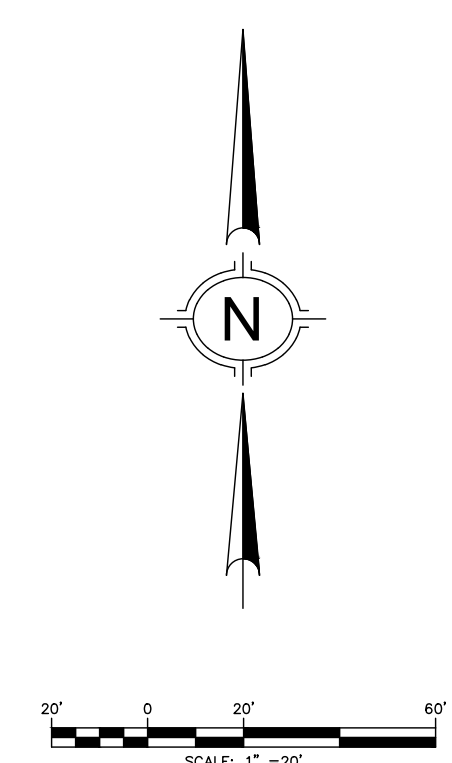

NO WORK SHALL BE DONE ON THIS SITE UNTIL BELOW AGENCY IS NOTIFIED OF INTENTION TO GRADE OR EXCAVATE.

Know what's below.
Call before you dig.

TWO WORKING DAYS BEFORE YOU DIG

ONWARD ENGINEERING
300 S. HARBOR BLVD., SUITE 814
ANAHEIM, CA. 92805
P: (714) 533-3050
F: (714) 808-1270
ONWARDENGINEERING.COM

NO.	DATE	BY	DESCRIPTION	APPROVED
REVISIONS				



PREPARED UNDER THE SUPERVISION OF:
Justin L. Smeets
JUSTIN SMEETS, PE
R.C.E. NO. 78314, EXP 09/30/23
8/31/2023
DATE

APPROVED BY:
SAM SAMPAT, P.E.
SENIOR CIVIL ENGINEER
DATE

ENGINEERING DIVISION

WATER MAIN REPLACEMENT
247TH STREET AREA
248TH STREET TO WESTERN AVENUE

PROJECT AND SHEET TITLE

DESIGNED BY: R. DENNIS
DRAWN BY: R. DENNIS
CHECKED BY: J. SMEETS
PROJECT NO. 2021-1-WA
SHT 3 OF 21 SHTS

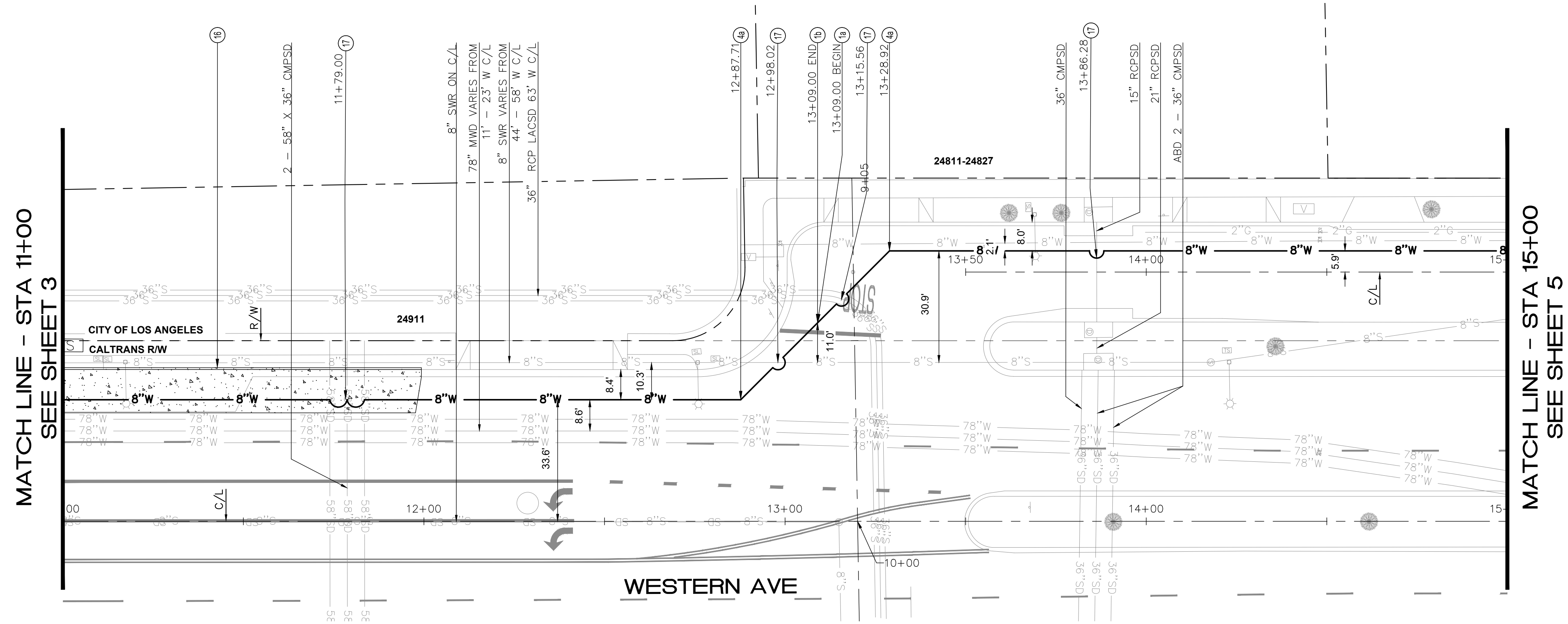

CONSTRUCTION NOTES

- (15) INSTALL NEW 8" POLYVINYL CHLORIDE (PVC) C900 DR18 WATER MAIN. CONSTRUCT TRENCH BACKFILL PER CITY OF LOMITA STD. PLAN NO. W-100.
- (16) INSTALL NEW 8" POLYVINYL CHLORIDE (PVC) C900 DR14 WATER MAIN. CONSTRUCT TRENCH BACKFILL PER CITY OF LOMITA STD. PLAN NO. W-100.
- (4) INSTALL 45 DEGREE BEND, (M J X M J). INSTALL RESTRAINING JOINTS A MINIMUM OF 13 FEET BEFORE AND AFTER BEND OR TO NEXT FITTING IF DISTANCE IS LESS.
- (16) RECONSTRUCT PCC BUS PAD PER DETAIL. SEE SHEET 10.
- (17) INSTALL 45 DEGREE BENDS AROUND EXISTING UTILITY PER DETAIL L ON SHEET 8.

GENERAL NOTES

CONTRACTOR TO USE PVC C900 DR 14 WHEN WATER MAIN IS WITHIN 10' OF SEWER MAIN.

CONTRACTOR TO COMPLY WITH THE CITY OF LOS ANGELES STANDARD PLAN S-477-2 FOR TRENCHING WHEN WORKING WITHIN THE CITY OF LOS ANGELES.

CONTRACTOR TO COMPLY WITH CALTRANS TYPICAL TRENCH DETAIL WHEN WORKING WITHIN THE CALTRANS RIGHT-OF-WAY.

UTILITY LOCATION INFORMATION WITHIN THE CITY OF LOS ANGELES IS AVAILABLE ON THE "NAVIGATE LA" SUBSTRUCTURE MAP.

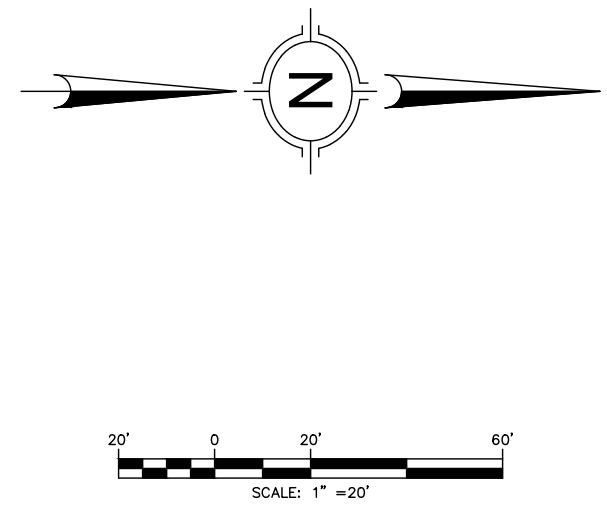

NO WORK SHALL BE DONE ON THIS SITE UNTIL BELOW AGENCY IS NOTIFIED OF INTENTION TO GRADE OR EXCAVATE.

811
Know what's below.
Call before you dig.
TWO WORKING DAYS BEFORE YOU DIG

ONWARD ENGINEERING
300 S. HARBOR BLVD., SUITE 814
ANAHEIM, CA. 92805
P: (714) 533-3050
F: (714) 808-1270
ONWARDENGINEERING.COM

NO.	DATE	BY	DESCRIPTION	APPROVED
R E V I S I O N S				



PREPARED UNDER THE SUPERVISION OF:
Justin Smeets
JUSTIN SMEETS, PE
R.C.E. NO. 78314, EXP 09/30/23
DATE: 8/31/2023

APPROVED BY:
SAM SAMPAT, P.E.
SENIOR CIVIL ENGINEER
DATE: _____
ENGINEERING DIVISION

WATER MAIN REPLACEMENT
247TH STREET AREA
WESTERN AVENUE FROM LOMITA BOULEVARD TO 248TH STREET

DESIGNED BY: R. DENNIS
DRAWN BY: R. DENNIS
CHECKED BY: J. SMEETS
PROJECT NO. 2021-1-WA
SHT 4 OF 21 SHTS

Sep 05, 2023 - 2:43pm - C:\Users\JustinSmeets\Box\Projects\Design\247th Street Area Water Main Replacement\Project\Design\CAD\Plan\4 Western Ave.dwg

MATCH LINE - STA 17+00
SEE SHEET 6

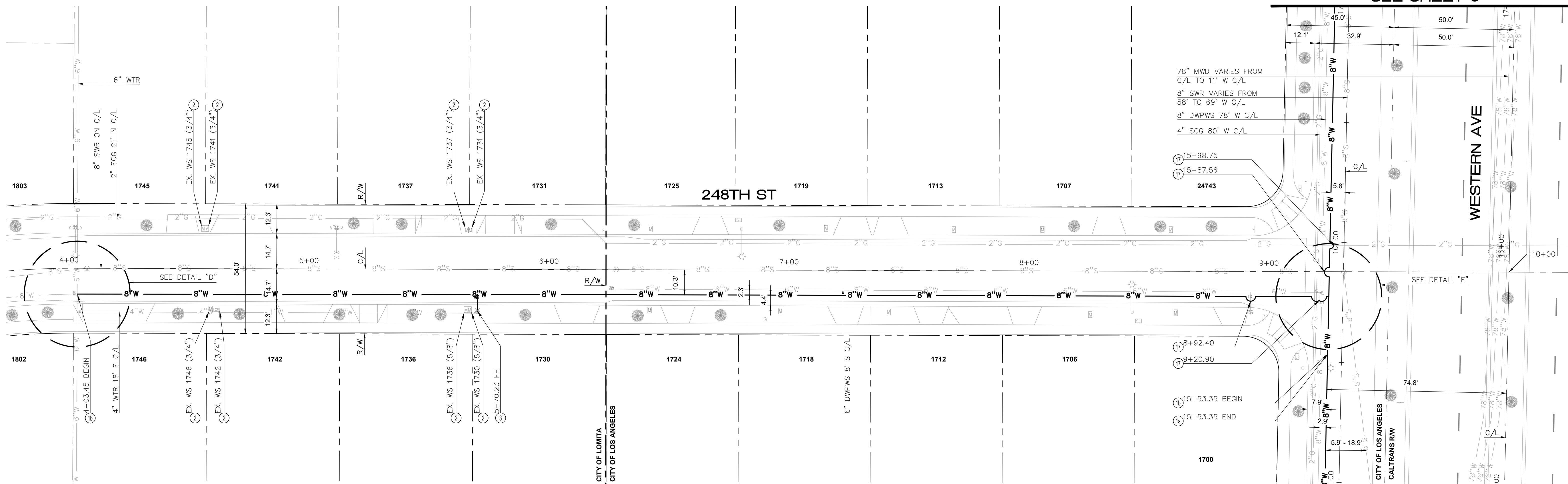

78" MWD VARIES FROM
C/L TO 11' W C/L
8" SWR VARIES FROM
58' TO 69' W C/L
8" DWPWS 78' W C/L
4" SCG 80' W C/L

17 15+98.75
17 15+87.56
24743

17 8+92.40
17 9+20.90
1b 15+53.35 BEGIN
1a 15+53.35 END

MATCH LINE - STA 15+00
SEE SHEET 4

CONSTRUCTION NOTES

- 1) INSTALL NEW 8" POLYVINYL CHLORIDE (PVC) C900 DR18 WATER MAIN. CONSTRUCT TRENCH BACKFILL PER CITY OF LOMITA STD. PLAN NO. W-100.
- 2) INSTALL NEW 8" POLYVINYL CHLORIDE (PVC) C900 DR14 WATER MAIN. CONSTRUCT TRENCH BACKFILL PER CITY OF LOMITA STD. PLAN NO. W-100.
- 3) CONSTRUCT NEW 1" SERVICE LINE PER CITY OF LOMITA STD. PLAN NO. W-101. ABANDON EXISTING SERVICE LINE IN PLACE. CONTRACTOR TO CONNECT TO EXISTING METER AND PROTECT EXISTING METER BOX.
- 4) INSTALL NEW 6" FIRE HYDRANT ASSEMBLY PER CITY OF LOMITA STD. PLAN NO. W-110 (INCLUSIVE OF GATE VALVE).
- 5) INSTALL 8" X 8" X 8" TEE, (MJ X MJ X MJ).
- 6) INSTALL 8" RESILIENT GATE VALVE, (MJ X MJ).
- 7) INSTALL MECHANICAL JOINT RESTRAINER GLAND (MEGALUGS).
- 8) INSTALL DUCTILE IRON (DI) RESTRAINED LONG SOLID SLEEVE (MJ X MJ).
- 9) CONSTRUCT THRUST BLOCK PER CITY OF LOMITA STD. PLAN NO. W-140.
- 10) EXISTING CAST IRON (CI) WATER MAIN TO BE ABANDONED IN PLACE. REMOVE INTERFERING PORTIONS, CUT AND PLUG WITH PCC (NO LESS THAN 6" THICK) AND ABANDON.
- 11) EXISTING DUCTILE IRON (DI) WATER MAIN. PROTECT IN PLACE.
- 12) INSTALL 45 DEGREE BENDS AROUND EXISTING UTILITY PER DETAIL L ON SHEET 8.

WATER SERVICE REPLACEMENT SCHEDULE

ADDRESS	METER NUMBER	SERIAL NUMBER	EXISTING		PROPOSED	
			SERVICE SIZE	METER SIZE	SERVICE SIZE	METER SIZE
1730 248TH ST	67217044	1852301549	5/8"	5/8"	1"	REUSE EX.
1731 248TH ST	52571732	1543651186	3/4"	3/4"	1"	REUSE EX.
1736 248TH ST	67217005	1852326299	5/8"	5/8"	1"	REUSE EX.
1737 248TH ST	52571734	1834071129	3/4"	3/4"	1"	REUSE EX.
1741 248TH ST	53156805	1852395131	3/4"	3/4"	1"	REUSE EX.
1742 248TH ST	53156785	1852388742	3/4"	3/4"	1"	REUSE EX.
1745 248TH ST	53156806	1852389518	3/4"	3/4"	1"	REUSE EX.
1746 248TH ST	53156780	1852388687	3/4"	3/4"	1"	REUSE EX.

GENERAL NOTES

CONTRACTOR TO USE PVC C900 DR 14 WHEN WATER MAIN IS WITHIN 10' OF SEWER MAIN.

CONTRACTOR TO COMPLY WITH THE CITY OF LOS ANGELES STANDARD PLAN S-477-2 FOR TRENCHING WHEN WORKING WITHIN THE CITY OF LOS ANGELES.

CONTRACTOR TO COMPLY WITH CALTRANS TYPICAL TRENCH DETAIL WHEN WORKING WITHIN THE CALTRANS RIGHT-OF-WAY.

UTILITY LOCATION INFORMATION WITHIN THE CITY OF LOS ANGELES IS AVAILABLE ON THE "NAVIGATE LA" SUBSTRUCTURE MAP.

EXISTING

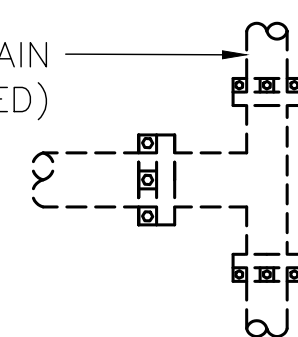

EX. 6" CI WATER MAIN
(TO BE ABANDONED)

PROPOSED

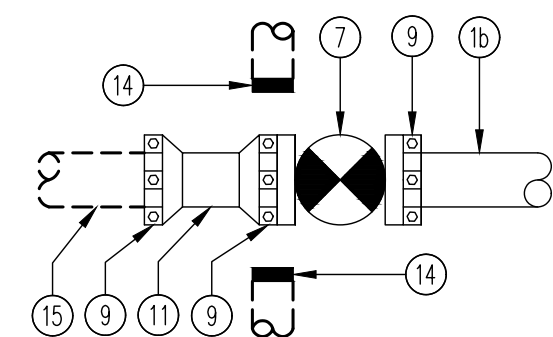

DETAIL "D" CONNECTION
NOT TO SCALE

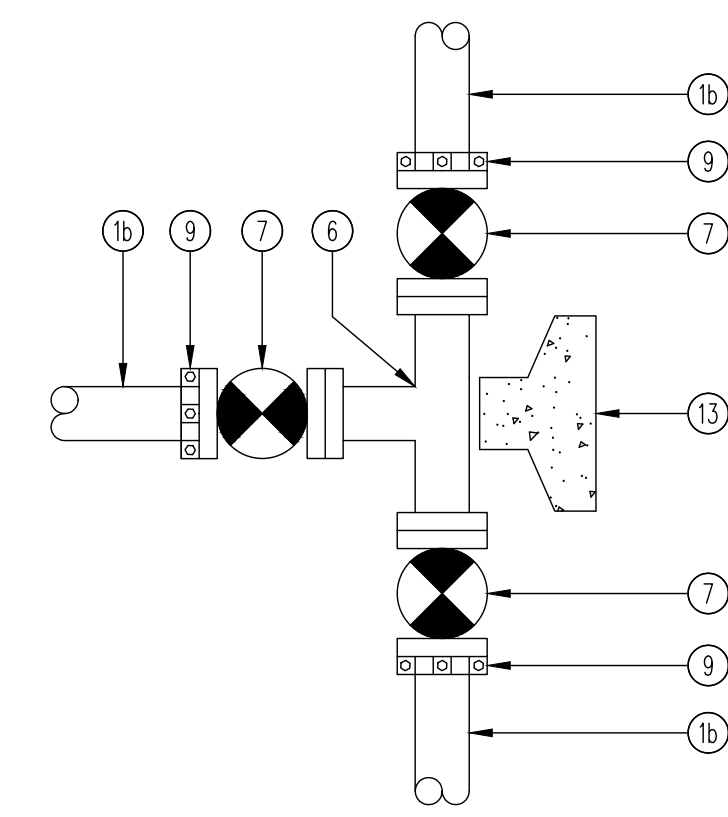

DETAIL "E" CONNECTION
NOT TO SCALE

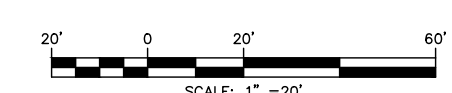
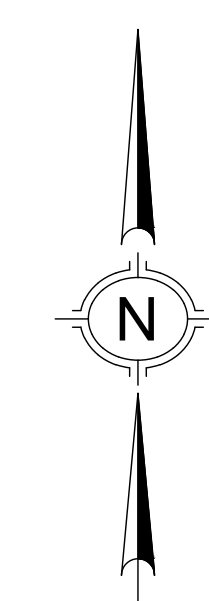

NO WORK SHALL BE DONE ON THIS SITE UNTIL BELOW AGENCY IS NOTIFIED OF INTENTION TO GRADE OR EXCAVATE.

Know what's below.
Call before you dig.

TWO WORKING DAYS BEFORE YOU DIG

ONWARD ENGINEERING

300 S. HARBOR BLVD., SUITE 814
ANAHEIM, CA. 92805
P: (714) 533-3050
F: (714) 808-1270
ONWARDENGINEERING.COM

NO.	DATE	BY	DESCRIPTION	APPROVED
R E V I S I O N S				



PREPARED UNDER THE SUPERVISION OF:

Justin Smeets
JUSTIN SMEETS, PE
R.C.E. NO. 78314, EXP 09/30/23

8/31/2023
DATE

APPROVED BY:

SAM SAMPAT, P.E.
SENIOR CIVIL ENGINEER

DATE

ENGINEERING DIVISION

WATER MAIN REPLACEMENT

247TH STREET AREA

248TH STREET TO WESTERN AVENUE

PROJECT AND SHEET TITLE

DESIGNED BY:
R. DENNIS

DRAWN BY:
R. DENNIS

CHECKED BY:
J. SMEETS

PROJECT NO.
2021-1-WA

SHT 5 OF 21 SHTS

Sep 05, 2023 - 2:44pm - C:\Users\JustinSmeets\Box\Projects\Design\247th Street Area Water Main Replacement\Project\CAD\Drawings\248 St.dwg

MATCH LINE - STA 20+00
SEE SHEET 7

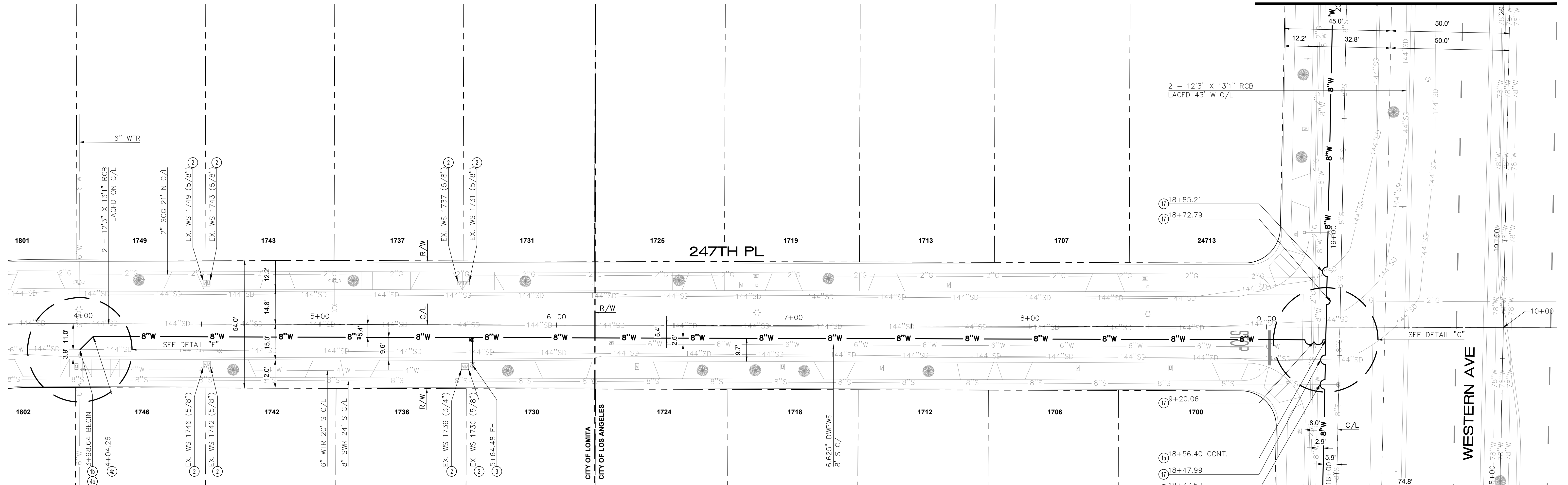

CONSTRUCTION NOTES

- 1) INSTALL NEW 8" POLYVINYL CHLORIDE (PVC) C900 DR14 WATER MAIN. CONSTRUCT TRENCH BACKFILL PER CITY OF LOMITA STD. PLAN NO. W-100.
- 2) CONSTRUCT NEW 1" SERVICE LINE PER CITY OF LOMITA STD. PLAN NO. W-101. ABANDON EXISTING SERVICE LINE IN PLACE. CONTRACTOR TO CONNECT TO EXISTING METER AND PROTECT EXISTING METER BOX.
- 3) INSTALL NEW 6" FIRE HYDRANT ASSEMBLY PER CITY OF LOMITA STD. PLAN NO. W-110 (INCLUSIVE OF GATE VALVE).
- 4) INSTALL 45 DEGREE BEND, (MJ X MJ). INSTALL RESTRAINING JOINTS A MINIMUM OF 13 FEET BEFORE AND AFTER BEND OR TO NEXT FITTING IF DISTANCE IS LESS.
- 5) INSTALL 8" X 8" X 8" TEE, (MJ X MJ X MJ).
- 6) INSTALL 8" RESILIENT GATE VALVE, (MJ X MJ).
- 7) INSTALL 8" TO 6" REDUCER, (MJ X MJ). INSTALL RESTRAINING JOINTS A MINIMUM OF 31 FEET BEYOND THE 8 INCH END OF THE REDUCER OR TO THE NEXT FITTING IF THE DISTANCE IS LESS.
- 8) INSTALL MECHANICAL JOINT RESTRAINER GLAND (MEGALUGS).
- 9) INSTALL DUCTILE IRON (DI) SPOOL (LENGTH TO BE DETERMINED IN FIELD).
- 10) INSTALL DUCTILE IRON (DI) RESTRAINED LONG SOLID SLEEVE (MJ X MJ).
- 11) CONSTRUCT THRUST BLOCK PER CITY OF LOMITA STD. PLAN NO. W-140.
- 12) EXISTING CAST IRON (CI) WATER MAIN TO BE ABANDONED IN PLACE. REMOVE INTERFERING PORTIONS, CUT AND PLUG WITH PCC (NO LESS THAN 6" THICK) AND ABANDON.
- 13) EXISTING DUCTILE IRON (DI) WATER MAIN. PROTECT IN PLACE.
- 14) INSTALL 45 DEGREE BENDS AROUND EXISTING UTILITY PER DETAIL L ON SHEET 8.

WATER SERVICE REPLACEMENT SCHEDULE

ADDRESS	METER NUMBER	SERIAL NUMBER	EXISTING		PROPOSED	
			SERVICE SIZE	METER SIZE	SERVICE SIZE	METER SIZE
1730 247TH PL	67217140	1852330004	5/8"	5/8"	1"	REUSE EX.
1731 247TH PL	67217054	1852319601	5/8"	5/8"	1"	REUSE EX.
1736 247TH PL	53156781	1852389364	3/4"	3/4"	1"	REUSE EX.
1737 247TH PL	67217147	1852380369	5/8"	5/8"	1"	REUSE EX.
1742 247TH PL	67217076	1852321958	5/8"	5/8"	1"	REUSE EX.
1743 247TH PL	67217104	1852302033	5/8"	5/8"	1"	REUSE EX.
1746 247TH PL	67217137	1852330016	5/8"	5/8"	1"	REUSE EX.
1749 247TH PL	67217118	1852304335	5/8"	5/8"	1"	REUSE EX.

GENERAL NOTES

CONTRACTOR TO USE PVC C900 DR 14 WHEN WATER MAIN IS WITHIN 10' OF SEWER MAIN.

CONTRACTOR TO COMPLY WITH THE CITY OF LOS ANGELES STANDARD PLAN S-477-2 FOR TRENCHING WHEN WORKING WITHIN THE CITY OF LOS ANGELES.

CONTRACTOR TO COMPLY WITH CALTRANS TYPICAL TRENCH DETAIL WHEN WORKING WITHIN THE CALTRANS RIGHT-OF-WAY.

UTILITY LOCATION INFORMATION WITHIN THE CITY OF LOS ANGELES IS AVAILABLE ON THE "NAVIGATE LA" SUBSTRUCTURE MAP.

PROPOSED

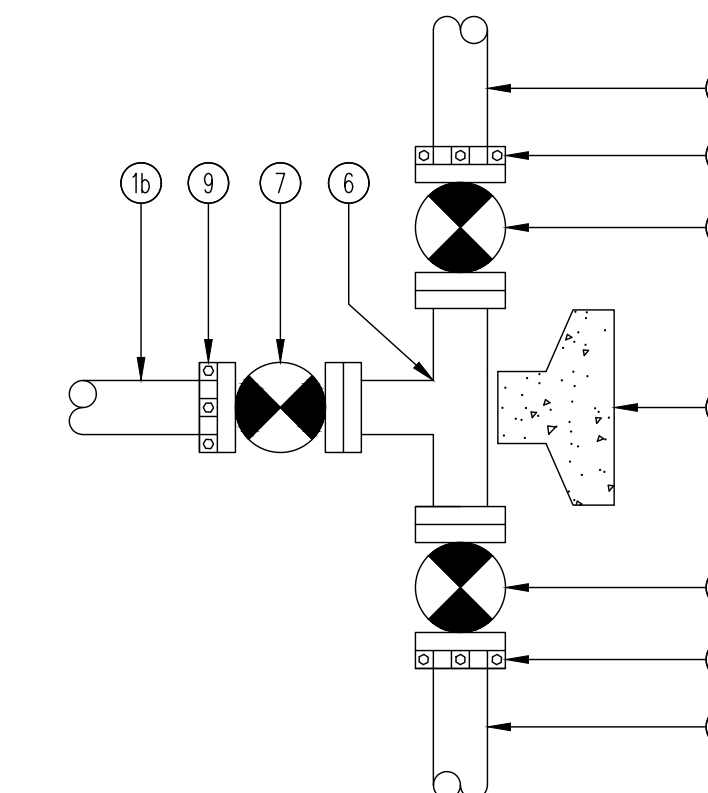
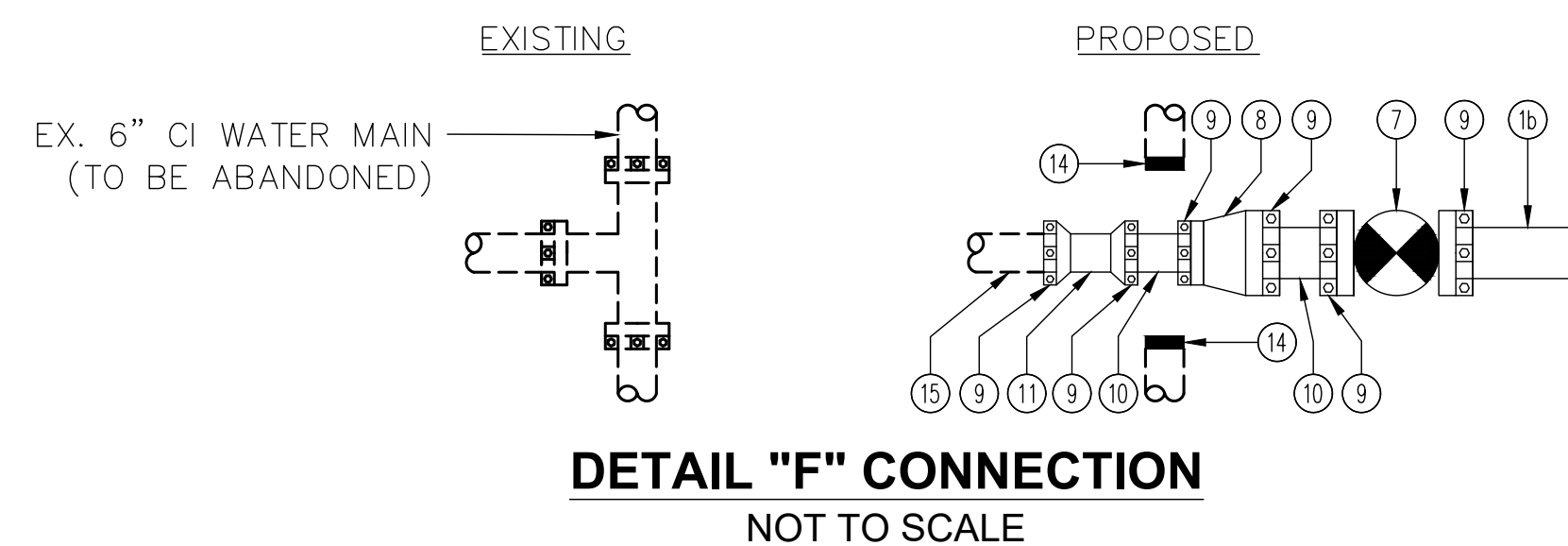

MATCH LINE - STA 17+00
SEE SHEET 5

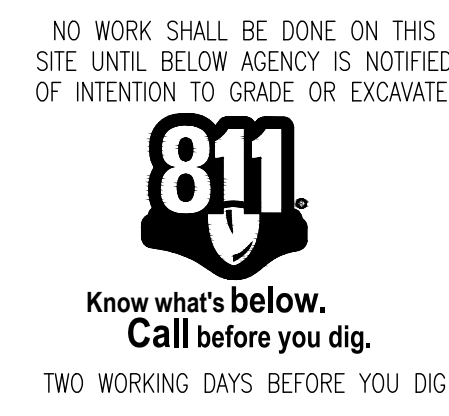
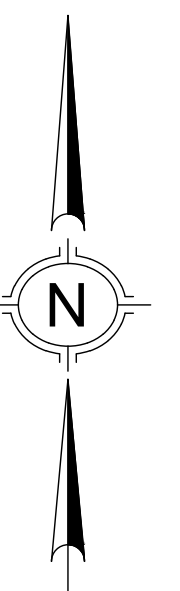

ONWARD ENGINEERING
300 S. HARBOR BLVD., SUITE 814
ANAHEIM, CA. 92805
P: (714) 533-3050
F: (714) 808-1270
ONWARDENGINEERING.COM

NO.	DATE	BY	DESCRIPTION	APPROVED
REVISIONS				



PREPARED UNDER THE SUPERVISION OF:
Justin L. Smeets
JUSTIN SMEETS, PE
R.C.E. NO. 78314, EXP 09/30/23
DATE 8/31/2023

APPROVED BY:
SAM SAMPAT, P.E.
SENIOR CIVIL ENGINEER
DATE _____
ENGINEERING DIVISION

WATER MAIN REPLACEMENT
247TH STREET AREA
247TH PLACE TO WESTERN AVENUE

DESIGNED BY: R. DENNIS
DRAWN BY: R. DENNIS
CHECKED BY: J. SMEETS
PROJECT NO. 2021-1-WA
SHT 6 OF 21 SHTS

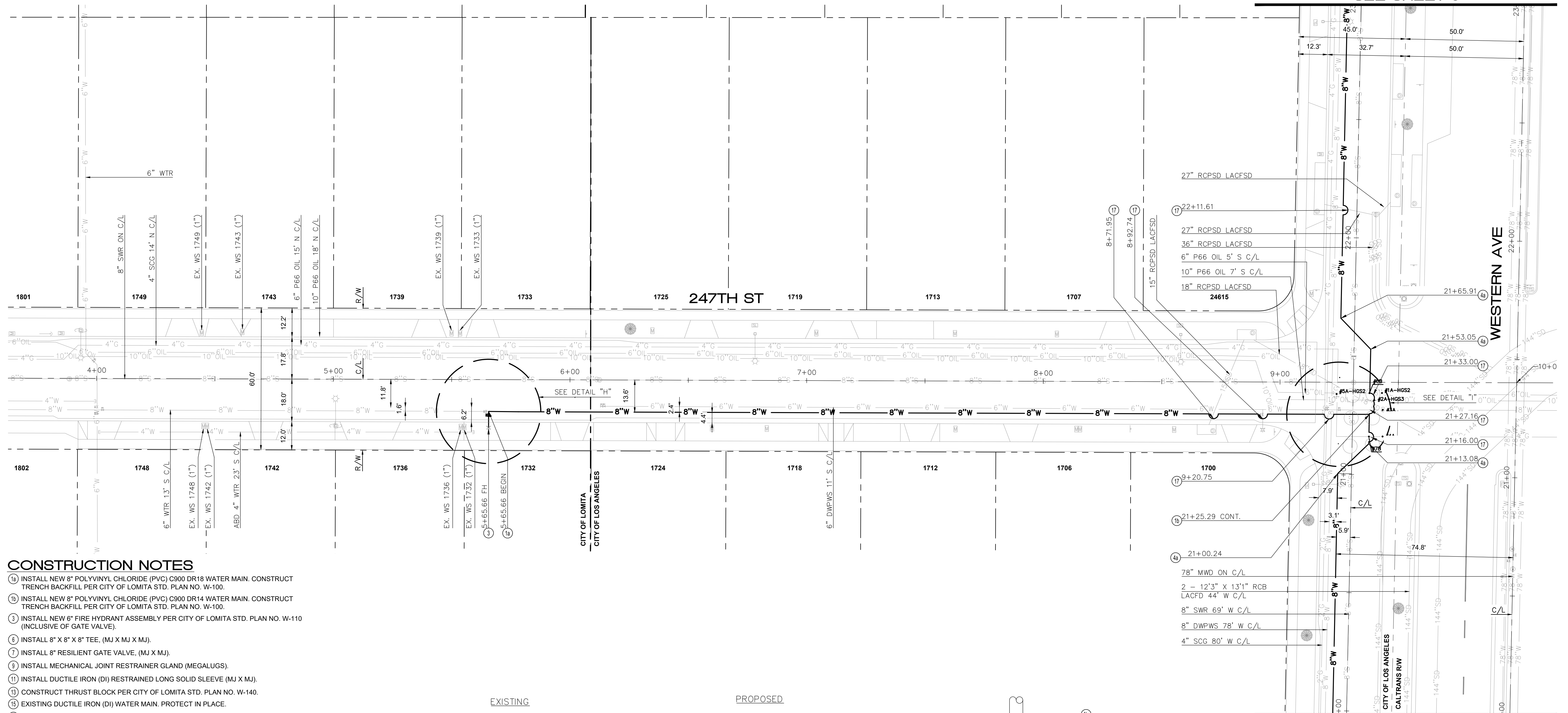

CONSTRUCTION NOTES

- 1) INSTALL NEW 8" POLYVINYL CHLORIDE (PVC) C900 DR18 WATER MAIN. CONSTRUCT TRENCH BACKFILL PER CITY OF LOMITA STD. PLAN NO. W-100.
- 2) INSTALL NEW 8" POLYVINYL CHLORIDE (PVC) C900 DR14 WATER MAIN. CONSTRUCT TRENCH BACKFILL PER CITY OF LOMITA STD. PLAN NO. W-100.
- 3) INSTALL NEW 6" FIRE HYDRANT ASSEMBLY PER CITY OF LOMITA STD. PLAN NO. W-110 (INCLUSIVE OF GATE VALVE).
- 6) INSTALL 8" X 8" X 8" TEE, (MJ X MJ X MJ).
- 7) INSTALL 8" RESILIENT GATE VALVE, (MJ X MJ).
- 9) INSTALL MECHANICAL JOINT RESTRAINER GLAND (MEGALUGS).
- 11) INSTALL DUCTILE IRON (DI) RESTRAINED LONG SOLID SLEEVE (MJ X MJ).
- 12) CONSTRUCT THRUST BLOCK PER CITY OF LOMITA STD. PLAN NO. W-140.
- 13) EXISTING DUCTILE IRON (DI) WATER MAIN. PROTECT IN PLACE.
- 17) INSTALL 45 DEGREE BENDS AROUND EXISTING UTILITY PER DETAIL L ON SHEET 8.

GENERAL NOTES

CONTRACTOR TO USE PVC C900 DR 14 WHEN WATER MAIN IS WITHIN 10' OF SEWER MAIN.

CONTRACTOR TO COMPLY WITH THE CITY OF LOS ANGELES STANDARD PLAN S-477-2 FOR TRENCHING WHEN WORKING WITHIN THE CITY OF LOS ANGELES.

CONTRACTOR TO COMPLY WITH CALTRANS TYPICAL TRENCH DETAIL WHEN WORKING WITHIN THE CALTRANS RIGHT-OF-WAY.

UTILITY LOCATION INFORMATION WITHIN THE CITY OF LOS ANGELES IS AVAILABLE ON THE "NAVIGATE LA" SUBSTRUCTURE MAP.

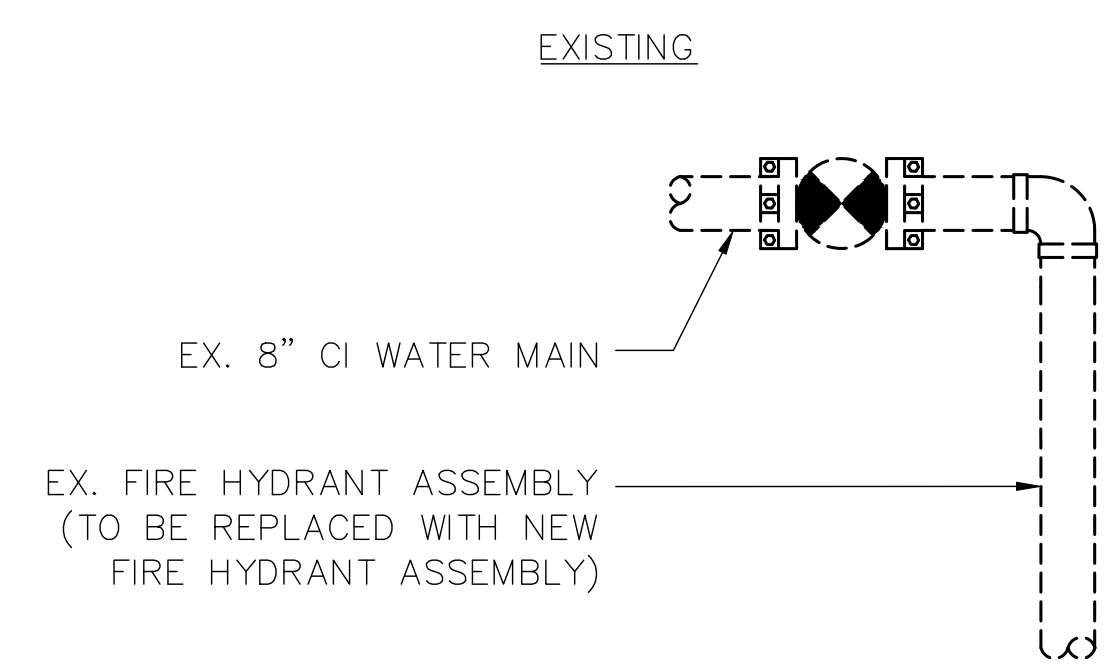

DETAIL "H" CONNECTION
NOT TO SCALE

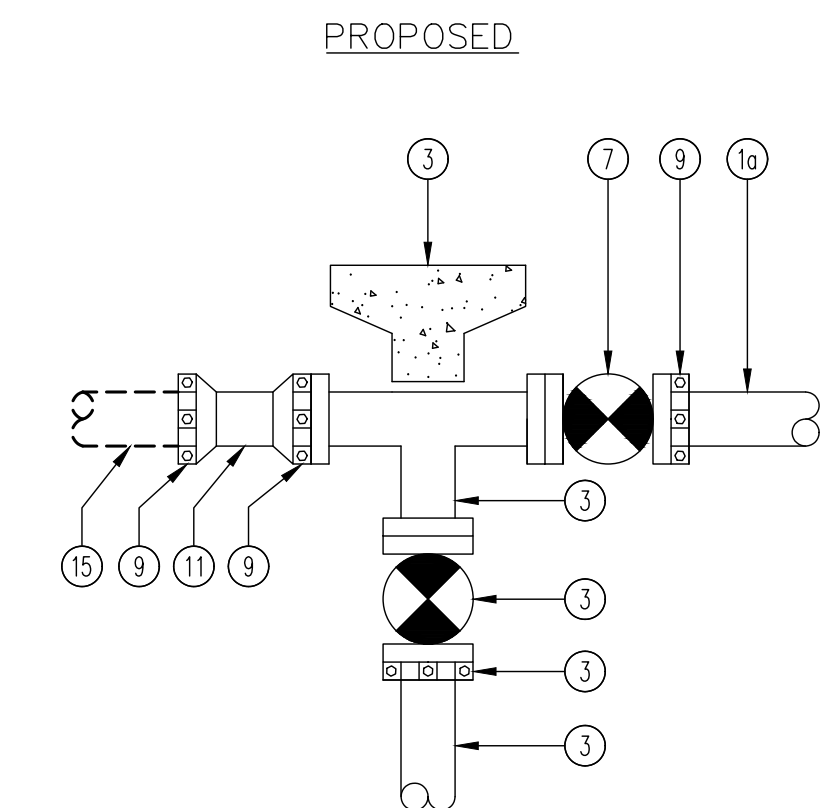

DETAIL "I" CONNECTION
NOT TO SCALE

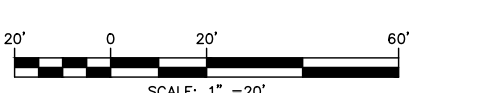
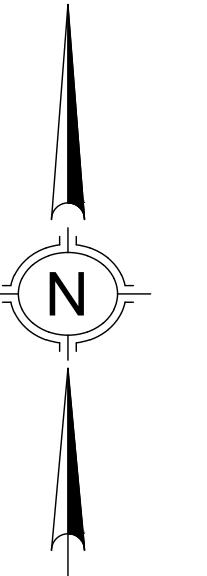
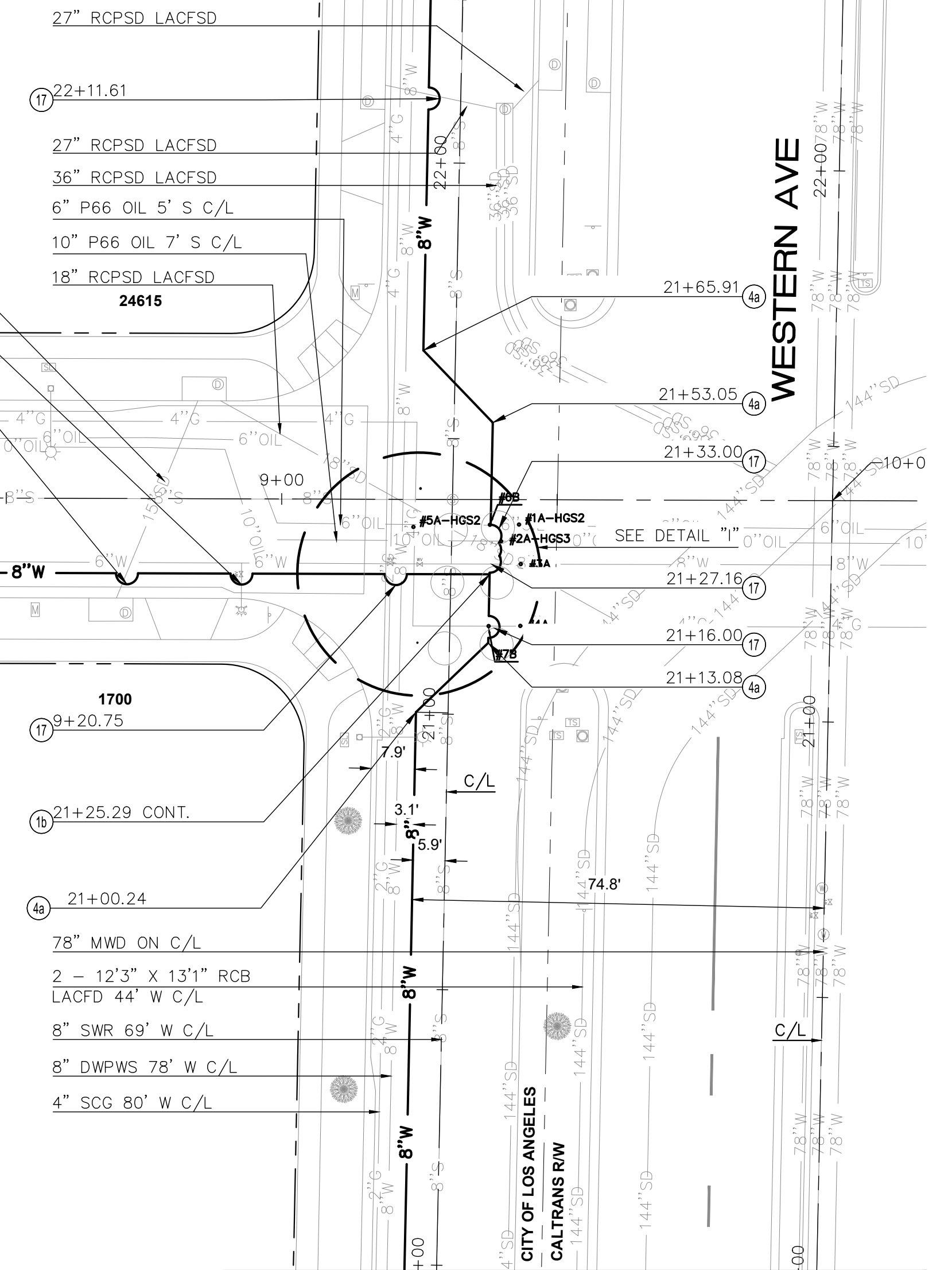

NO WORK SHALL BE DONE ON THIS SITE UNTIL BELOW AGENCY IS NOTIFIED OF INTENTION TO GRADE OR EXCAVATE.

Know what's below.
Call before you dig.

TWO WORKING DAYS BEFORE YOU DIG

ONWARD ENGINEERING
300 S. HARBOR BLVD., SUITE 814
ANAHEIM, CA. 92805
P: (714) 533-3050
F: (714) 808-1270
ONWARDENGINEERING.COM

NO.	DATE	BY	DESCRIPTION	APPROVED
R E V I S I O N S				



PREPARED UNDER THE SUPERVISION OF:

Justin Smeets
JUSTIN SMEETS, PE
R.C.E. NO. 78314, EXP 09/30/23

DATE: 8/31/2023

APPROVED BY:

SAM SAMPAT, P.E.
SENIOR CIVIL ENGINEER

DATE: _____

ENGINEERING DIVISION

WATER MAIN REPLACEMENT

247TH STREET AREA

247TH STREET TO WESTERN AVENUE

PROJECT AND SHEET TITLE

DESIGNED BY : R. DENNIS
DRAWN BY : R. DENNIS
CHECKED BY : J. SMEETS

PROJECT NO. 2021-1-WA

SHT 7 OF 21 SHTS

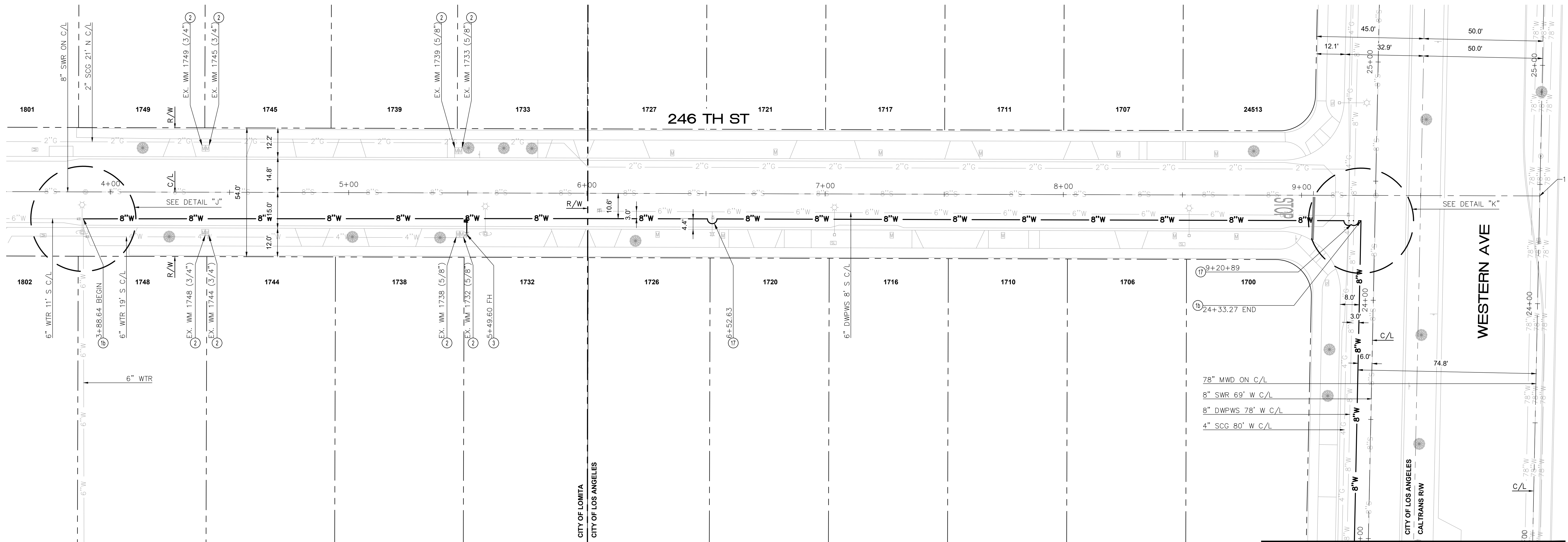

MATCH LINE - STA 23+00
SEE SHEET 7

CONSTRUCTION NOTES

- 1b) INSTALL NEW 8" POLYVINYL CHLORIDE (PVC) C900 DR14 WATER MAIN. CONSTRUCT TRENCH BACKFILL PER CITY OF LOMITA STD. PLAN NO. W-100.
- 2) CONSTRUCT NEW 1" SERVICE LINE PER CITY OF LOMITA STD. PLAN NO. W-101. ABANDON EXISTING SERVICE LINE IN PLACE. CONTRACTOR TO CONNECT TO EXISTING METER AND PROTECT EXISTING METER BOX.
- 3) INSTALL NEW 6" FIRE HYDRANT ASSEMBLY PER CITY OF LOMITA STD. PLAN NO. W-110 (INCLUSIVE OF GATE VALVE).
- 4a) INSTALL 45 DEGREE BEND, (MJ X MJ). INSTALL RESTRAINING JOINTS A MINIMUM OF 47 FEET BEFORE AND AFTER BEND OR TO NEXT FITTING IF DISTANCE IS LESS.
- 4b) INSTALL 45 DEGREE BEND, (MJ X MJ). INSTALL RESTRAINING JOINTS A MINIMUM OF 10 FEET BEFORE AND AFTER BEND OR TO NEXT FITTING IF DISTANCE IS LESS.
- 5) INSTALL 8" X 8" X 8" TEE, (MJ X MJ X MJ).
- 6) INSTALL 8" RESILIENT GATE VALVE, (MJ X MJ).
- 7) INSTALL 8" TO 6" REDUCER, (MJ X MJ). INSTALL RESTRAINING JOINTS A MINIMUM OF 31 FEET BEYOND THE 8 INCH END OF THE REDUCER OR TO THE NEXT FITTING IF THE DISTANCE IS LESS.
- 8) INSTALL MECHANICAL JOINT RESTRAINER GLAND (MEGALUGS).
- 9) INSTALL DUCTILE IRON (DI) SPOOL (LENGTH TO BE DETERMINED IN FIELD).
- 10) INSTALL DUCTILE IRON (DI) RESTRAINED LONG SOLID SLEEVE (MJ X MJ).
- 11) INSTALL DUCTILE IRON (DI) BLIND FLANGE.
- 12) CONSTRUCT THRUST BLOCK PER CITY OF LOMITA STD. PLAN NO. W-140.
- 13) EXISTING CAST IRON (CI) WATER MAIN TO BE ABANDONED IN PLACE. REMOVE INTERFERING PORTIONS, CUT AND PLUG WITH PCC (NO LESS THAN 6" THICK) AND ABANDON.
- 14) EXISTING DUCTILE IRON (DI) WATER MAIN. PROTECT IN PLACE.
- 15) INSTALL 45 DEGREE BENDS AROUND EXISTING UTILITY PER DETAIL L ON SHEET 8.

GENERAL NOTES

CONTRACTOR TO USE PVC C900 DR 14 WHEN WATER MAIN IS WITHIN 10' OF SEWER MAIN.

CONTRACTOR TO COMPLY WITH THE CITY OF LOS ANGELES STANDARD PLAN S-477-2 FOR TRENCHING WHEN WORKING WITHIN THE CITY OF LOS ANGELES.

CONTRACTOR TO COMPLY WITH CALTRANS TYPICAL TRENCH DETAIL WHEN WORKING WITHIN THE CALTRANS RIGHT-OF-WAY.

UTILITY LOCATION INFORMATION WITHIN THE CITY OF LOS ANGELES IS AVAILABLE ON THE "NAVIGATE LA" SUBSTRUCTURE MAP.

WATER SERVICE REPLACEMENT SCHEDULE

ADDRESS	METER NUMBER	SERIAL NUMBER	EXISTING		PROPOSED	
			SERVICE SIZE	METER SIZE	SERVICE SIZE	METER SIZE
1732 246TH ST	35263166	1852296828	5/8"	5/8"	1"	REUSE EX.
1733 246TH ST	67217064	1852395576	5/8"	5/8"	1"	REUSE EX.
1738 246TH ST	67217066	1852325010	5/8"	5/8"	1"	REUSE EX.
1739 246TH ST	67217043	1852280132	5/8"	5/8"	1"	REUSE EX.
1744 246TH ST	52954484	1850492700	3/4"	3/4"	1"	REUSE EX.
1745 246TH ST	52269375	1852383417	3/4"	3/4"	1"	REUSE EX.
1748 246TH ST	53156815	1852385962	3/4"	3/4"	1"	REUSE EX.
1749 246TH ST	52907087	1850408063	3/4"	3/4"	1"	REUSE EX.

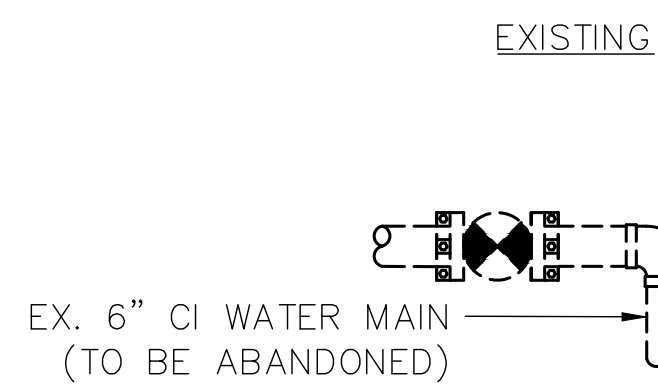

DETAIL "J" CONNECTION
NOT TO SCALE

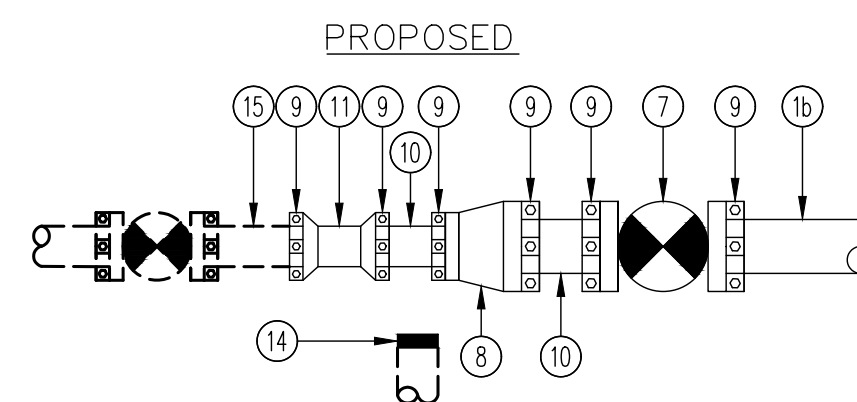

DETAIL "K" CONNECTION
NOT TO SCALE

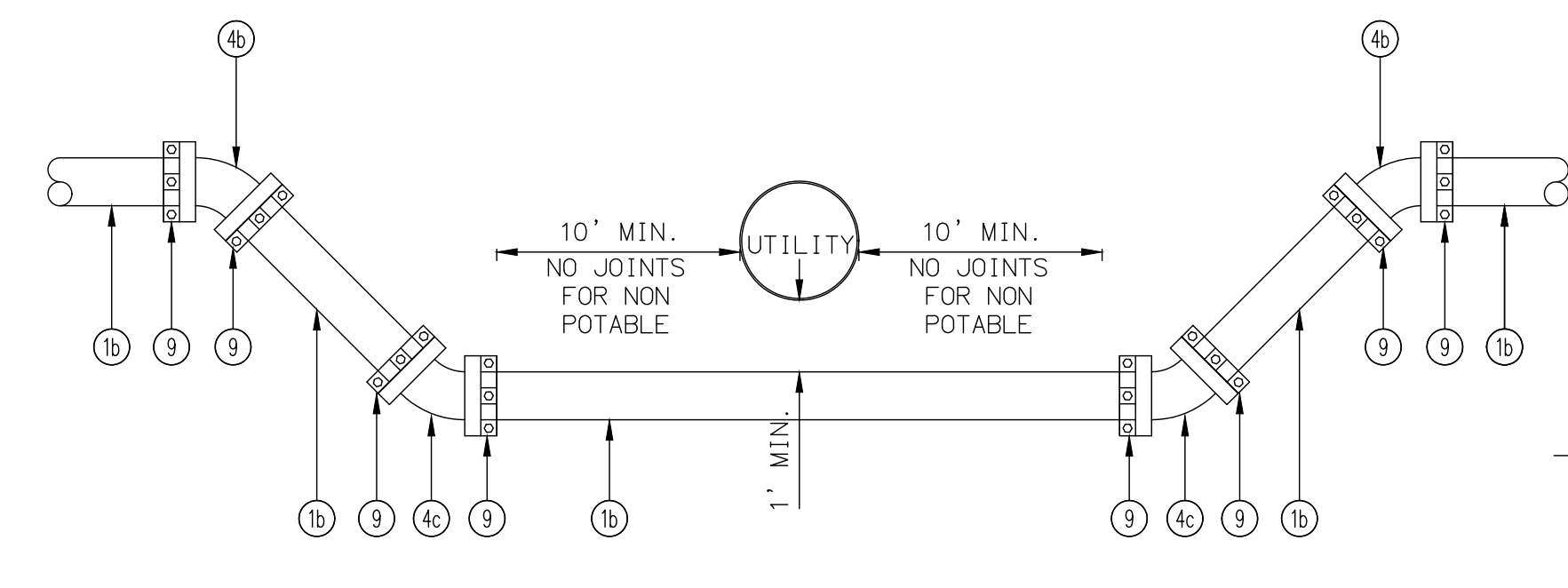

DETAIL "L" CONNECTION
NOT TO SCALE

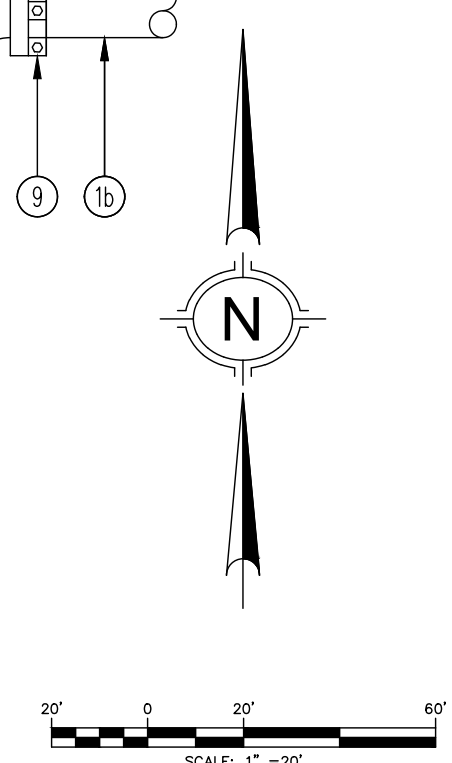

NO WORK SHALL BE DONE ON THIS SITE UNTIL BELOW AGENCY IS NOTIFIED OF INTENTION TO GRADE OR EXCAVATE.

Know what's below.
Call before you dig.

TWO WORKING DAYS BEFORE YOU DIG

ONWARD ENGINEERING

300 S. HARBOR BLVD., SUITE 814
ANAHEIM, CA. 92805
P: (714) 533-3050
F: (714) 808-1270
ONWARDENGINEERING.COM

NO.	DATE	BY	DESCRIPTION	APPROVED
R E V I S I O N S				

PREPARED UNDER THE SUPERVISION OF:

Justin Smeets
JUSTIN SMEETS, PE
R.C.E. NO. 78314, EXP 09/30/23

8/31/2023
DATE

APPROVED BY:

SAM SAMPAT, P.E.
SENIOR CIVIL ENGINEER

DATE

ENGINEERING DIVISION

WATER MAIN REPLACEMENT

247TH STREET AREA

246TH STREET TO WESTERN AVENUE

PROJECT NO. 2021-1-WA

SHT 8 OF 21 SHTS

DESIGNED BY: R. DENNIS
DRAWN BY: R. DENNIS
CHECKED BY: J. SMEETS
PROJECT NO. 2021-1-WA
SHT 8 OF 21 SHTS

Sep 05, 2023 - 2:44pm - C:\Users\JustinSmeets\Box\Projects\Design\Lomita-247th Street Area Water Main Replacement Project\Design\CAD\Drawn\8 246 St.dwg

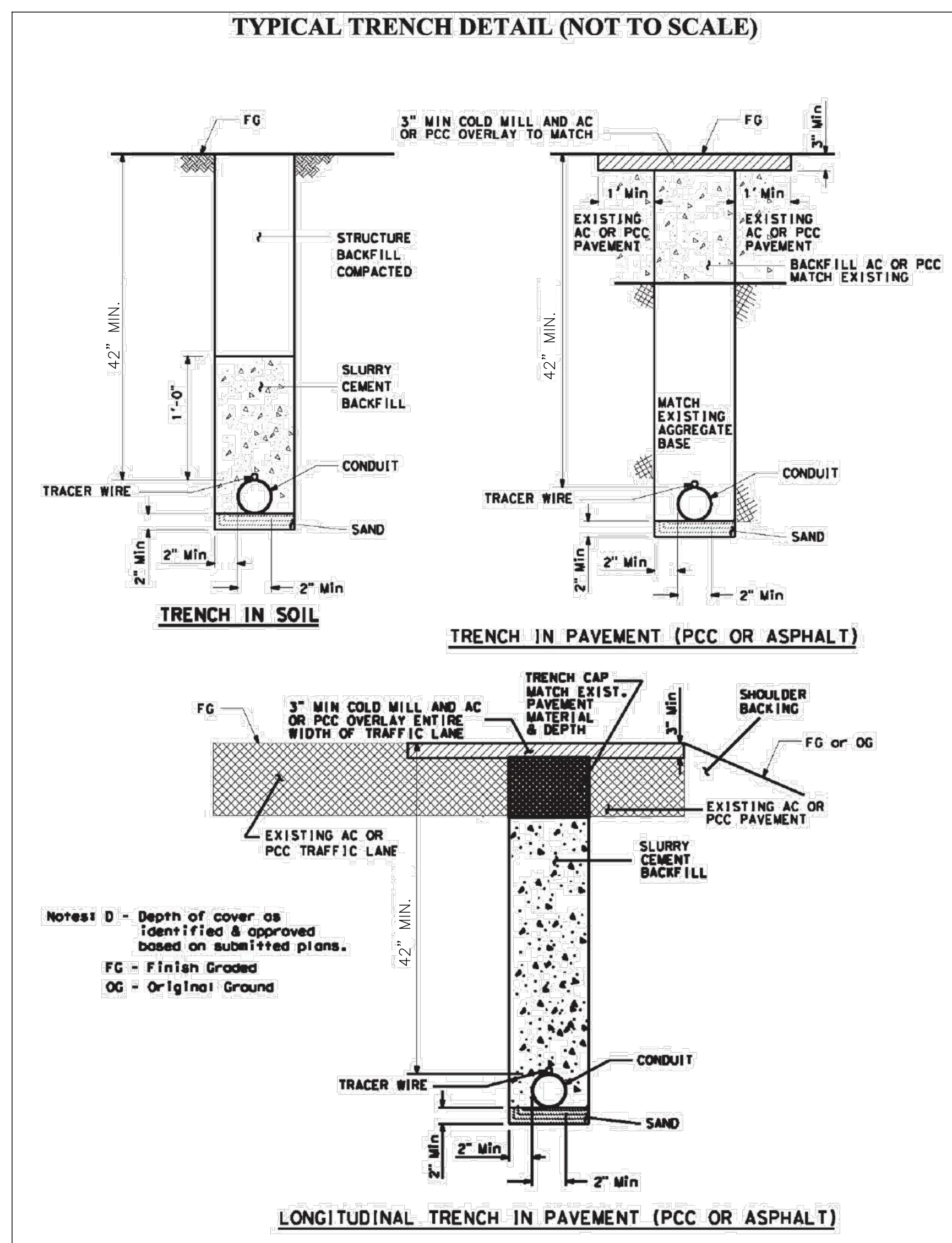

NOTES TO CONTRACTOR

- ALL WORK MUST BE AUTHORIZED BY THE ENCROACHMENT PERMIT, AND/OR AS DIRECTED BY THE STATE'S REPRESENTATIVE.
- ALL TRACER WIRE MUST BE PLACED ON TOP OF THE CONDUIT UNLESS SPECIFIED NOT TO.
- CLEARANCE BETWEEN THE TRENCH WALL AND ENCROACHMENT WORK LESS THAN 6 INCHES IN WIDTH SHALL BE A MINIMUM OF 2 INCHES. CLEARANCE BETWEEN THE TRENCH WALL AND ENCROACHMENT WORK GREATER THAN 6 INCHES WIDTH SHALL BE A MINIMUM 6 INCHES.
- WHEN THE TRENCH WIDTH IS LESS THAN 2' THE BACKFILL FOR SUBGRADE MUST CONSIST OF EITHER SLURRY CEMENT OR CONTROLLED LOW-STRENGTH MATERIAL (CLSM).
- WHEN TRENCH WIDTH IS GREATER THAN 2' COMPACTED AGGREGATE BASE MAY BE USED FOR BACKFILL.
- STRUCTURE BACKFILL MUST CONFORM TO SECTION 19-3.02C OF THE STANDARD SPECIFICATIONS.
- FOR TRENCH LOCATED UNDER UNIMPROVED SURFACE, STRUCTURE BACKFILL CAN USE THE ORIGINAL SOIL. SOIL MUST BE COMPACTED BY MECHANICAL MEANS. PONDING, JETTING OR FLOODING ARE NOT ALLOWED. SLURRY CEMENT BACKFILL IS OPTIONAL AT THE DISCRETION OF THE CALTRANS DISTRICT.
- SLURRY CEMENT BACKFILL MUST CONFORM TO SECTION 19-3.03E OF THE STANDARD SPECIFICATIONS.
- AGGREGATE BASE SHALL CONFORM TO SECTION 26 OF THE STANDARD SPECIFICATIONS.
- CLSM MUST CONFORM TO SECTION 19-3.02G OF THE STANDARD SPECIFICATIONS. WHEN CLSM IS UTILIZED THE MIX DESIGN AND TEST RESULTS MUST BE SUBMITTED TO THE STATE'S REPRESENTATIVE. SEE APPENDIX H OF THE ENCROACHMENT PERMITS MANUAL FOR ADDITIONAL INFORMATION.
- COLD PLANED SURFACE AND OVERLAY SHALL BE TO THE NEAREST LANE LINE FOR THE ENTIRE LENGTH OF THE TRENCH/DISTURBED AREAS, AND/OR AS DIRECTED BY THE STATE'S REPRESENTATIVE.
- A PAVING NOTCH ("T-CUT") SHALL BE COLD PLANED IN EXIST ASPHALT CONCRETE TO A MINIMUM WIDTH OF 1.0' BEYOND EACH SIDE OF THE TRENCH AND TO A DEPTH OF 3" FOR THE FINAL LAYER OF HMA.
- HMA OR PCC TO REPLACE PAVEMENT SECTION SHALL MATCH EXISTING PAVEMENT DEPTH, UNLESS DIRECTED OTHERWISE BY THE STATE'S REPRESENTATIVE.
- HOT MIX ASPHALT MUST CONFORM TO CALTRANS SPECIFICATION SECTION 39.
- A TACK COAT OF ASPHALTIC EMULSION CONFORMING TO CALTRANS SPECIFICATION SECTION 39-2.01C (3) (f) SHALL BE APPLIED.
- WHEN THE TRENCH IS WITHIN 4' OF CURB AND GUTTER, ADDITIONAL COLD PLANING MAY BE REQUIRED AT THE DISCRETION OF THE STATE'S REPRESENTATIVE.
- PAVEMENT MARKINGS AND/OR STRIPING REMOVED OR DAMAGED DURING CONSTRUCTION MUST BE REPLACED AS DIRECTED BY THE STATE'S REPRESENTATIVE.
- OTHER TRENCH RELATED DETAILS ARE SHOWN IN CHAPTER 6 OF THE ENCROACHMENT PERMITS MANUAL AS WELL AS THE TRENCHING AND SHORING MANUAL. BOTH PUBLICATIONS CAN BE FOUND ON THE STATE OF CALIFORNIA, DEPARTMENT OF TRANSPORTATION'S WEBSITE.

TYPICAL TRENCH DETAIL IN CALTRANS RIGHT-OF-WAY
NOT TO SCALE

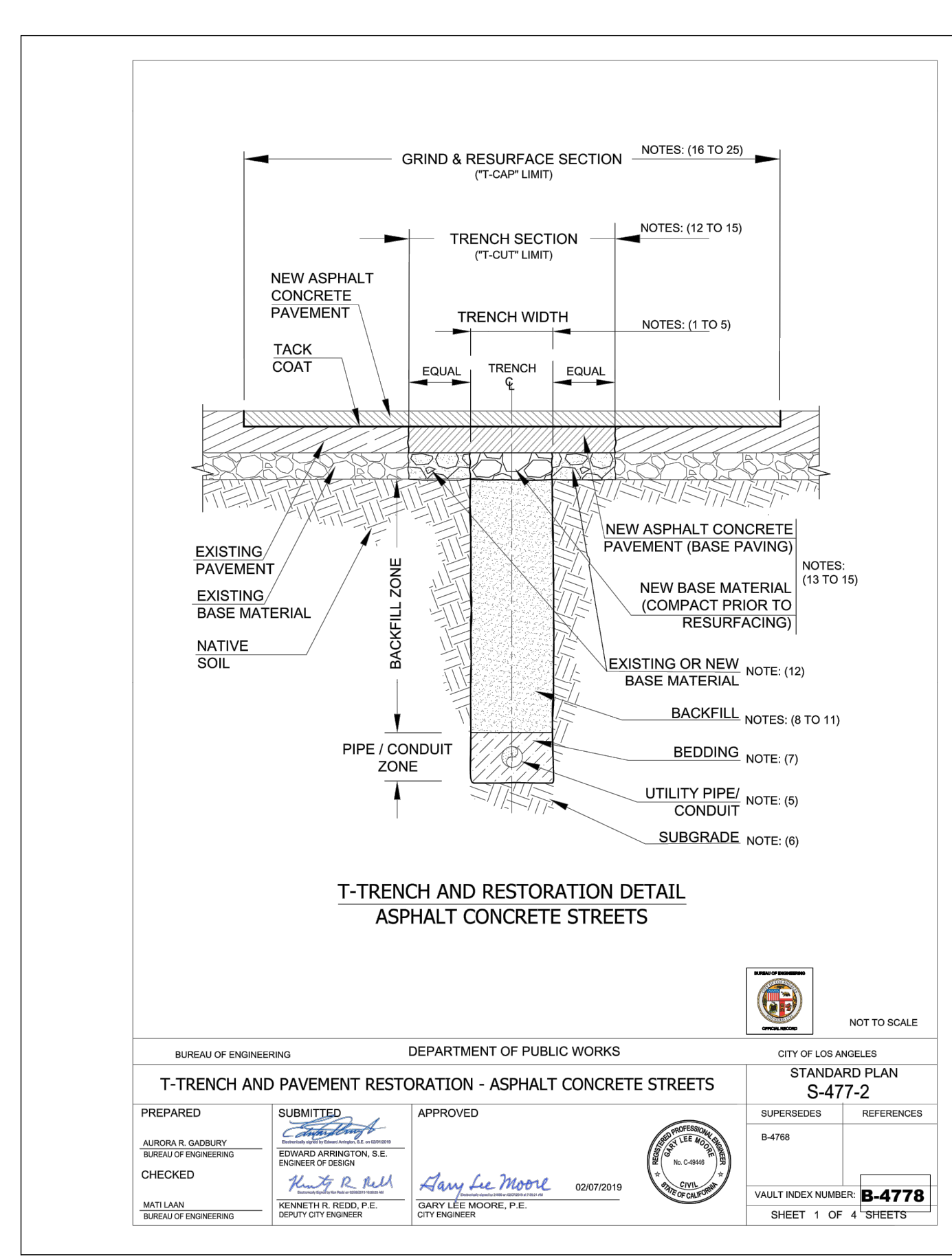

- NOTES:**
- ALL WORK SHALL BE CONSTRUCTED IN ACCORDANCE WITH THE LATEST STANDARD SPECIFICATIONS FOR PUBLIC WORKS CONSTRUCTION (SSPWC) "GREENBOOK" ADOPTED BY THE BOARD OF PUBLIC WORKS AS AMENDED BY THE LATEST CORRESPONDING CITY OF LOS ANGELES DEPARTMENT OF PUBLIC WORKS "BROWNBOOK".
- LIMITS OF REMOVALS, TRENCH WIDTH:**
- ALL PAVEMENT REMOVED SHALL HAVE STRAIGHT EDGES. CUTS SHALL BE MADE TO A MINIMUM DEPTH OF ONE AND A HALF (1-1/2) INCHES. ALL CUTS SHALL BE NEAT, STRAIGHT, VERTICAL CUTS WITH NO BROKEN EDGES.
 - ALL LONGITUDINAL PAVEMENT CUTS SHALL BE UNINTERRUPTED APPROXIMATELY PARALLEL TO THE TRENCH (MAX. 1% LONGITUDINAL VARIANCE).
 - IF A SAW CUT IN PAVEMENT FALLS WITHIN 1 FOOT OF AN EXISTING CURB, GUTTER, OR EDGE OF PAVEMENT, THE ADDITIONAL PAVEMENT SHALL BE REMOVED AND RECONSTRUCTED.
 - WHEN SAW CUTTING PAVEMENT, THE MAXIMUM OVERRUN ALLOWED FOR ANY SAW CUT BEYOND THE BOUNDARY REMOVAL LIMITS OF EXISTING PAVEMENT SHALL BE 2 INCHES.
 - TRENCH WIDTH SHALL BE MINIMUM 24 INCHES, UNLESS SLURRY BACKFILL AND BEDDING IS USED, IN WHICH CASE MINIMUM SHALL BE 4 INCHES. MINIMUM 3 INCH SEPARATION SHALL BE MAINTAINED BETWEEN ALL CONDUITS, PIPES, AND TRENCH WALLS. IF SLURRY BEDDING MATERIAL IS USED, 1 INCH IS ACCEPTABLE IN A SINGLE LAYER INSTALLATION, OTHERWISE 2 INCH SEPARATION IS REQUIRED. UNDERCUTTING TRENCH WALLS TO ACQUIRE CLEARANCES IS NOT PERMITTED.
- BEDDING:**
- BEDDING MATERIAL SHALL BE PLACED ON FIRM AND UNYIELDING SUBGRADE PER GREENBOOK SECTION 306. SOFT, SPONGY, UNSTABLE, UNSUITABLE MATERIAL SHALL BE REMOVED AND REPLACED.
 - BEDDING SHALL CONFORM TO GREENBOOK REQUIREMENTS AND OTHER APPLICABLE STANDARDS.
- BACKFILL:**
- EXCAVATIONS SHALL BE BACKFILLED WITH AN APPROVED SLURRY MIX, CLSM, CMB, OR CAB. NATIVE SOIL MAY ONLY BE USED WITH CITY ENGINEER'S APPROVAL. CMB, CAB, SOIL SHALL BE COMPACTED TO 95% RELATIVE DENSITY. CMB, CAB SHALL BE WELL GRADED AND HANDLED IN A MANNER TO PREVENT SEGREGATION BY PARTICLE SIZE. SOIL TESTING MAY BE REQUIRED TO BE PROVIDED TO THE FIELD INSPECTOR ON A CASE-BY-CASE BASIS.
 - BACKFILL SLURRY MATERIAL SHALL BE PROPERLY CONSOLIDATED. SLURRY MATERIAL FOR TRENCHES DEEPER THAN 5 FEET AND/OR NARROWER THAN 12 INCHES SHALL BE CONSOLIDATED WITH VIBRATION.
 - BACKFILL MATERIAL SHALL BE MADE SMOOTH AND LEVEL BEFORE PLACING BASE AND PAVEMENT.
 - JETTING IS NOT AN APPROVED DENSIFICATION METHOD.
- TRENCH SECTION:**
- AFTER THE EXCAVATION HAS BEEN BACKFILLED, THE EXISTING PAVEMENT SHALL BE REMOVED TO A LINE AT LEAST 12-INCHES BACK OF THE FIRM BANKS OF THE TRENCH ("T-CUT"). EXISTING CMB OR CAB BASE MATERIAL IN THIS AREA SHALL BE COMPACTED TO 95% RELATIVE DENSITY AND NEW BASE MATERIALS SHALL BE PROVIDED TO MATCH THE SURROUNDING BASE THICKNESS AS NECESSARY. WHERE NO BASE MATERIAL EXISTS IN THIS AREA, THE NEW BASE MATERIAL SHALL EXTEND BEYOND THE TRENCH WIDTH TO COVER THE ENTIRE TRENCH "T-CUT" AREA.

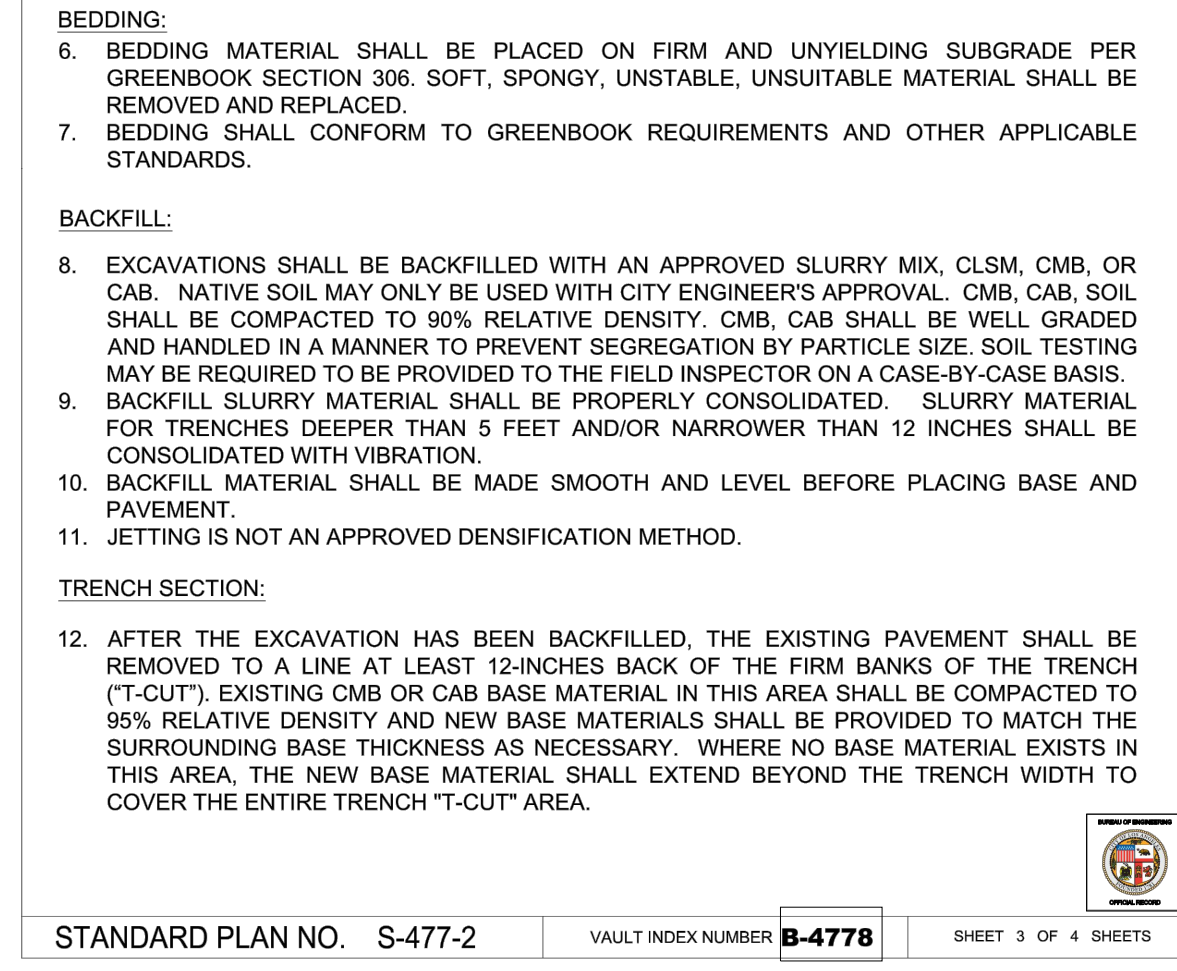

TYPICAL TRENCH DETAIL IN CITY OF LOS ANGELES RIGHT-OF-WAY
NOT TO SCALE

- NOTES: (CONTINUED)**
- NEW BASE MATERIAL OF CMB, OR CAB, SHALL MATCH THE EXISTING BASE THICKNESS, OR 4-INCHES, WHICHEVER IS GREATER AND SHALL BE COMPACTED TO 95% RELATIVE DENSITY. THIS REQUIREMENT SHALL ALSO APPLY OVER SLURRY BACKFILLS UNLESS OTHERWISE APPROVED BY THE ENGINEER. "T-CUT" IS NOT REQUIRED IF AN APPROVED SLURRY MIX BACKFILL IS USED, UNLESS UNDERMINING OF ADJACENT PAVEMENT IS PRESENT. IF SLURRY TRENCH WIDTH IS LESS THAN 12 INCHES, EXISTING PAVEMENT SHALL BE REMOVED TO PROVIDE AT LEAST A 12 INCH WIDE TRENCH SECTION FOR PROPER COMPACTION OF THE BASE MATERIAL.
 - NEW ASPHALT CONCRETE SECTION SHALL MATCH EXISTING PAVEMENT THICKNESS, OR 6 INCHES, WHICHEVER IS GREATER.
 - ASPHALT CONCRETE PAVING WILL OCCUR NO SOONER THAN 42 HOURS AFTER SLURRY BACKFILL OF THE BASE MATERIAL.
- GRIND AND RESURFACE SECTION:**
- WITHIN 30 CALENDAR DAYS AFTER BACKFILLING, ASPHALT CONCRETE SHALL BE COLD MILLED AND RESURFACED AS FOLLOWS:
- EXISTING ASPHALT CONCRETE SHALL BE GROUND DOWN ONE AND ONE HALF (1-1/2) INCHES, OR ONE HALF THE EXISTING PAVEMENT THICKNESS, WHICHEVER IS LESS, TO THE "T-CAP" LIMITS.
 - WHERE POSSIBLE, "T-CAP" LIMITS SHALL BE FROM FIGURE 1, "EXAMPLES OF GRIND AND RESURFACE "T-CAP" LIMITS". "T-CAP" IS NOT REQUIRED IN STREETS THAT HAVE NOT BEEN RESURFACED WITHIN THE PAST 8 YEARS AND DO NOT IMPACT BIKE LANES.
 - "T-CAP" LIMITS SHALL EXTEND AT LEAST 2 FEET BEYOND THE TRENCH SECTION ("T-CUT" LIMITS). MINIMUM "T-CAP" DIMENSIONS SHALL BE 5 FEET X 5 FEET.
 - "T-CUT" AND CORRESPONDING "T-CAP" (AS APPLICABLE) IS REQUIRED FOR ALL EXCAVATIONS WITH A SURFACE AREA OF 3 SQ. FT OR GREATER.
 - WHERE LIMITS OF "T-CUTS", "T-CAPS", POT HOLES OR CORED HOLES ARE WITHIN 4FT OF EACH OTHER, THE PAVEMENT SURFACE RESTORATION SHALL BE COMBINED, BLENDED AND SQUARED USING "T-CAPS" TO ENCOMPASS ALL AREAS IN BETWEEN AS SHOWN IN FIGURE 1. "T-CAP" LIMITS FOR POT HOLES AND CORE HOLES SHALL EXTEND A MINIMUM OF 1-FOOT ALL AROUND BEYOND THE HOLES.
 - IMPACTED BIKE LANES - "T-CAP" LIMITS SHALL FULLY ENCOMPASS ANY BIKE LANE IMPACTED BY THE TRENCH, AND SHALL HAVE A MINIMUM THAT EXTENDS AT LEAST 2 FEET BEYOND THE ASPHALT REMOVAL LIMITS IN THE DIRECTION OF BIKE TRAFFIC.
 - WHEN THE "T-CAP" LIMIT IS WITHIN 2 FEET OR LESS FROM A CURB OR GUTTER, THE "T-CAP" LIMIT SHALL EXTEND TO THE CURB OR GUTTER.
 - PAVEMENT SHALL BE LEVEL WITH ADJACENT ROADWAY ELEVATIONS AND SHALL PROVIDE A SMOOTH SURFACE PER GREENBOOK SECTION 392-5 AND SUBJECT TO ACCEPTANCE BY THE CITY PUBLIC WORKS INSPECTOR.
 - "T-CAP" AND PERMANENT BASE PAVING MAY BE PERFORMED ON THE SAME DAY WHEN FEASIBLE.
- IDENTIFICATION:**
- EACH RESURFACING SHALL BE IDENTIFIED WITH A METAL IDENTIFICATION TAG IDENTIFYING THE OWNER, AND YEAR OF CONSTRUCTION. IF THE RESURFACING IS MORE THAN 50 FEET IN LENGTH, PLACE THE TAG NEAR EACH END OF THE RESURFACING AND AT INTERVALS NOT TO EXCEED 50 FEET.

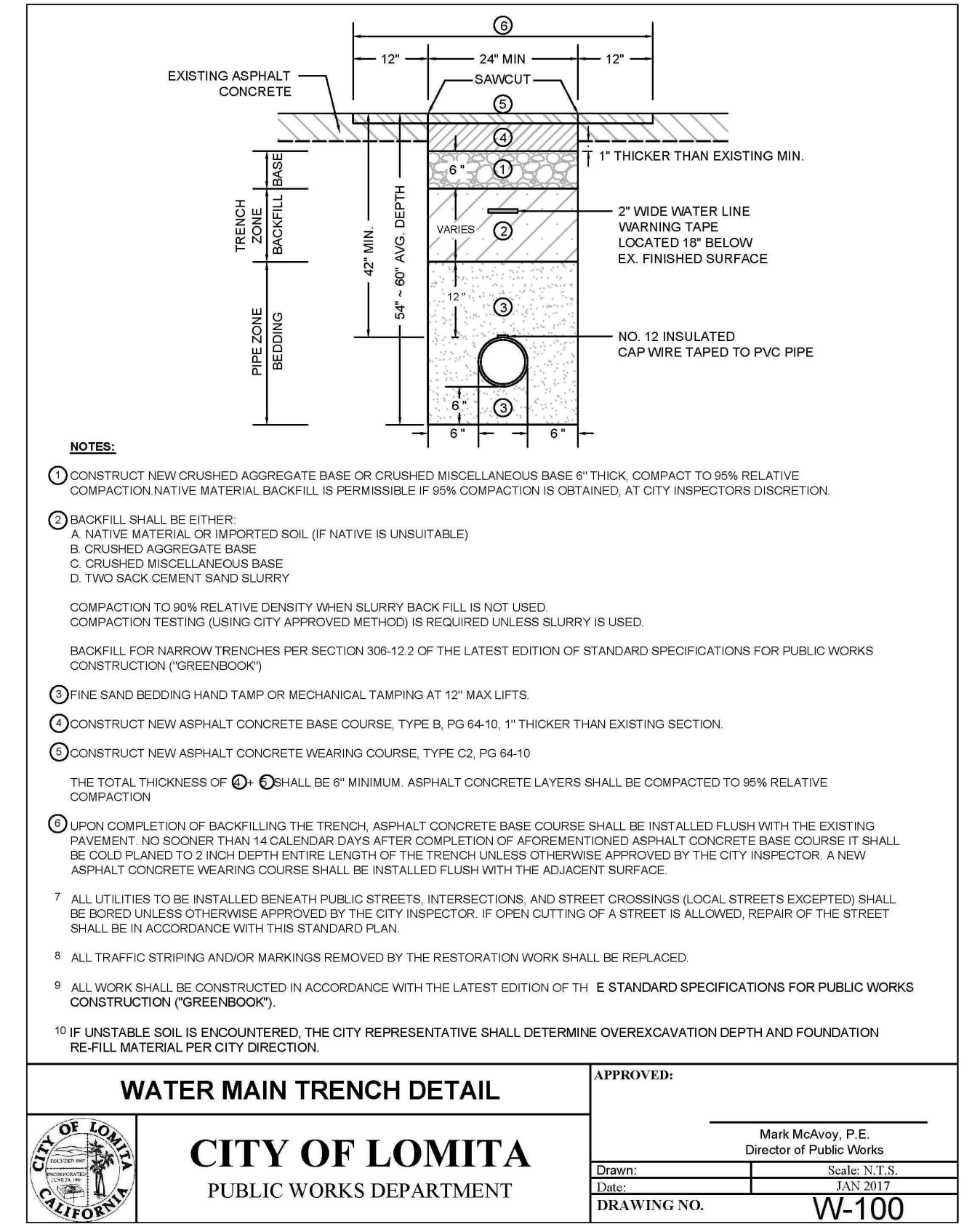
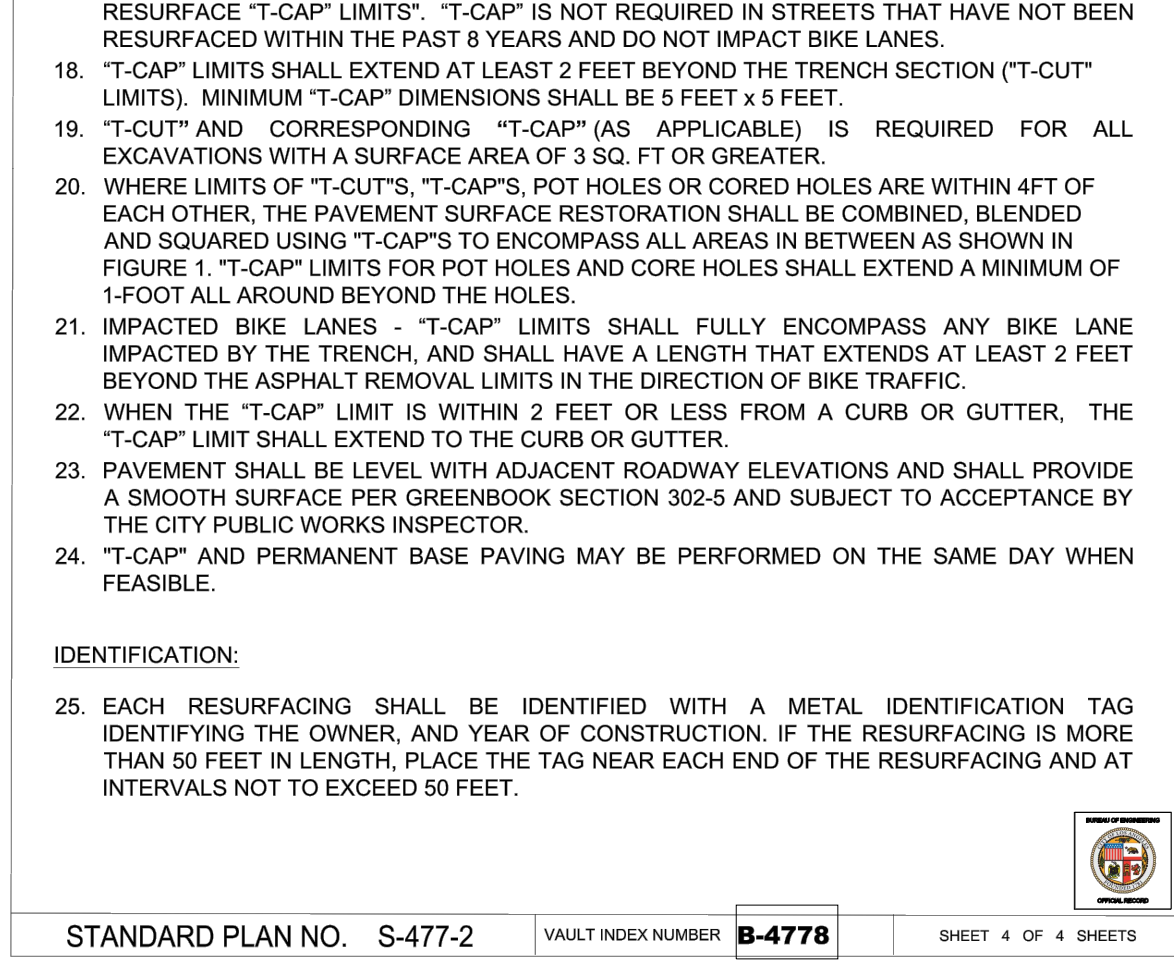

TYPICAL TRENCH DETAIL IN CITY OF LOMITA RIGHT-OF-WAY
NOT TO SCALE

CITY OF LOMITA
PUBLIC WORKS DEPARTMENT

APPROVED: Mark McAvoy, P.E. Director of Public Works

DATE: JAN 2017
 DRAWING NO. W-100

NO WORK SHALL BE DONE ON THIS SITE UNTIL BELOW AGENCY IS NOTIFIED OF INTENTION TO GRADE OR EXCAVATE.

811
Know what's below. Call before you dig.
TWO WORKING DAYS BEFORE YOU DIG

ONWARD ENGINEERING
300 S. HARBOR BLVD., SUITE 814
ANAHEIM, CA. 92805
P: (714) 533-3050
F: (714) 808-1270
ONWARDENGINEERING.COM

NO.	DATE	BY	DESCRIPTION	APPROVED
R E V I S I O N S				



PREPARED UNDER THE SUPERVISION OF:
 Justin L. Sweets, P.E.
 R.C.E. NO. 78314, EXP 09/30/23

DATE: 8/31/2023

APPROVED BY: SAM SAMPAT, P.E. SENIOR CIVIL ENGINEER

DATE: _____

ENGINEERING DIVISION

WATER MAIN REPLACEMENT
247TH STREET AREA
TYPICAL TRENCH DETAILS

DESIGNED BY: R. DENNIS
 DRAWN BY: R. DENNIS
 CHECKED BY: J. SWEETS
 PROJECT NO. 2021-1-WA
 SHT 9 OF 21 SHTS

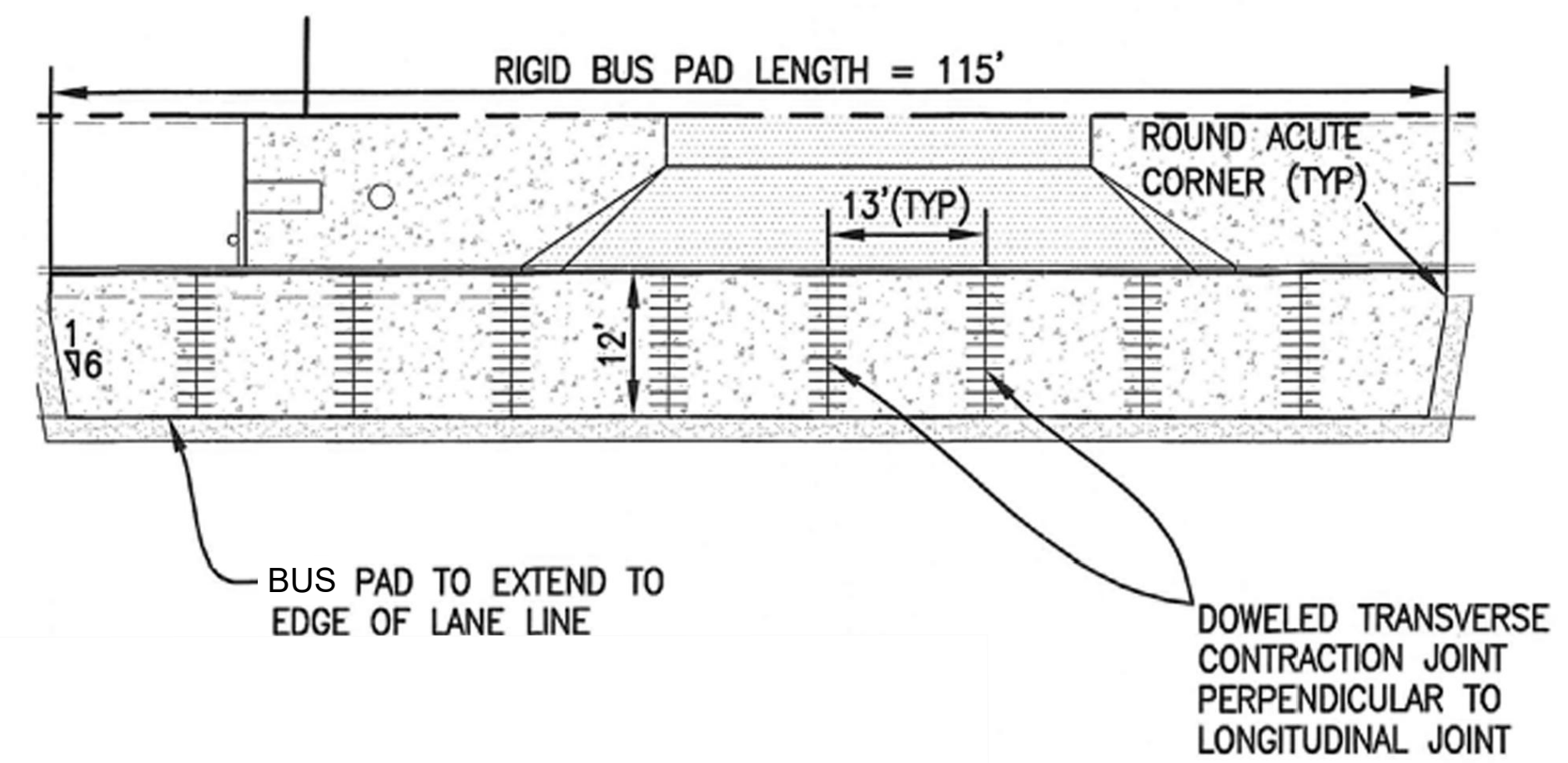
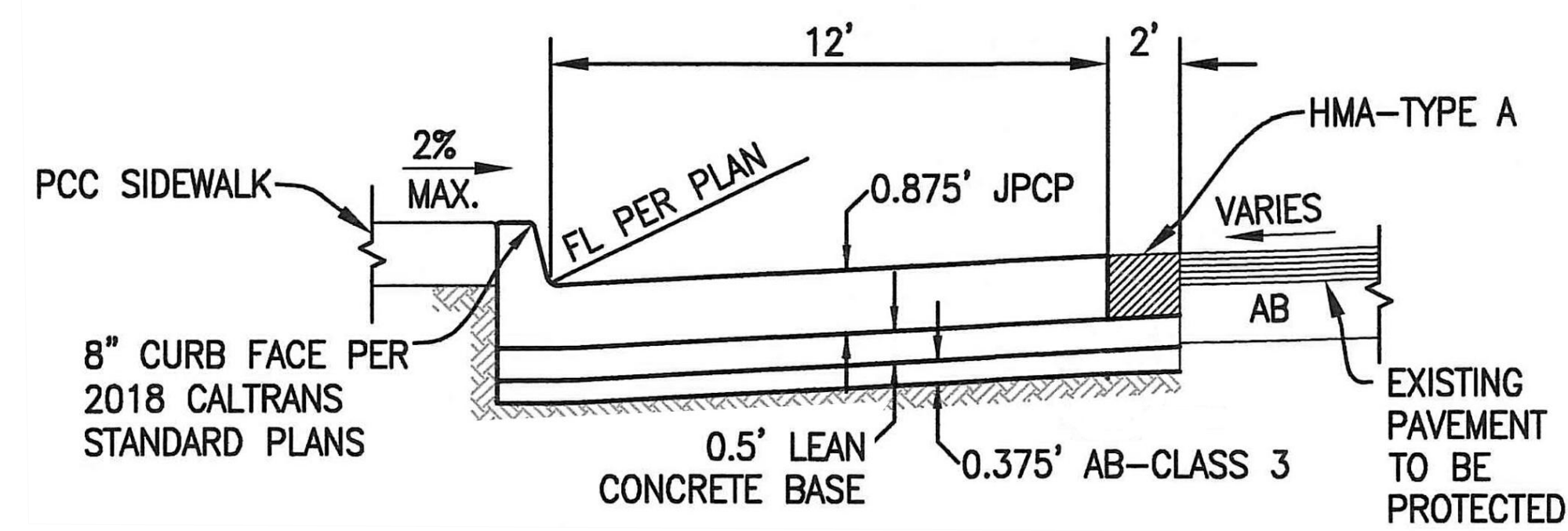

TYPICAL BUS PAD DETAILS
NOT TO SCALE

NO WORK SHALL BE DONE ON THIS SITE UNTIL BELOW AGENCY IS NOTIFIED OF INTENTION TO GRADE OR EXCAVATE.



Know what's below.
Call before you dig.

TWO WORKING DAYS BEFORE YOU DIG

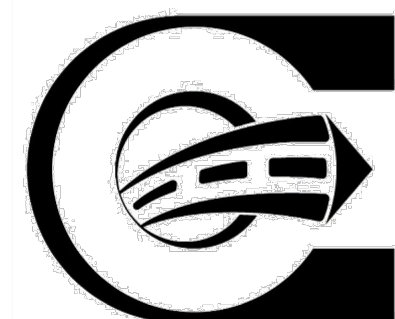

ONWARD ENGINEERING

300 S. HARBOR BLVD., SUITE 814
ANAHEIM, CA. 92805
P: (714) 533-3050
F: (714) 808-1270
ONWARDENGINEERING.COM

NO.	DATE	BY	DESCRIPTION	APPROVED
R E V I S I O N S				



PREPARED UNDER THE SUPERVISION OF:

Justin Smeets
JUSTIN SMEETS, P.E.
R.C.E. NO. 78314, EXP 09/30/23

8/31/2023
DATE

APPROVED BY:

SAM SAMPAT, P.E.
SENIOR CIVIL ENGINEER

DATE

ENGINEERING DIVISION

WATER MAIN REPLACEMENT

247TH STREET AREA

TYPICAL BUS PAD DETAILS

PROJECT AND SHEET TITLE

DESIGNED BY:

R. DENNIS

DRAWN BY:

R. DENNIS

CHECKED BY:

J. SMEETS

PROJECT NO.

2021-1-WA

SHT 10 OF 21 SHTS

GENERAL NOTES - TRAFFIC CONTROL

- IT IS THE RESPONSIBILITY OF THE CONTRACTOR PERFORMING WORK ON A PUBLIC STREET TO INSTALL AND MAINTAIN THE TRAFFIC CONTROL DEVICES AS SHOWN HEREIN, AS WELL AS ANY SUCH ADDITIONAL TRAFFIC CONTROL DEVICES AS MAY BE REQUIRED TO ENSURE THE SAFE MOVEMENT OF TRAFFIC AND PEDESTRIANS THROUGH OR AROUND THE WORK AREA AND PROVIDE MAXIMUM PROTECTION AND SAFETY TO CONSTRUCTION WORKERS.
- ALL DELINEATORS SHALL BE EQUIPPED WITH REFLECTIVE BAND AT NIGHT TIME
- THE CONTRACTOR SHALL NOTIFY CALTRANS AND CITY OF LOMITA AT LEAST FIVE WORKING DAYS IN ADVANCE OF IMPLEMENTING ANY CONSTRUCTION DETOUR.
- ALL SIGNS, DELINEATORS, BARRICADES, ETC. AND THEIR INSTALLATION SHALL CONFORM TO THE STATE OF CALIFORNIA STANDARD SPECIFICATIONS LATEST EDITION, THE CALIFORNIA MANUAL ON UNIFORM TRAFFIC CONTROL DEVICES (MUTCD) LATEST EDITION AND THE WORK AREA TRAFFIC CONTROL HANDBOOK (WATCH, LATEST EDITION ON THE CITY STREETS).
- CALTRANS AND CITY OF LOMITA RESERVE THE RIGHT TO OBSERVE THESE TRAFFIC CONTROL PLANS IN USE AND TO MAKE ANY NECESSARY CHANGES AS FIELD CONDITIONS WARRANT. ANY CHANGES SHALL SUPERSEDE THESE PLANS AND BE DONE PER MUTCD WITH THE APPROVAL OF CITY/CALTRANS ENGINEER. REVISED TRAFFIC CONTROL PLANS MAY BE REQUIRED BY CITY/CALTRANS. EXACT LOCATION OF ALL EQUIPMENT AND TRAFFIC CONTROL DEVICES SHALL BE DETERMINED BY THE ENGINEER.
- CONTRACTOR SHALL NOTIFY MTA, TORRANCE TRANSIT AND MAX OR ANY OTHER AFFECTED TRANSIT SERVICES AT LEAST FIVE WORKING DAYS PRIOR TO CONSTRUCTION.
- ALL TRAFFIC CONTROL DEVICES, STRIPES, MARKINGS, LEGENDS, AND RAISED PAVEMENT MARKERS SHALL CONFORM TO MUTCD, CALTRANS STANDARD PLANS, AND STANDARD SPECIFICATIONS (MOST RECENT EDITION).
- ALL TRAFFIC CONTROL DEVICES SHALL BE KEPT IN THEIR PROPER POSITION AT ALL TIMES, AND SHALL BE REPAIRED, REPLACED, OR CLEANED AS NECESSARY TO PRESERVE THEIR APPEARANCE AND CONTINUITY.
- ALL TRAFFIC LANES SHALL HAVE A MINIMUM OF 5 FEET CLEARANCE FROM OPEN EXCAVATIONS AND A MINIMUM OF 2 FEET FROM VERTICAL OBSTRUCTIONS.
- CONTRACTOR SHALL PROVIDE FLAGGERS AS DEEMED NECESSARY BY ENGINEER.
- CONTRACTOR SHALL NOTIFY ALL AFFECTED RESIDENTS AND BUSINESSES FIVE WORKING DAYS PRIOR TO CONSTRUCTION.
- ALL ADVANCED WARNING SIGNS SHALL BE EQUIPPED WITH FLAGS DURING DAYTIME WORKING HOURS AND WITH WARNING LIGHTS AT NIGHT.
- TRAFFIC SIGNALS SHALL REMAIN IN OPERATION AT ALL TIMES. CONFLICTING TRAFFIC SIGNAL INDICATIONS SHALL BE COVERED AND SIGNAL OPERATION DURING EACH CONSTRUCTION PHASE SHALL BE COORDINATED WITH AND APPROVED BY THE CITY/CALTRANS ENGINEER.
- PLACE ADDITIONAL "LANE CLOSED" (C30) SIGNS ON TYPE II BARRICADES AT 150 FOOT INTERVALS THROUGH EXTENDED WORK AREA IN EACH LANE THAT IS CLOSED. INSTALL "OPEN TRENCH" (C27) SIGNS WHENEVER AN OPEN EXCAVATION EXISTS ADJACENT TO THE TRAVELED WAY WITHIN CONSTRUCTION ZONE.
- ALL TEMPORARY TRAFFIC CONTROL DEVICES SHALL BE REMOVED FOLLOWING COMPLETION OF EACH CONSTRUCTION STAGE AND THE PERMANENT TRAFFIC CONTROL DEVICES SHALL BE RESTORED BY THE CONTRACTOR AT THE END OF EACH WORK DAY.
- CONTRACTOR SHALL REPLACE/REPAIR ALL DAMAGED STRIPING WITH TEMPORARY STRIPING OR RAISED PAVEMENT MARKERS AT END OF EACH WORKING DAY.
- CONTRACTOR SHALL COMPLY WITH THE REQUIREMENTS OF THE AMERICAN DISABILITY ACT ACCESSIBILITY GUIDELINES AND WITH THE CALIFORNIA ACCESSIBILITY GUIDELINES AS RELATED TO PEDESTRIAN ACCESS AND SHALL MAINTAIN PEDESTRIAN ACCESS AT ALL TIMES PER ADA REQUIREMENTS. SIDEWALK CLOSURE/DETOUR SHALL COMPLY WITH THE MUTCD STANDARDS.
- CONTRACTOR SHALL COVER OR REMOVE ALL CONFLICTING SIGNS.
- CONTRACTOR SHALL POST "SYMBOL" UNEVEN LANES, "STEEL PLATES AHEAD" OR "BUMP" SIGNS FOR PAVEMENT SURFACE DISRUPTIONS OF 1/2 IN. OR GREATER. PAVEMENT DISRUPTIONS OF 1 IN. OR GREATER SHALL HAVE BEVELED EDGE OF FOUR (4) HORIZONTAL TO ONE (1) VERTICAL.
- CONTRACTOR SHALL INSTALL "CAUTION STEEL PLATES AHEAD" AND/OR "ROUGH ROAD" SIGNS IN ADVANCE OF STEEL PLATE BRIDGING.

CONTRACTOR NOTES

- CONTRACTOR TO MAINTAIN DRIVEWAY ACCESS TO RESIDENTS WHEN NOT DIRECTLY IN AREA.
- NO STREET PARKING DURING CONSTRUCTION HOURS 10 PM TO 5 AM. CONTRACTOR TO NOTIFY RESIDENTS 48 HOURS PRIOR TO CONSTRUCTION ON RESIDENTIAL STREETS. AND ALLEY WAYS.

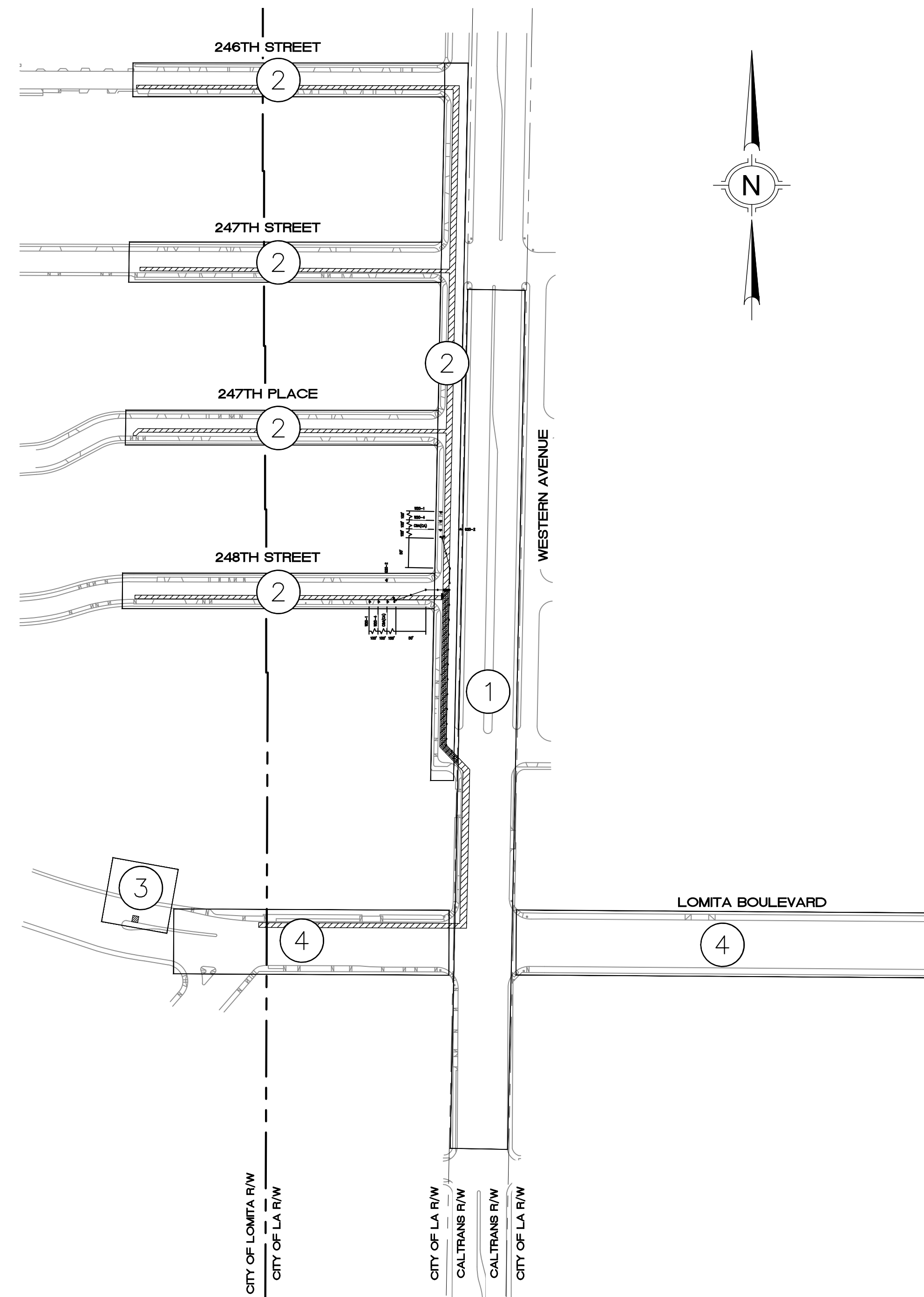

TRAFFIC CONTROL STANDARDS

- CALTRANS MUTCD. SEE SHEETS 14 TO 19.
- CA MUTCD TA-27 - CLOSURE AT THE SIDE OF AN INTERSECTION. SEE SHEET 12.
- LADOT STD. PLAN NO. S-488.1 - MID-BLOCK, RIGHT LANE CLOSURE, NO BIKE LANE. SEE SHEET 13.
- LADOT STD. PLAN NO. S-488.1 - FAR SIDE, RIGHT LANE CLOSURE, NO BIKE LANE. SEE SHEET 13.

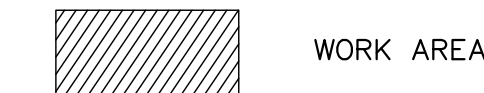

NO WORK SHALL BE DONE ON THIS SITE UNTIL BELOW AGENCY IS NOTIFIED OF INTENTION TO GRADE OR EXCAVATE.

Know what's below. Call before you dig. TWO WORKING DAYS BEFORE YOU DIG

ONWARD ENGINEERING
 300 S. HARBOR BLVD., SUITE 814
 ANAHEIM, CA. 92805
 P: (714) 533-3050
 F: (714) 808-1270
 ONWARDENGINEERING.COM

NO.	DATE	BY	DESCRIPTION	APPROVED
R E V I S I O N S				



PREPARED UNDER THE SUPERVISION OF:

 JUSTIN SMEETS, PE
 R.C.E. NO. 78314, EXP 09/30/23
 DATE 8/31/2023

APPROVED BY:
 SAM SAMPAT, P.E.
 SENIOR CIVIL ENGINEER
 DATE _____
 ENGINEERING DIVISION

WATER MAIN REPLACEMENT
 247TH STREET AREA

TRAFFIC CONTROL PLAN
 GENERAL NOTES

PROJECT AND SHEET TITLE

DESIGNED BY : R. DENNIS
DRAWN BY : R. DENNIS
CHECKED BY : J. SMEETS
PROJECT NO. 2021-1-WA
SHT 11 OF 21 SHTS

Sep 05, 2023 - 2:44pm - C:\Users\JustinSmeets\Box\Projects\Design\247th Street Area Water Main Replacement Project\Design\CAD\Plans\11 Traffic Control - General Notes.dwg

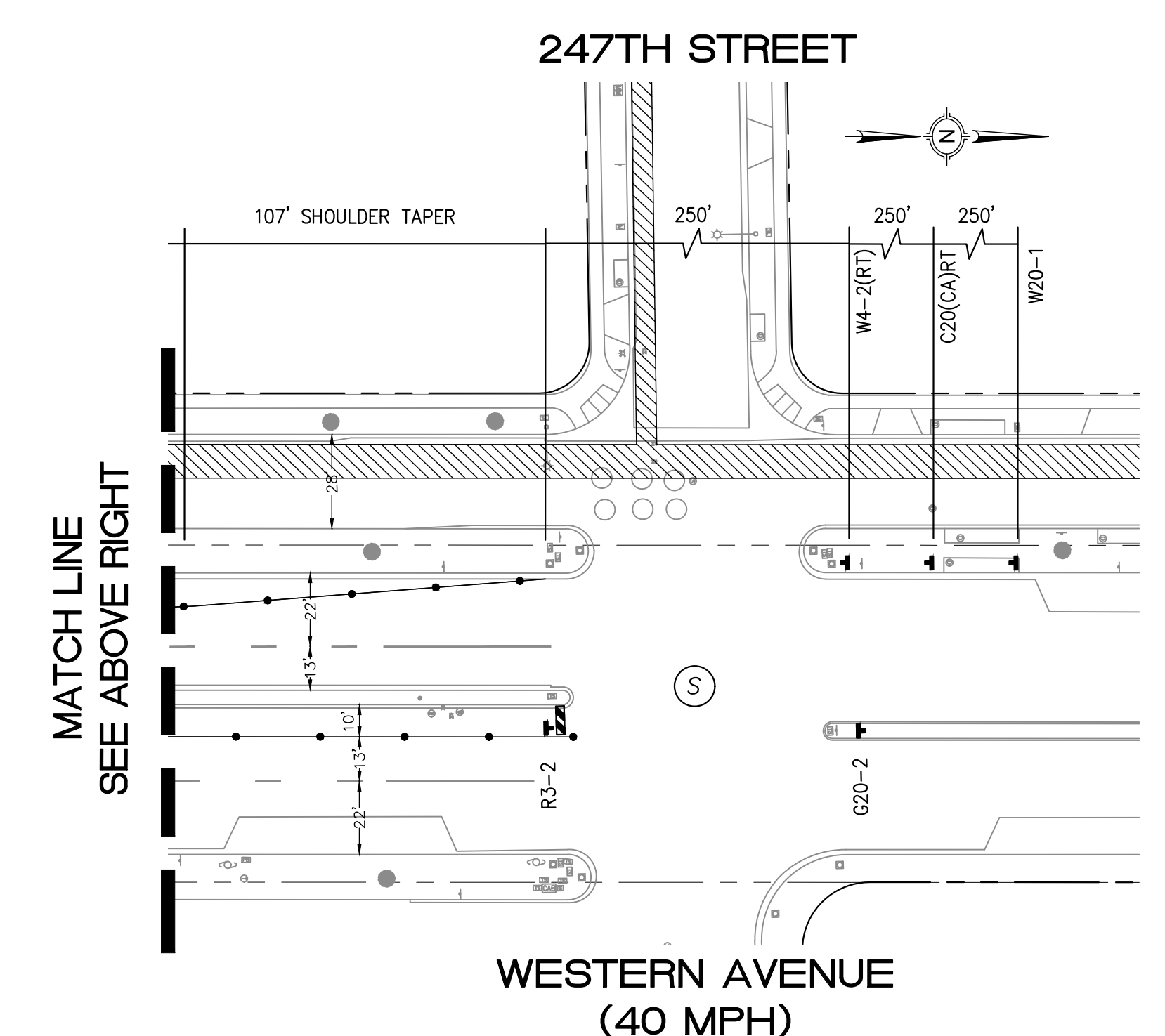
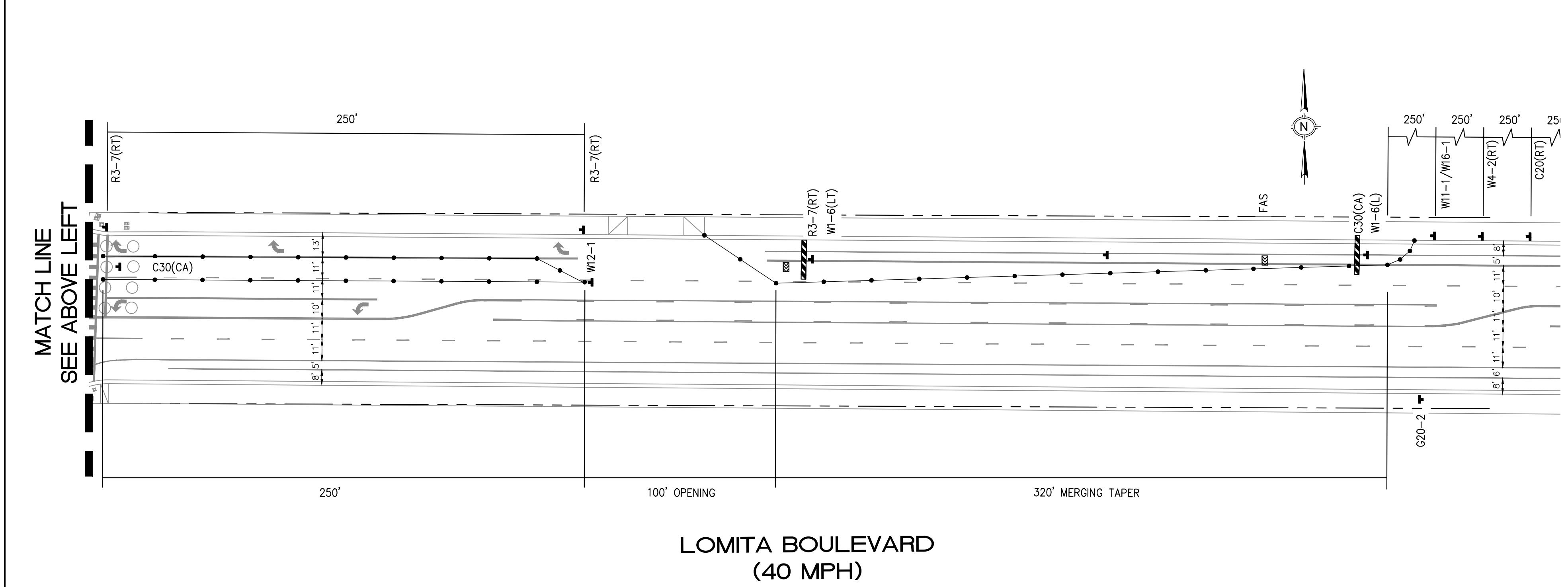
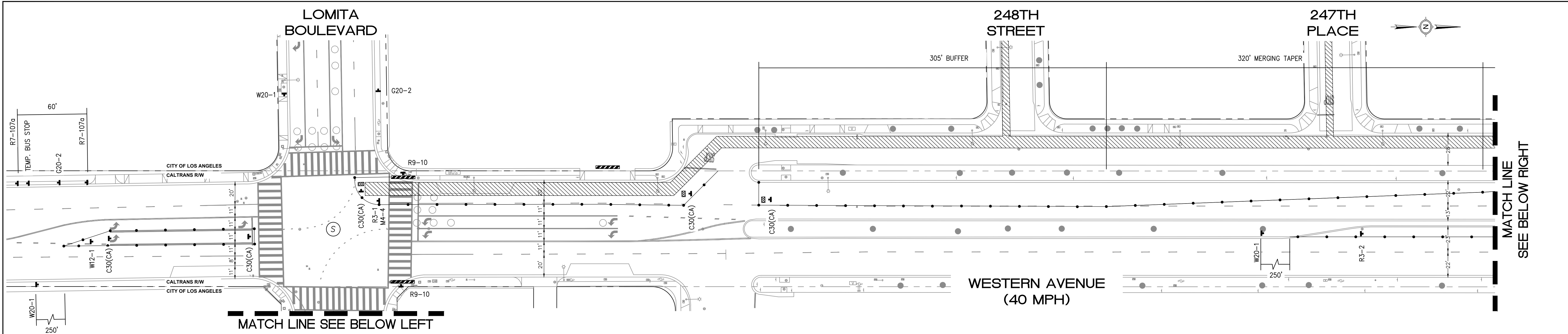

LEGEND:

- PORTABLE DELINEATOR (28" MIN.)
- W20-1+ TEMPORARY CONSTRUCTION SIGN (OF TYPE INDICATED)
- ▨ TYPE II BARRICADE WITH SIGN MOUNTED ON BARRICADE (IF SHOWN)
- ▨ CONSTRUCTION AREA
- ▨ FLASHING ARROW SIGN
- Ⓢ SIGNALIZED INTERSECTION
- ◆ ONE RIGHT LANE CLOSED AHEAD
- ◆ LANE CLOSED
- ▭ END ROAD WORK
- ⊘ R3-1
- ⊘ R3-2
- ▭ RIGHT LANE MUST TURN RIGHT
- Ⓡ R7-107a
- ▭ SIDEWALK CLOSED CROSS HERE
- ▭ TRUCK
- ▭ ←
- ◆ W4-2 (RT)
- ◆ W12-1
- ◆ ROAD WORK AHEAD

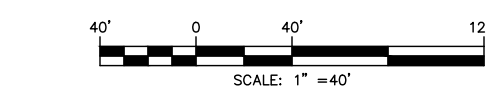

NO WORK SHALL BE DONE ON THIS SITE UNTIL BELOW AGENCY IS NOTIFIED OF INTENTION TO GRADE OR EXCAVATE.

811
Know what's below.
Call before you dig.
TWO WORKING DAYS BEFORE YOU DIG

ONWARD ENGINEERING
300 S. HARBOR BLVD., SUITE 814
ANAHEIM, CA. 92805
P: (714) 533-3050
F: (714) 808-1270
ONWARDENGINEERING.COM

NO.	DATE	BY	DESCRIPTION	APPROVED
R E V I S I O N S				



PREPARED UNDER THE SUPERVISION OF:
Justin Smeets
JUSTIN SMEETS, PE
R.C.E. NO. 78314, EXP 09/30/23
DATE 8/31/2023

APPROVED BY:
SAM SAMPAT, P.E.
SENIOR CIVIL ENGINEER
DATE _____

ENGINEERING DIVISION

WATER MAIN REPLACEMENT
247TH STREET AREA

TRAFFIC CONTROL PLAN
WESTERN AVENUE WORK AREA

PROJECT AND SHEET TITLE

DESIGNED BY: R. DENNIS
DRAWN BY: R. DENNIS
CHECKED BY: J. SMEETS
PROJECT NO. 2021-1-WA
SHT 12 OF 21 SHTS

Sep 05, 2023 - 2:44pm - C:\Users\JustinSmeets\Box\Projects\Design\247th Street Area Water Main Replacement\Project\Design\CAD\Plan\22 Traffic Control - Western Avenue

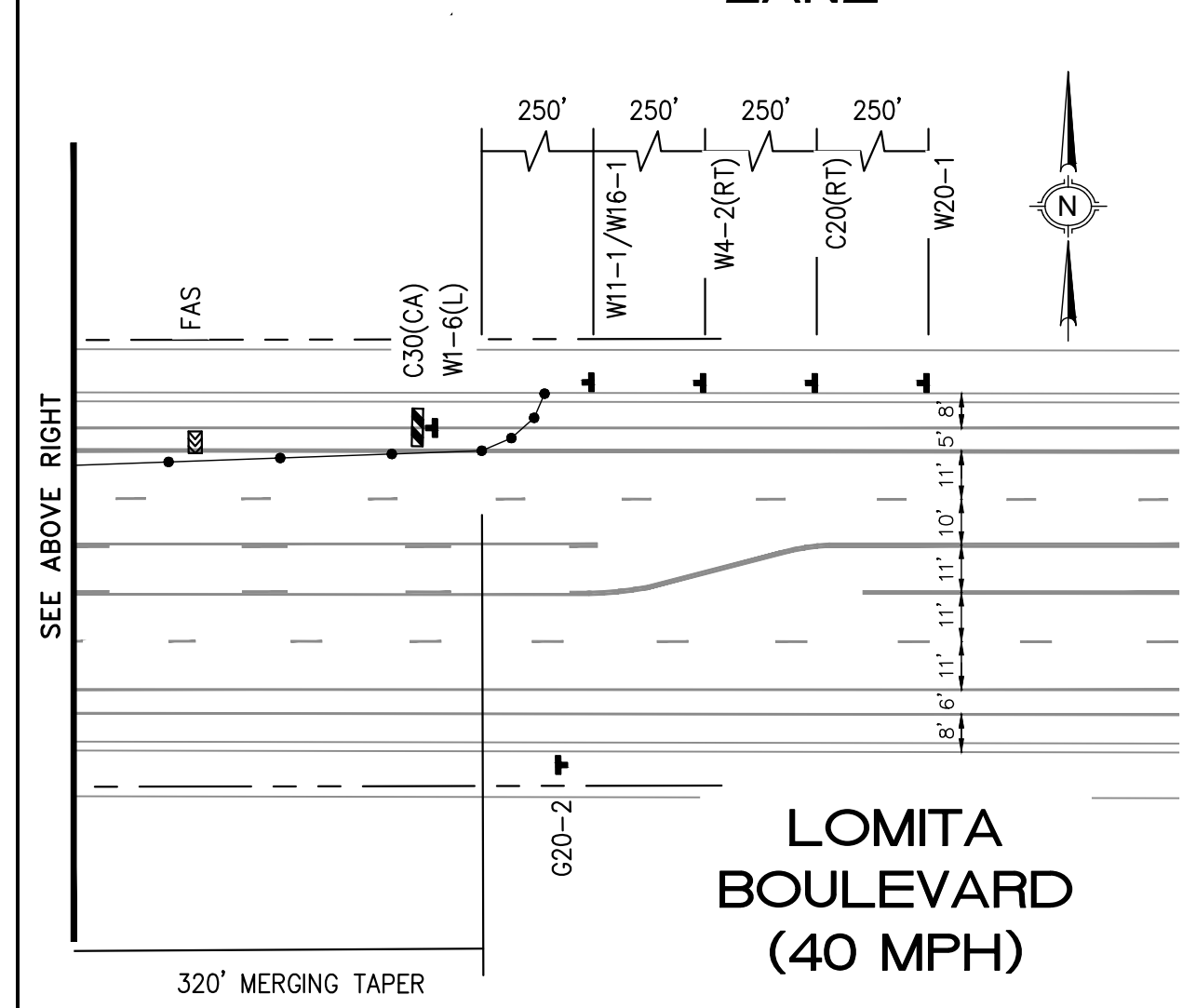
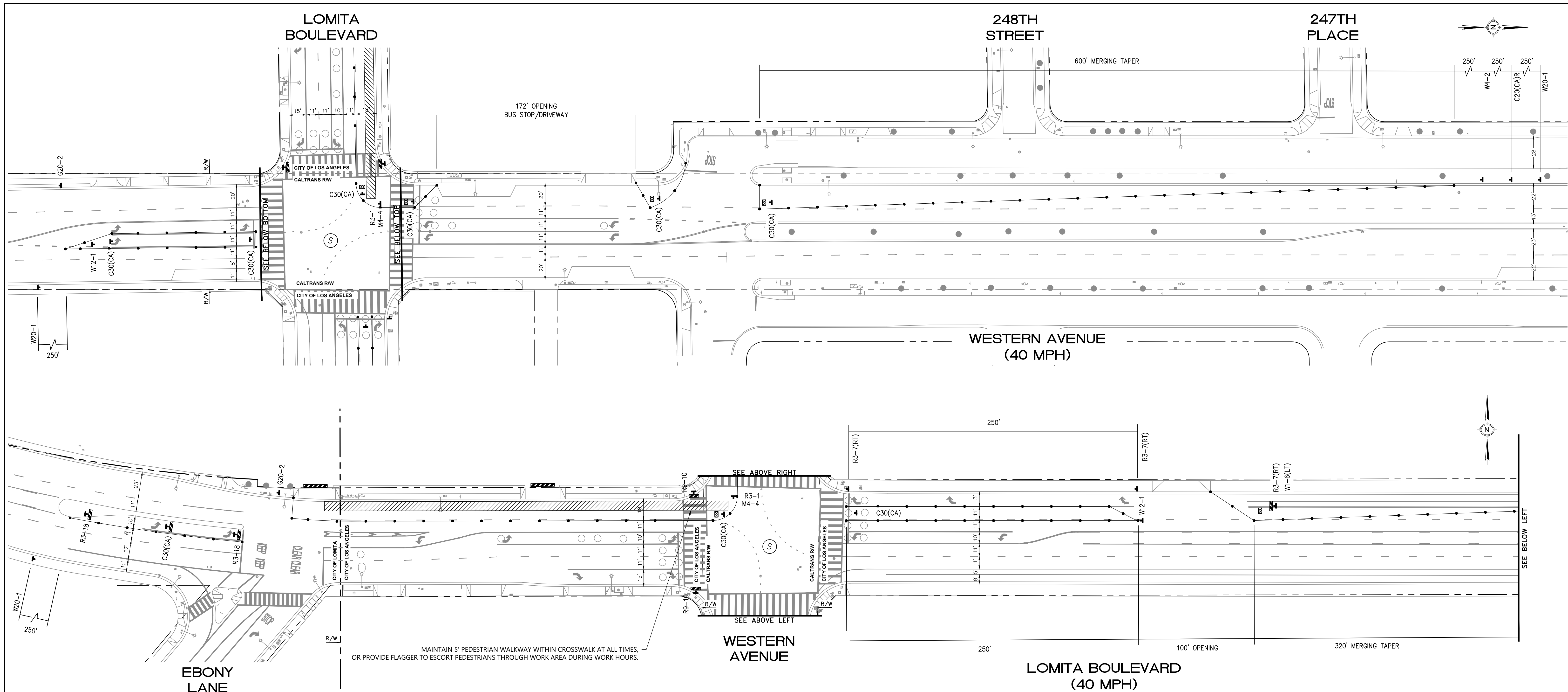

MAINTAIN 5' PEDESTRIAN WALKWAY WITHIN CROSSWALK AT ALL TIMES OR PROVIDE FLAGGER TO ESCORT PEDESTRIANS THROUGH WORK AREA DURING WORK HOURS.

LEGEND:

- PORTABLE DELINEATOR (28" MIN.)
- W20-1+ TEMPORARY CONSTRUCTION SIGN (OF TYPE INDICATED)
- ▨ TYPE II BARRICADE WITH SIGN MOUNTED ON BARRICADE (IF SHOWN)
- ▨ CONSTRUCTION AREA
- ◀▶ FLASHING ARROW SIGN
- (S) SIGNALIZED INTERSECTION
- FLAGGER

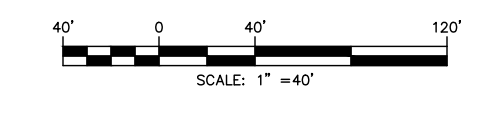
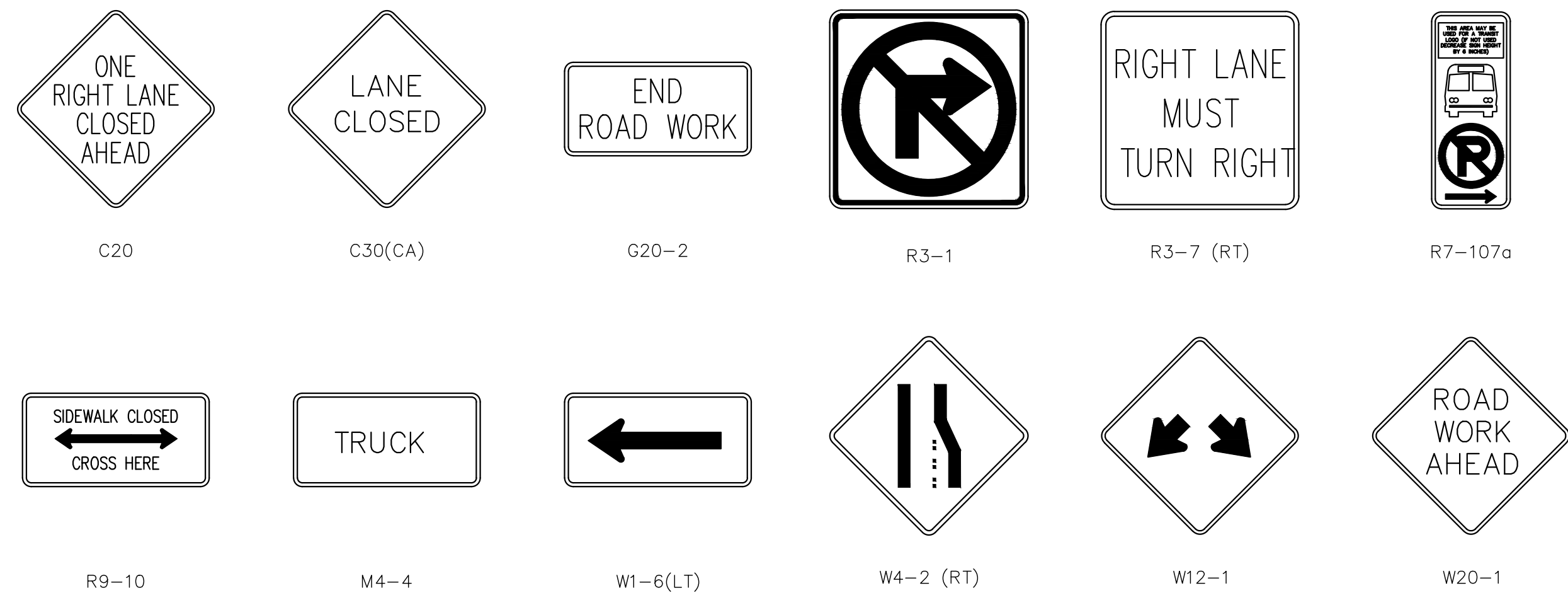

NO WORK SHALL BE DONE ON THIS SITE UNTIL BELOW AGENCY IS NOTIFIED OF INTENTION TO GRADE OR EXCAVATE.

811
Know what's below.
Call before you dig.
TWO WORKING DAYS BEFORE YOU DIG

ONWARD ENGINEERING
300 S. HARBOR BLVD., SUITE 814
ANAHEIM, CA. 92805
P: (714) 533-3050
F: (714) 808-1270
ONWARDENGINEERING.COM

NO.	DATE	BY	DESCRIPTION	APPROVED
R E V I S I O N S				



PREPARED UNDER THE SUPERVISION OF:
Justin Smeets
JUSTIN SMEETS, PE
R.C.E. NO. 78314, EXP 09/30/23
DATE 8/31/2023

APPROVED BY:
SAM SAMPAT, P.E.
SENIOR CIVIL ENGINEER
DATE _____
ENGINEERING DIVISION

WATER MAIN REPLACEMENT
247TH STREET AREA

TRAFFIC CONTROL PLAN
LOMITA BOULEVARD WORK AREA

PROJECT AND SHEET TITLE

DESIGNED BY : R. DENNIS
DRAWN BY : R. DENNIS
CHECKED BY : J. SMEETS
PROJECT NO. 2021-1-WA
SHT 13 OF 21 SHTS

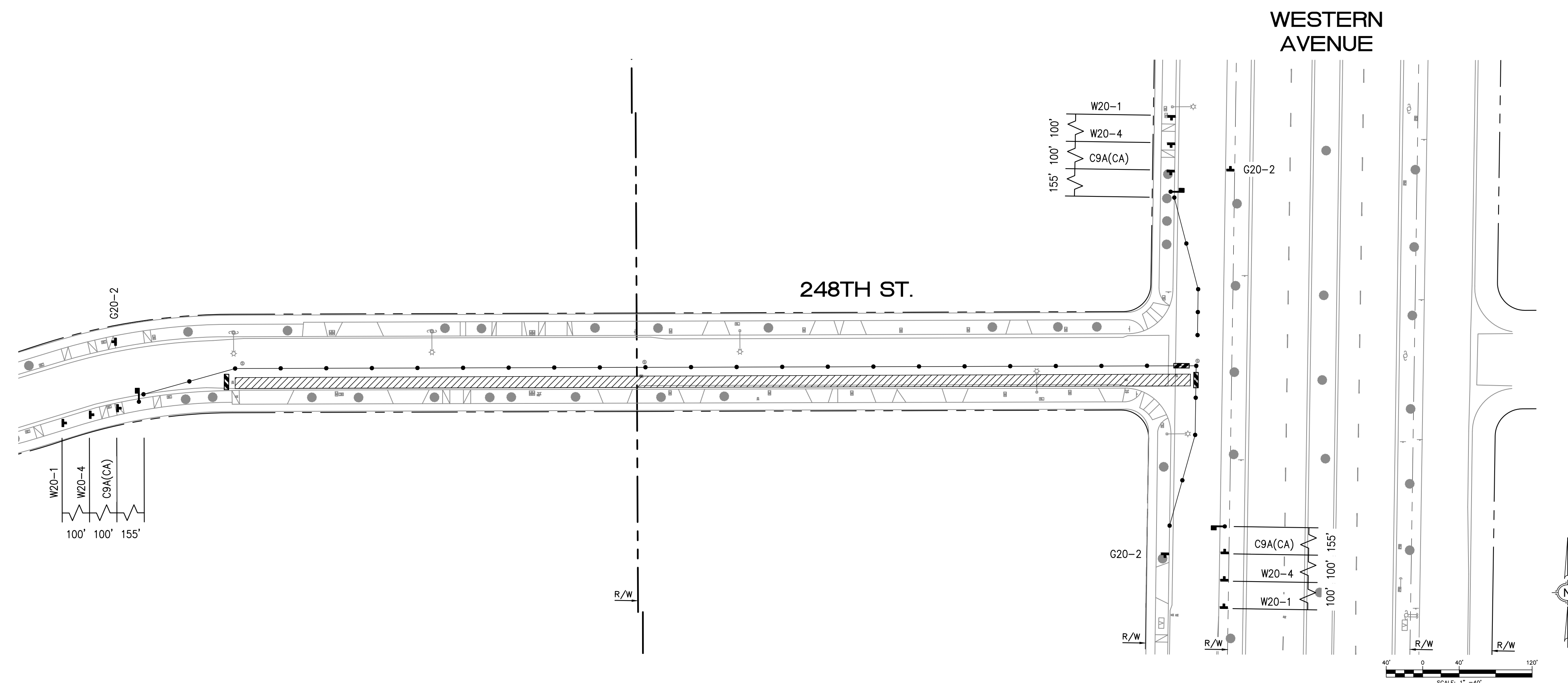

LEGEND:

- PORTABLE DELINEATOR (28" MIN.)
- W20-1+ TEMPORARY CONSTRUCTION SIGN (OF TYPE INDICATED)
- ▨ TYPE II BARRICADE WITH SIGN MOUNTED ON BARRICADE (IF SHOWN)
- ▨ CONSTRUCTION AREA
- ◀▶ FLASHING ARROW SIGN
- FLAGGER



C9A(CA)

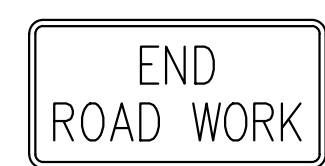

G20-2



W20-1



W20-4

NO WORK SHALL BE DONE ON THIS SITE UNTIL BELOW AGENCY IS NOTIFIED OF INTENTION TO GRADE OR EXCAVATE.

811
Know what's below.
Call before you dig.
TWO WORKING DAYS BEFORE YOU DIG

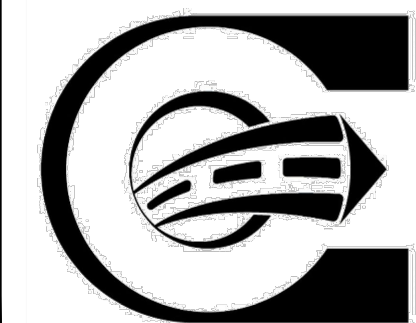

ONWARD ENGINEERING
300 S. HARBOR BLVD., SUITE 814
ANAHEIM, CA. 92805
P: (714) 533-3050
F: (714) 808-1270
ONWARDENGINEERING.COM

NO.	DATE	BY	DESCRIPTION	APPROVED
R E V I S I O N S				



PREPARED UNDER THE SUPERVISION OF:
Justin L. Smeets
JUSTIN SMEETS, PE
R.C.E. NO. 78314, EXP 09/30/23
DATE 8/31/2023

APPROVED BY:
SAM SAMPAT, P.E.
SENIOR CIVIL ENGINEER
DATE _____

ENGINEERING DIVISION

WATER MAIN REPLACEMENT
247TH STREET AREA

TRAFFIC CONTROL PLAN
248TH STREET WORK AREA

PROJECT AND SHEET TITLE

DESIGNED BY : R. DENNIS
DRAWN BY : R. DENNIS
CHECKED BY : J. SMEETS
PROJECT NO. 2021-1-WA
SHT 14 OF 21 SHTS

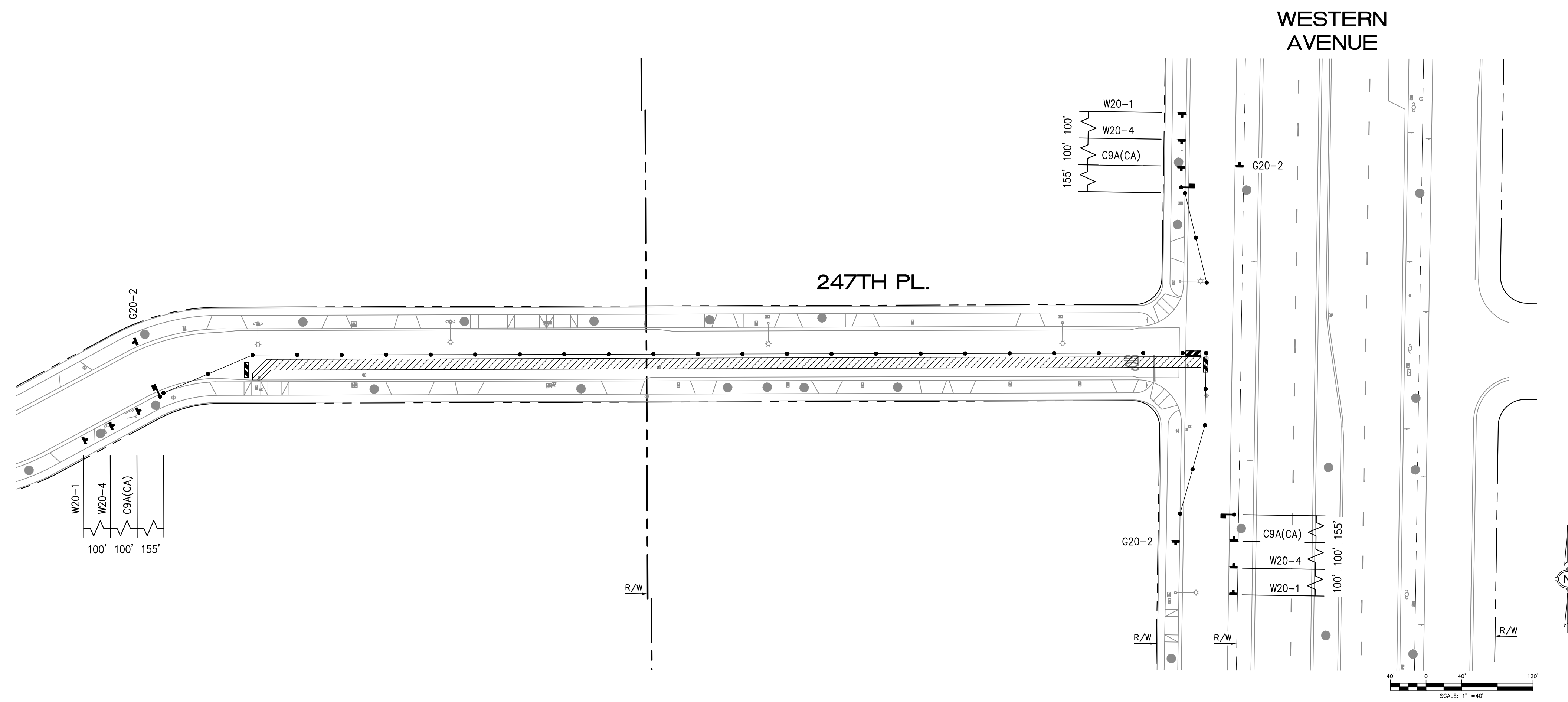

LEGEND:

- PORTABLE DELINEATOR (28" MIN.)
- W20-1+ TEMPORARY CONSTRUCTION SIGN (OF TYPE INDICATED)
- ▨ TYPE II BARRICADE WITH SIGN MOUNTED ON BARRICADE (IF SHOWN)
- ▨ CONSTRUCTION AREA
- ◀▶ FLASHING ARROW SIGN
- 👤 FLAGGER



C9A(CA)

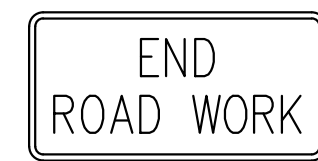

G20-2



W20-1



W20-4

NO WORK SHALL BE DONE ON THIS SITE UNTIL BELOW AGENCY IS NOTIFIED OF INTENTION TO GRADE OR EXCAVATE.

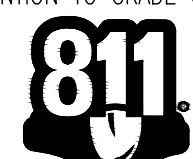

Know what's below. Call before you dig.

TWO WORKING DAYS BEFORE YOU DIG

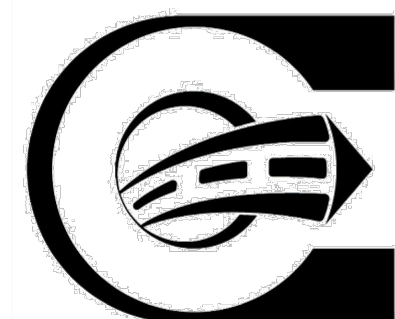

ONWARD ENGINEERING

300 S. HARBOR BLVD., SUITE 814
ANAHEIM, CA. 92805
P: (714) 533-3050
F: (714) 808-1270
ONWARDENGINEERING.COM

NO.	DATE	BY	DESCRIPTION	APPROVED
R E V I S I O N S				



PREPARED UNDER THE SUPERVISION OF:

Justin Smeets
JUSTIN SMEETS, PE
R.C.E. NO. 78314, EXP 09/30/23

8/31/2023
DATE

APPROVED BY:

SAM SAMPAT, P.E.
SENIOR CIVIL ENGINEER

DATE

ENGINEERING DIVISION

WATER MAIN REPLACEMENT

247TH STREET AREA

TRAFFIC CONTROL PLAN
247TH PLACE WORK AREA

PROJECT AND SHEET TITLE

DESIGNED BY:

R. DENNIS

DRAWN BY:

R. DENNIS

CHECKED BY:

J. SMEETS

PROJECT NO.

2021-1-WA

SHT 15 OF 21 SHTS

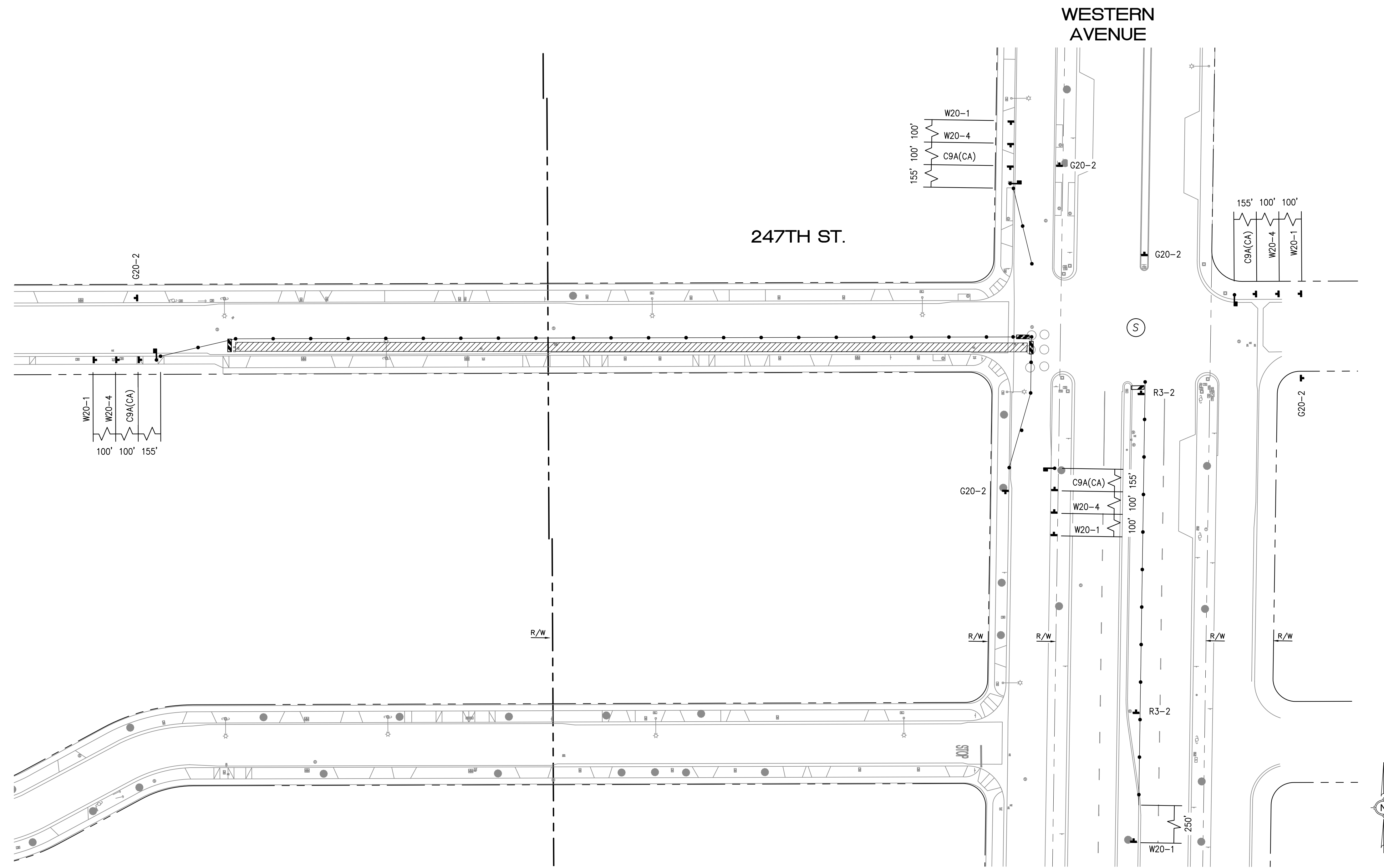

LEGEND:

- PORTABLE DELINEATOR (28" MIN.)
- W20-1 + TEMPORARY CONSTRUCTION SIGN (OF TYPE INDICATED)
- ▨ TYPE II BARRICADE WITH SIGN MOUNTED ON BARRICADE (IF SHOWN)
- ▨ CONSTRUCTION AREA
- ▨ FLASHING ARROW SIGN
- Ⓢ SIGNALIZED INTERSECTION
- FLAGGER



C9A(CA)

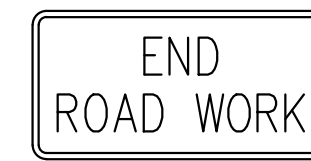

G20-2

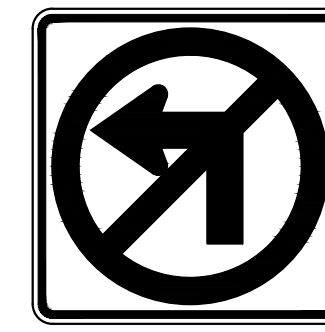

R3-2



W20-1



W20-4

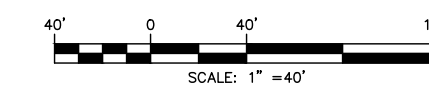

NO WORK SHALL BE DONE ON THIS SITE UNTIL BELOW AGENCY IS NOTIFIED OF INTENTION TO GRADE OR EXCAVATE.

811
Know what's below.
Call before you dig.
TWO WORKING DAYS BEFORE YOU DIG

ONWARD ENGINEERING
300 S. HARBOR BLVD., SUITE 814
ANAHEIM, CA. 92805
P: (714) 533-3050
F: (714) 808-1270
ONWARDENGINEERING.COM

NO.	DATE	BY	DESCRIPTION	APPROVED
R E V I S I O N S				



PREPARED UNDER THE SUPERVISION OF:
Justin Smeets
JUSTIN SMEETS, PE
R.C.E. NO. 78314, EXP 09/30/23
DATE: 8/31/2023

APPROVED BY:
SAM SAMPAT, P.E.
SENIOR CIVIL ENGINEER
DATE: _____
ENGINEERING DIVISION

WATER MAIN REPLACEMENT
247TH STREET AREA
TRAFFIC CONTROL PLAN
247TH STREET
PROJECT AND SHEET TITLE

DESIGNED BY: R. DENNIS
DRAWN BY: R. DENNIS
CHECKED BY: J. SMEETS
PROJECT NO. 2021-1-WA
SHT 16 OF 21 SHTS

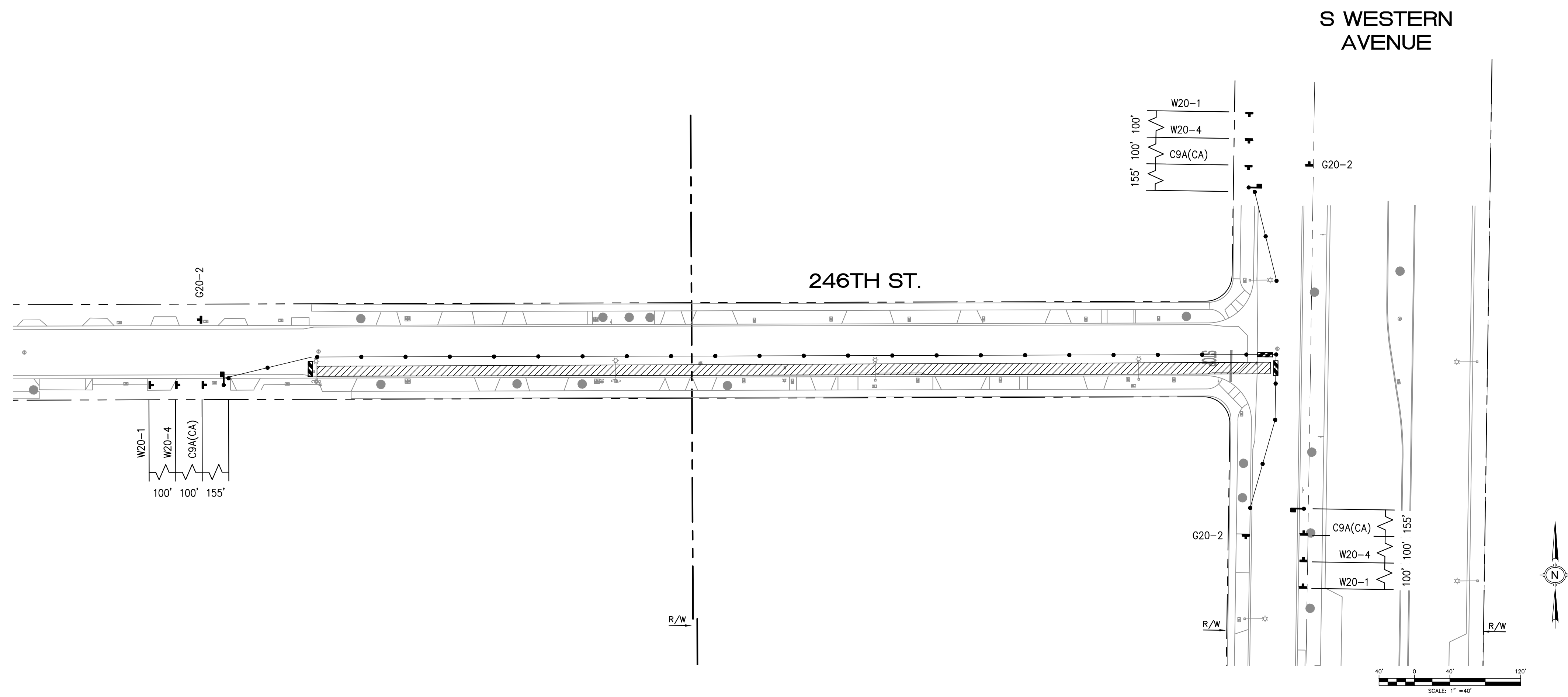

LEGEND:

- PORTABLE DELINEATOR (28" MIN.)
- W20-1+ TEMPORARY CONSTRUCTION SIGN (OF TYPE INDICATED)
- ▨ TYPE II BARRICADE WITH SIGN MOUNTED ON BARRICADE (IF SHOWN)
- ▨ CONSTRUCTION AREA
- ◀▶ FLASHING ARROW SIGN
- 👤 FLAGGER



C9A(CA)

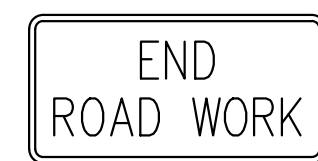

G20-2



R3-2



W20-1



W20-4

NO WORK SHALL BE DONE ON THIS SITE UNTIL BELOW AGENCY IS NOTIFIED OF INTENTION TO GRADE OR EXCAVATE.

811
Know what's below.
Call before you dig.
TWO WORKING DAYS BEFORE YOU DIG

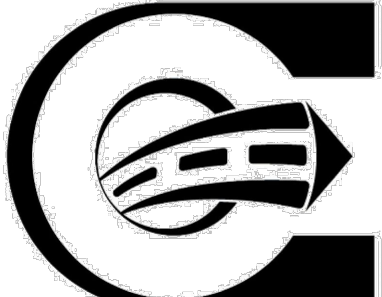

ONWARD ENGINEERING
300 S. HARBOR BLVD., SUITE 814
ANAHEIM, CA. 92805
P: (714) 533-3050
F: (714) 808-1270
ONWARDENGINEERING.COM

NO.	DATE	BY	DESCRIPTION	APPROVED
R E V I S I O N S				



PREPARED UNDER THE SUPERVISION OF:
Justin L. Smeets
JUSTIN SMEETS, PE
R.C.E. NO. 78314, EXP 09/30/23
DATE 8/31/2023

APPROVED BY:
SAM SAMPAT, P.E.
SENIOR CIVIL ENGINEER
DATE _____

ENGINEERING DIVISION

WATER MAIN REPLACEMENT
247TH STREET AREA

TRAFFIC CONTROL PLAN
246TH STREET WORK AREA

PROJECT AND SHEET TITLE

DESIGNED BY : R. DENNIS
DRAWN BY : R. DENNIS
CHECKED BY : J. SMEETS
PROJECT NO. 2021-1-WA
SHT 17 OF 21 SHTS

Sep 05, 2023 - 2:40pm - C:\Users\JustinSmeets\Box\Projects\Design\Units-247th Street Area Water Main Replacement Project\Design\CAD\Plans\17 Traffic Control - 246th St.dwg

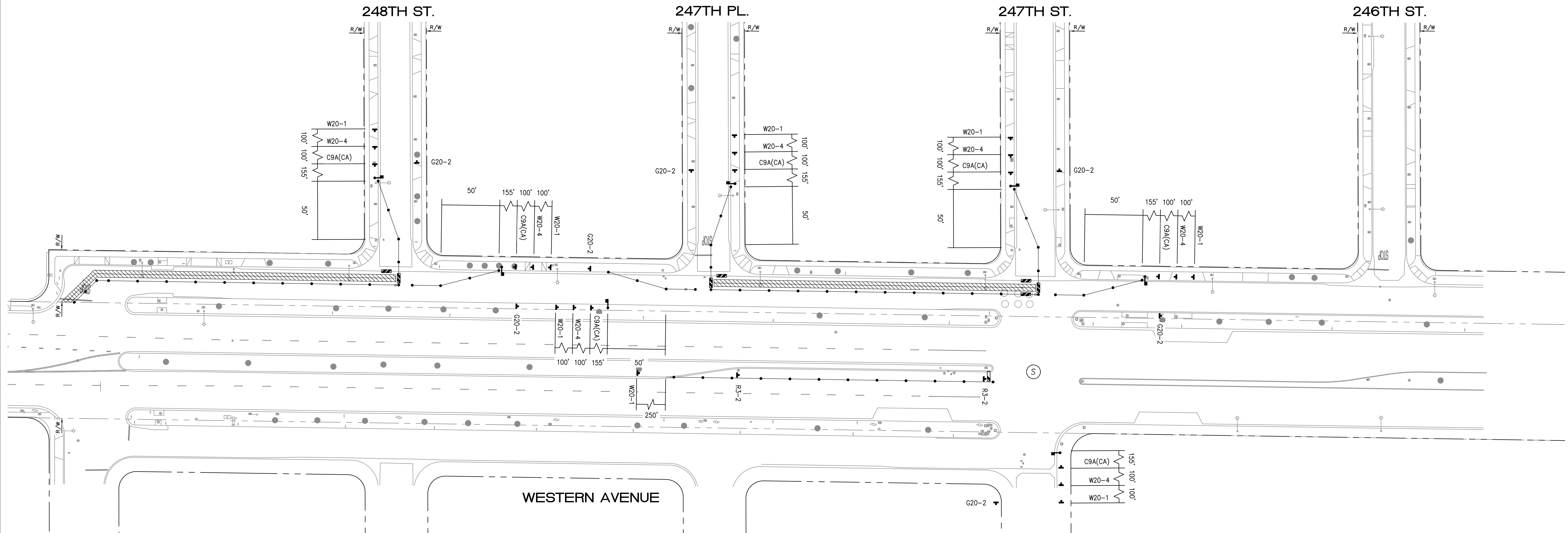

LEGEND:

- PORTABLE DELINEATOR (28" MIN.)
- W20-1+ TEMPORARY CONSTRUCTION SIGN (OF TYPE INDICATED)
- ▨ TYPE II BARRICADE WITH SIGN MOUNTED ON BARRICADE (IF SHOWN)
- ▨ CONSTRUCTION AREA
- ◀▶ FLASHING ARROW SIGN
- Ⓢ SIGNALIZED INTERSECTION
- ⌚ FLAGGER

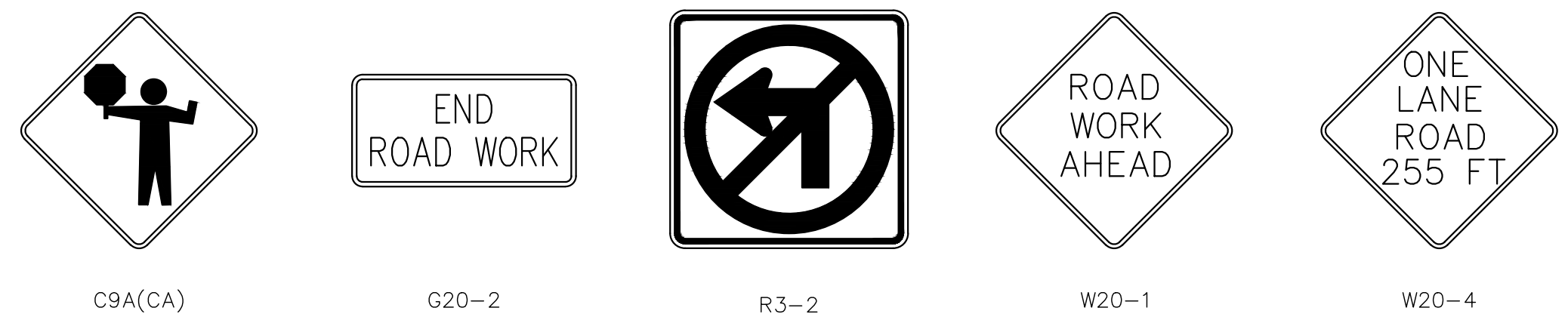

NO WORK SHALL BE DONE ON THIS SITE UNTIL BELOW AGENCY IS NOTIFIED OF INTENTION TO GRADE OR EXCAVATE.

811
Know what's below.
Call before you dig.
TWO WORKING DAYS BEFORE YOU DIG

ONWARD ENGINEERING
300 S. HARBOR BLVD., SUITE 814
ANAHEIM, CA. 92805
P: (714) 533-3050
F: (714) 808-1270
ONWARDENGINEERING.COM

NO.	DATE	BY	DESCRIPTION	APPROVED
R E V I S I O N S				



PREPARED UNDER THE SUPERVISION OF:
Justin Smeets
JUSTIN SMEETS, P.E.
R.C.E. NO. 78314, EXP 09/30/23
DATE 8/31/2023

APPROVED BY:
SAM SAMPAT, P.E.
SENIOR CIVIL ENGINEER
DATE _____

ENGINEERING DIVISION

WATER MAIN REPLACEMENT
247TH STREET AREA

TRAFFIC CONTROL PLAN
WESTERN AVENUE FRONTAGE ROAD WORK AREAS 1 AND 3

PROJECT AND SHEET TITLE

DESIGNED BY: R. DENNIS
DRAWN BY: R. DENNIS
CHECKED BY: J. SMEETS
PROJECT NO. 2021-1-WA
SHT 18 OF 21 SHTS

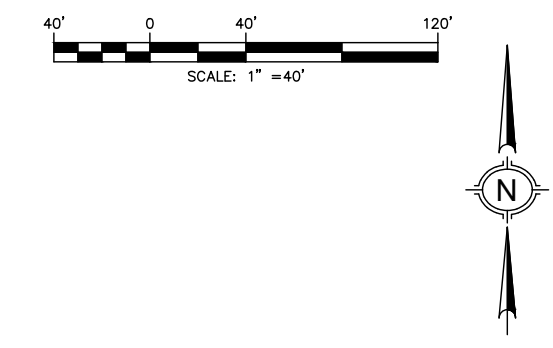
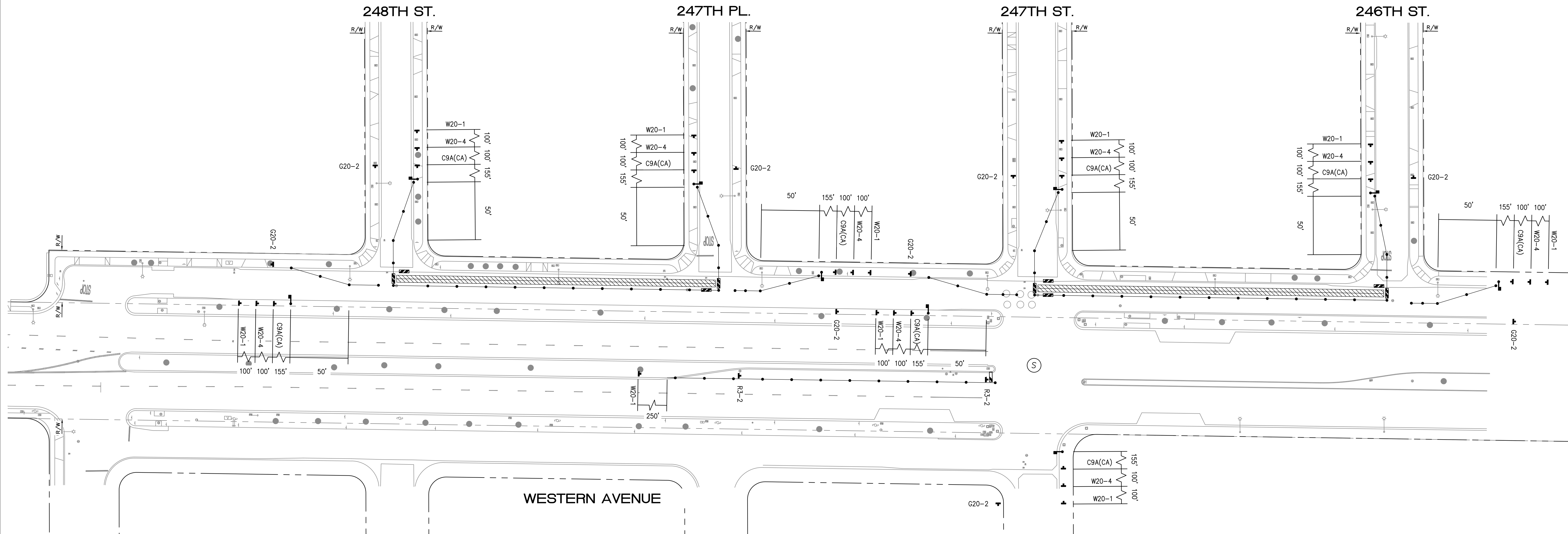

LEGEND:

- PORTABLE DELINEATOR (28" MIN.)
- W20-1+ TEMPORARY CONSTRUCTION SIGN (OF TYPE INDICATED)
- ▨ TYPE II BARRICADE WITH SIGN MOUNTED ON BARRICADE (IF SHOWN)
- ▨ CONSTRUCTION AREA
- ◀▶ FLASHING ARROW SIGN
- Ⓢ SIGNALIZED INTERSECTION
- ⚓ FLAGGER



NO WORK SHALL BE DONE ON THIS SITE UNTIL BELOW AGENCY IS NOTIFIED OF INTENTION TO GRADE OR EXCAVATE.

811
Know what's below.
Call before you dig.
TWO WORKING DAYS BEFORE YOU DIG

ONWARD ENGINEERING
300 S. HARBOR BLVD., SUITE 814
ANAHEIM, CA. 92805
P: (714) 533-3050
F: (714) 808-1270
ONWARDENGINEERING.COM

NO.	DATE	BY	DESCRIPTION	APPROVED
R E V I S I O N S				



PREPARED UNDER THE SUPERVISION OF:
Justin Smeets
JUSTIN SMEETS, PE
R.C.E. NO. 78314, EXP 09/30/23
DATE 8/31/2023

APPROVED BY: _____ DATE _____
SAM SAMPAT, P.E.
SENIOR CIVIL ENGINEER
ENGINEERING DIVISION

WATER MAIN REPLACEMENT
247TH STREET AREA

TRAFFIC CONTROL PLAN
WESTERN AVENUE FRONTAGE ROAD WORK AREAS 2 AND 4



PROJECT AND SHEET TITLE

DESIGNED BY: R. DENNIS
DRAWN BY: R. DENNIS
CHECKED BY: J. SMEETS
PROJECT NO. 2021-1-WA
SHT 19 OF 21 SHTS



GENERAL NOTES - TRAFFIC DETOURS

1. ALL CONSTRUCTION AREA AND DETOUR SIGNING SHALL CONFORM TO THE LATEST CALIFORNIA MANUAL ON UNIFORM TRAFFIC CONTROL DEVICES (CA MUTCD), AS A MINIMUM STANDARD. THE CONTRACTOR MAY EXCEED THIS STANDARD IF TRAFFIC CONDITIONS WARRANT OR AS REQUESTED BY THE ENGINEER.
2. SEE TABLE 6C-1 FOR SUGGESTED ADVANCE WARNING SIGN SPACING FOR URBAN (HIGH SPEED) CATEGORY.
3. AT THE END OF EACH FULL CLOSURE PERIOD ALL LANES WILL BE OPENED TO VEHICULAR, BICYCLE, AND PEDESTRIAN TRAFFIC IN ACCORDANCE WITH THE TRAFFIC CONTROL PLAN. ALL CONFLICTING TEMPORARY TRAFFIC CONTROLS WILL BE REMOVED OR COVERED. CONFLICTING TEMPORARY STRIPING WILL BE REMOVED IN ACCORDANCE WITH THE SPECIAL PROVISIONS.
4. TEMPORARY TRAFFIC CONTROLS FOR EACH PHASE SHALL BE INSTALLED ONLY WHERE CONSTRUCTION WILL OCCUR DURING A SINGLE CLOSURE AND BE REMOVED AT THE END OF EACH CONSTRUCTION PERIOD.
5. CONFLICTING PERMANENT SIGNING SHALL BE COVERED AT SUCH TIME THAT THE DETOUR IS OPERATIONAL.
6. DETOUR PLANS ARE APPLICABLE ONLY FOR THE CITY OF LOMITA, 247TH STREET AREA WATER MAIN IMPROVEMENT PLANS AND SHALL CONFORM TO THE PLANS AND NOTES PROVIDED.

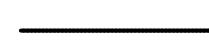
LEGEND:

-  TEMPORARY CONSTRUCTION SIGN
-  INTENDED TRAFFIC MOVEMENT
-  CLOSURE AREA
-  DETOUR ROUTE

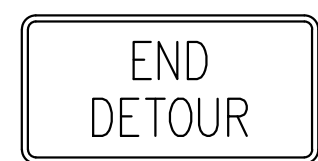
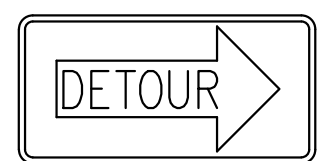
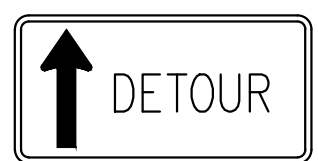
SIGN LEGEND:

-  END DETOUR
M4-8A
-  DETOUR
M4-10
-  DETOUR
SC3(CA)
-  247TH STREET
SN1

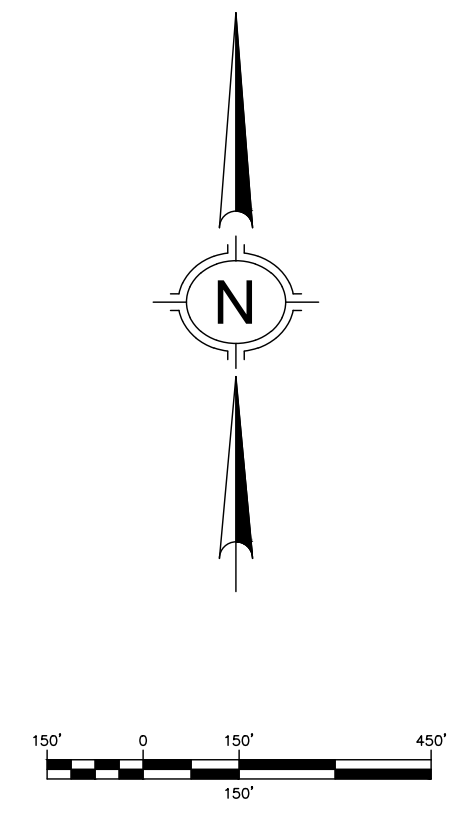
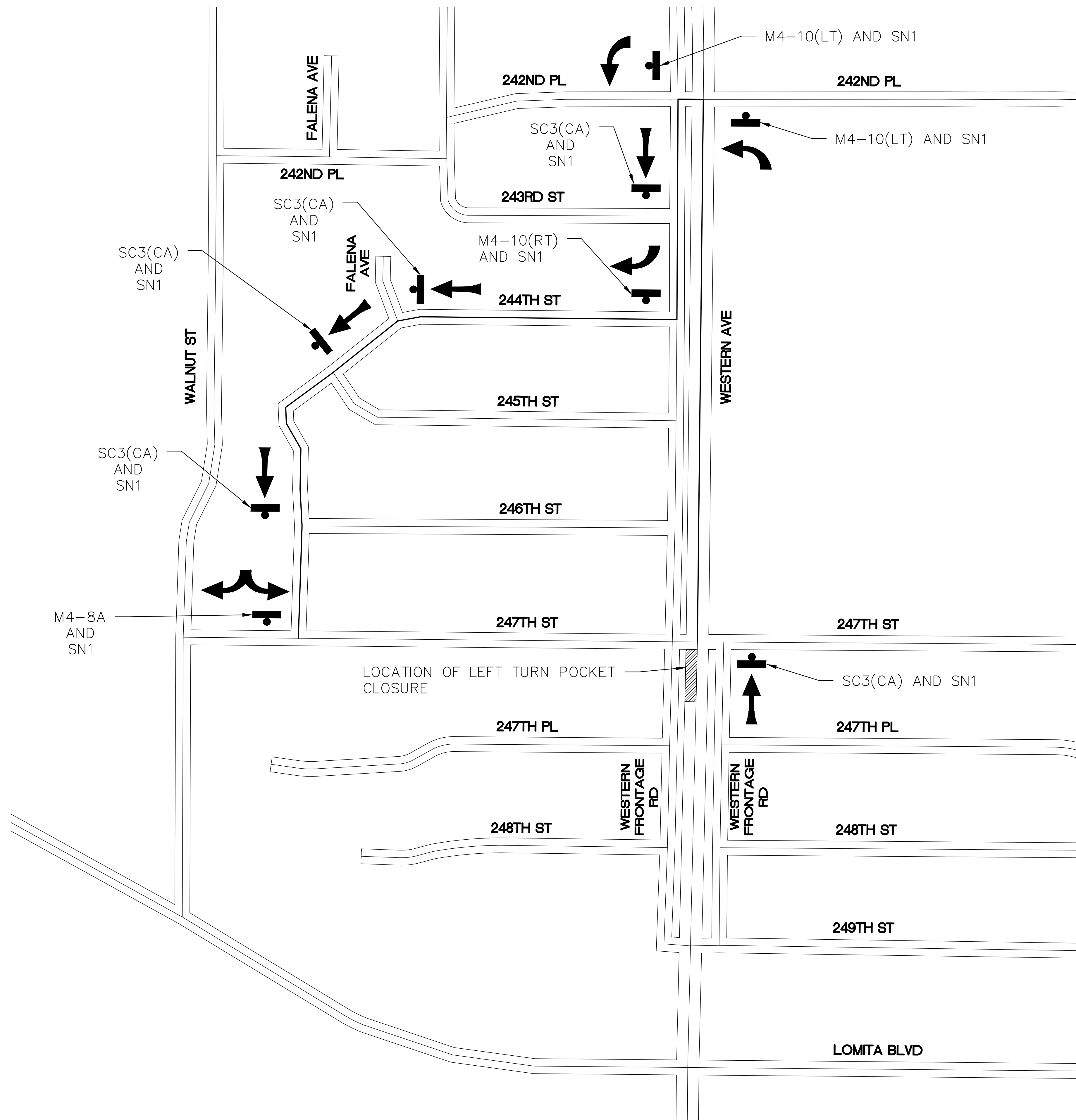

NO WORK SHALL BE DONE ON THIS SITE UNTIL BELOW AGENCY IS NOTIFIED OF INTENTION TO GRADE OR EXCAVATE.

811
Know what's below.
Call before you dig.
TWO WORKING DAYS BEFORE YOU DIG

ONWARD ENGINEERING
300 S. HARBOR BLVD., SUITE 814
ANAHEIM, CA. 92805
P: (714) 533-3050
F: (714) 808-1270
ONWARDENGINEERING.COM

NO.	DATE	BY	DESCRIPTION	APPROVED
R E V I S I O N S				



PREPARED UNDER THE SUPERVISION OF:
Justin L. Smeets
JUSTIN-SMEETS, P.E.
R.C.E. NO. 78314, EXP 09/30/23
DATE 8/31/2023

APPROVED BY:
SAM SAMPAT, P.E.
SENIOR CIVIL ENGINEER
DATE _____
ENGINEERING DIVISION

WATER MAIN REPLACEMENT
247TH STREET AREA
WESTERN AVENUE AND 247TH STREET
DETOUR PLAN

PROJECT AND SHEET TITLE

DESIGNED BY : R. DENNIS
DRAWN BY : R. DENNIS
CHECKED BY : J. SMEETS
PROJECT NO. 2021-1-WA
SHT 20 OF 21 SHTS

CALTRANS PERMIT NO. 722-NUS-2211
Sep 05, 2023 - 2:46pm - C:\Users\JustinSmeets\Box\Projects\Design\2021-1-WA\247th Street Area Water Main Replacement Project\Design\CAD\Plan\20 Detour Plan.dwg

MATCH LINE - SEE BELOW RIGHT

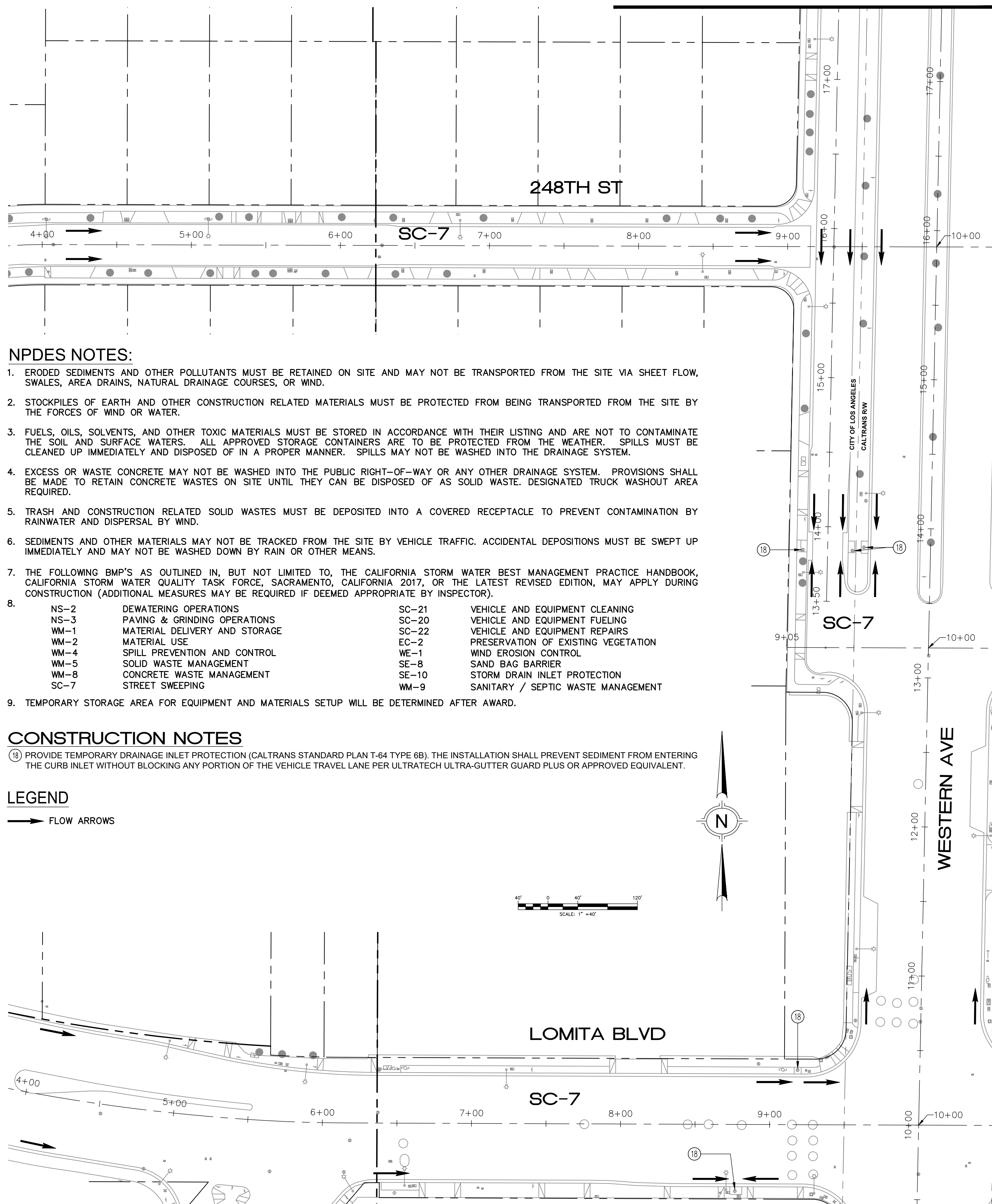

NPDES NOTES:

1. ERODED SEDIMENTS AND OTHER POLLUTANTS MUST BE RETAINED ON SITE AND MAY NOT BE TRANSPORTED FROM THE SITE VIA SHEET FLOW, SWALES, AREA DRAINS, NATURAL DRAINAGE COURSES, OR WIND.
2. STOCKPILES OF EARTH AND OTHER CONSTRUCTION RELATED MATERIALS MUST BE PROTECTED FROM BEING TRANSPORTED FROM THE SITE BY THE FORCES OF WIND OR WATER.
3. FUELS, OILS, SOLVENTS, AND OTHER TOXIC MATERIALS MUST BE STORED IN ACCORDANCE WITH THEIR LISTING AND ARE NOT TO CONTAMINATE THE SOIL AND SURFACE WATERS. ALL APPROVED STORAGE CONTAINERS ARE TO BE PROTECTED FROM THE WEATHER. SPILLS MUST BE CLEANED UP IMMEDIATELY AND DISPOSED OF IN A PROPER MANNER. SPILLS MAY NOT BE WASHED INTO THE DRAINAGE SYSTEM.
4. EXCESS OR WASTE CONCRETE MAY NOT BE WASHED INTO THE PUBLIC RIGHT-OF-WAY OR ANY OTHER DRAINAGE SYSTEM. PROVISIONS SHALL BE MADE TO RETAIN CONCRETE WASTES ON SITE UNTIL THEY CAN BE DISPOSED OF AS SOLID WASTE. DESIGNATED TRUCK WASHOUT AREA REQUIRED.
5. TRASH AND CONSTRUCTION RELATED SOLID WASTES MUST BE DEPOSITED INTO A COVERED RECEPTACLE TO PREVENT CONTAMINATION BY RAINWATER AND DISPERSAL BY WIND.
6. SEDIMENTS AND OTHER MATERIALS MAY NOT BE TRACKED FROM THE SITE BY VEHICLE TRAFFIC. ACCIDENTAL DEPOSITIONS MUST BE SWEEPED UP IMMEDIATELY AND MAY NOT BE WASHED DOWN BY RAIN OR OTHER MEANS.
7. THE FOLLOWING BMP'S AS OUTLINED IN, BUT NOT LIMITED TO, THE CALIFORNIA STORM WATER BEST MANAGEMENT PRACTICE HANDBOOK, CALIFORNIA STORM WATER QUALITY TASK FORCE, SACRAMENTO, CALIFORNIA 2017, OR THE LATEST REVISED EDITION, MAY APPLY DURING CONSTRUCTION (ADDITIONAL MEASURES MAY BE REQUIRED IF DEEMED APPROPRIATE BY INSPECTOR).
8.

NS-2	DEWATERING OPERATIONS	SC-21	VEHICLE AND EQUIPMENT CLEANING
NS-3	PAVING & GRINDING OPERATIONS	SC-20	VEHICLE AND EQUIPMENT FUELING
WM-1	MATERIAL DELIVERY AND STORAGE	SC-22	VEHICLE AND EQUIPMENT REPAIRS
WM-2	MATERIAL USE	EC-2	PRESERVATION OF EXISTING VEGETATION
WM-4	SPILL PREVENTION AND CONTROL	WE-1	WIND EROSION CONTROL
WM-5	SOLID WASTE MANAGEMENT	SE-8	SAND BAG BARRIER
WM-8	CONCRETE WASTE MANAGEMENT	SE-10	STORM DRAIN INLET PROTECTION
SC-7	STREET SWEEPING	WM-9	SANITARY / SEPTIC WASTE MANAGEMENT
9. TEMPORARY STORAGE AREA FOR EQUIPMENT AND MATERIALS SETUP WILL BE DETERMINED AFTER AWARD.

CONSTRUCTION NOTES

- 18 PROVIDE TEMPORARY DRAINAGE INLET PROTECTION (CALTRANS STANDARD PLAN T-64 TYPE 6B). THE INSTALLATION SHALL PREVENT SEDIMENT FROM ENTERING THE CURB INLET WITHOUT BLOCKING ANY PORTION OF THE VEHICLE TRAVEL LANE PER ULTRATECH ULTRA-GUTTER GUARD PLUS OR APPROVED EQUIVALENT.

LEGEND

→ FLOW ARROWS

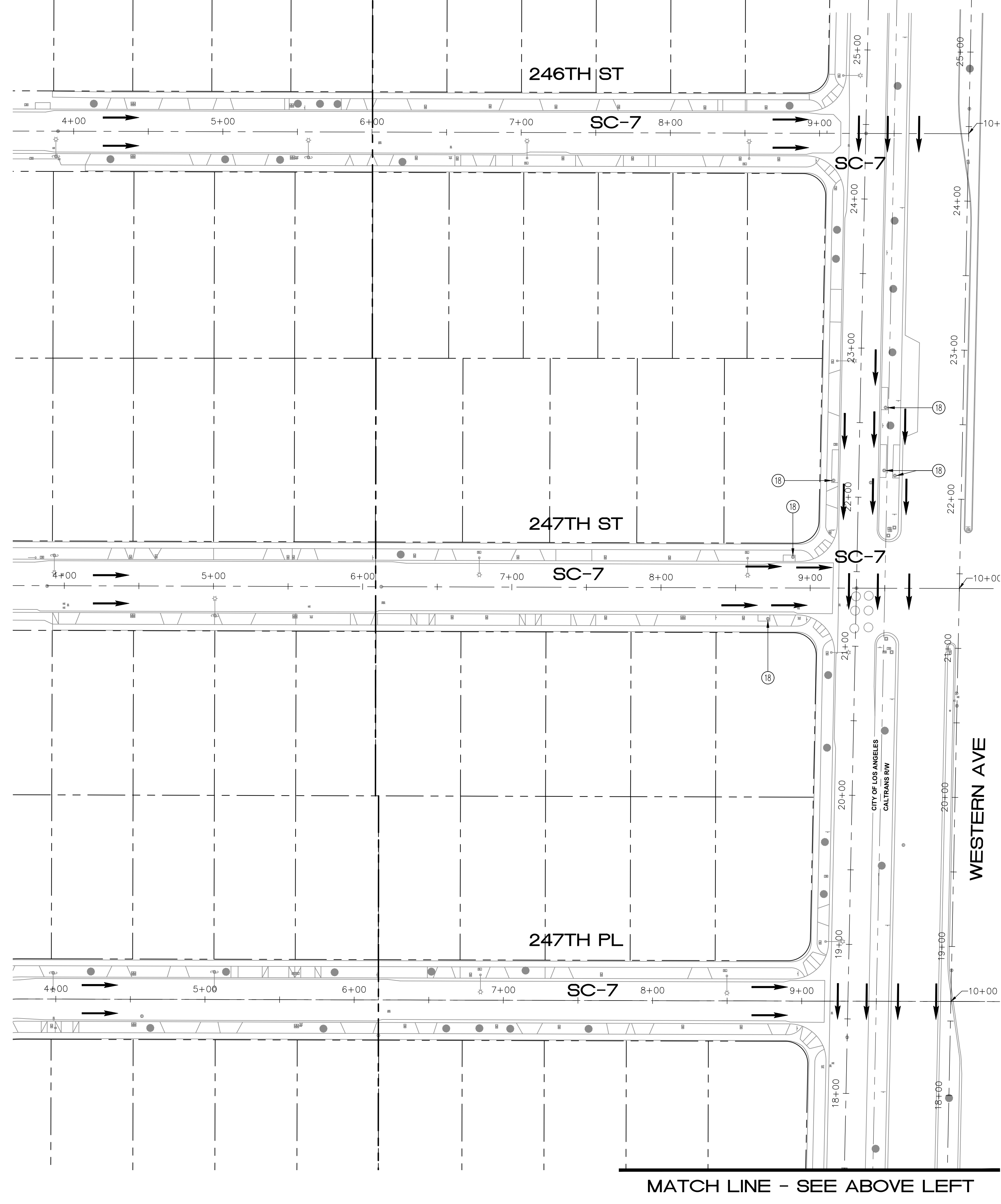
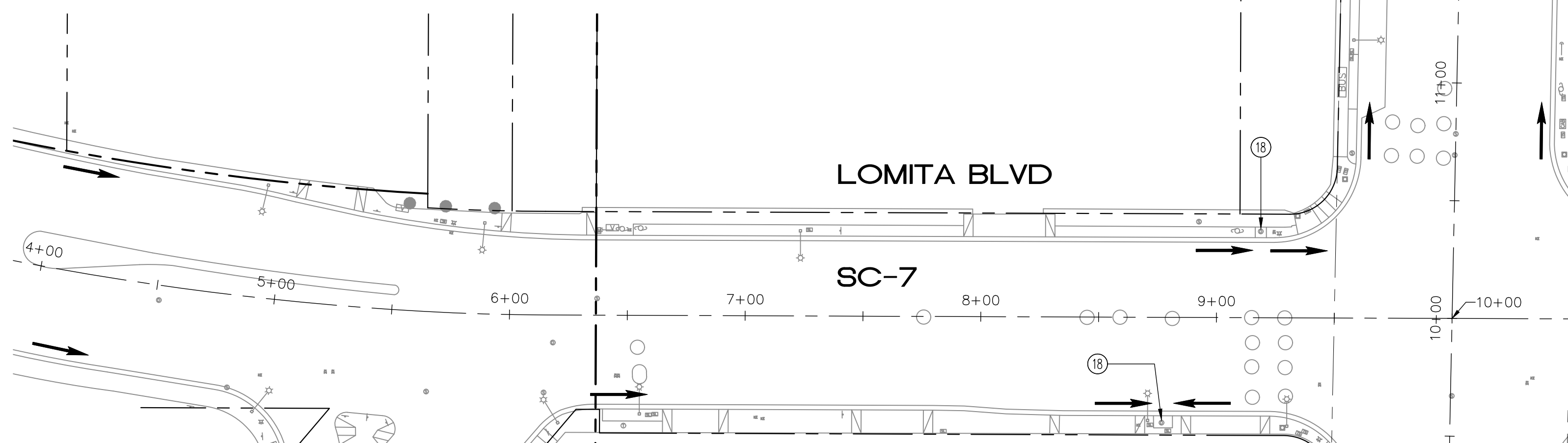

MATCH LINE - SEE ABOVE LEFT

NO WORK SHALL BE DONE ON THIS SITE UNTIL BELOW AGENCY IS NOTIFIED OF INTENTION TO GRADE OR EXCAVATE.
811
 Know what's below.
 Call before you dig.
 TWO WORKING DAYS BEFORE YOU DIG

ONWARD ENGINEERING
 300 S. HARBOR BLVD., SUITE 814
 ANAHEIM, CA. 92805
 P: (714) 533-3050
 F: (714) 808-1270
 ONWARDENGINEERING.COM

NO.	DATE	BY	DESCRIPTION	APPROVED
R E V I S I O N S				



PREPARED UNDER THE SUPERVISION OF:
Justin L. Smeets
 JUSTIN SMEETS, P.E.
 R.C.E. NO. 78314, EXP 09/30/23
 8/31/2023
 DATE

APPROVED BY:
 SAM SAMPAT, P.E.
 SENIOR CIVIL ENGINEER
 DATE _____
 ENGINEERING DIVISION

WATER MAIN REPLACEMENT
 247TH STREET AREA
EROSION CONTROL PLAN

PROJECT AND SHEET TITLE

DESIGNED BY : R. DENNIS
 DRAWN BY : R. DENNIS
 CHECKED BY : J. SMEETS
 PROJECT NO. 2021-1-WA
 SHT 21 OF 21 SHTS



CITY OF LOMITA
24300 Narbonne Avenue
Lomita, CA 90717

CONTRACT DOCUMENTS AND SPECIFICATIONS

FOR

247th STREET AREA WATER MAIN REPLACEMENT

BID OPENING
XXX XX, 2023
1:00 P.M.

Under the Supervision of:

<hr/>	
Name, Title	XX-XX-XXXX
	Date

XXXXXX 2023

TABLE OF CONTENTS

SECTION A-NOTICE INVITING BIDS (A)

NOTICE INVITING BIDS.....	A-2
---------------------------	-----

SECTION B-INSTRUCTIONS TO BIDDERS (B)

I. QUALIFICATION OF BIDDERS	B-2
II. BIDDER'S RESPONSIBILITY	B-3
III. ADDENDA TO CONTRACT DOCUMENT	B-3
IV. PREPARATION OF THE BID	B-4
V. BID BOND	B-5
VI. NON-RESPONSIVE BIDS AND REJECTION	B-5
VII. AWARD OF CONTRACT	B-5
VIII. EXECUTION OF CONTRACT	B-5
IX. APPRENTICESHIP EMPLOYMENT STANDARDS	B-6
X. PERMIT, LICENSE AND PUBLIC WORKS AGREEMENT	B-6
XI. INSURANCE	B-6
XII. PRE-BID INQUIRIES	B-6
XIII. LABOR CODE – SB 854	B-6
XIV. PREVAILING WAGE	B-6
XV. GUIDELINES DURING COVID-19 PANDEMIC.....	B-6

SECTION C-BID DOCUMENTS

BIDDERS PROPOSAL	C-2
CONTRACTOR'S AFFIDAVIT	C-7
BID BOND (10%)	C-9
LIST OF SUBCONTRACTORS	C-10
CONSTRUCTION PROJECT REFERENCES.....	C-11
VIOLATIONS OF FEDERAL, STATE OR LOCAL LAWS	C-12
DISQUALIFICATION OR DEBARMENT	C-13

SECTION D – DOCUMENTS TO BE COMPLETED AND DELIVERED TO CITY AFTER AWARD OF CONTRACT

PUBLIC WORKS AGREEMENT	D-2
CONSTRUCTION OR SERVICE CONTRACT ENDORSEMENT	D-11
PERFORMANCE BOND	D-13
LABOR AND MATERIAL BOND	D-15
WORKERS' COMPENSATION INSURANCE CERTIFICATION.....	D-18

SECTION E - SPECIAL PROVISIONS

APPENDIX I - CONSTRUCTION AND DEMOLITION DEBRIS RECYCLING SUMMARY

APPENDIX II - CITY BUSINESS LICENSE APPLICATION

APPENDIX III - CITY OF LOMITA WATER STANDARD PLANS

APPENDIX IV – CITY OF LOS ANGELES U PERMIT

APPENDIX V – CALTRANS ENCROACHMENT PERMIT

SECTION A
NOTICE INVITING BIDS



CITY OF LOMITA, CALIFORNIA

NOTICE INVITING BIDS

NOTICE IS HEREBY GIVEN that the City of Lomita, County of Los Angeles, California (hereinafter "City") will receive sealed bids at the Office of the City Clerk, City Hall, 24300 Narbonne Avenue, Lomita CA 90717 **until 1:00 PM on Day, Month XX, 2023** at which time all bids will be publicly opened and read in the City Council Chamber at the above address for:

247TH STREET AREA WATER MAIN REPLACEMENT

This project consists of water main installations on 246th St, 247th St, 247th Pl, 248th St, Western Ave, and Lomita Blvd. The existing 4-inch/6-inch water main system was constructed between 1928 and 1930 and has exceeded its useful service life. To provide improved flow, pressure and fires protection, installing approximately 3,300 linear feet of new 8-inch PVC water mains is needed. The existing water main currently runs along the property line and the new 8-inch main will be installed in the street along 246th St, 247th St, 247th Pl, 248th St, Western Avenue and Lomita Blvd. Improvements will include trenching and installation of new 8-inch PVC water main, water main fittings, valves, water services, water meters and fire hydrants.

The Contractor shall perform all work required for such construction in accordance with the Contract Documents and subject to the terms and conditions of the Contract, complete and ready for use.

Each bid must be submitted in writing on a bid proposal furnished by the City. Bids must conform and be responsive to all contract documents. All bids must be sealed and must be plainly marked in the lower left-hand corner "**247TH STREET AREA WATER MAIN REPLACEMENT**".

Plans and Specifications may be downloaded and printed from the City's website at no charge at: <https://lomitacity.com/current-bids-rfps/>

Prospective bidders who only view and/or print the Plans and Specifications from the City's website will not automatically be added to the City's Plan Holder list for this project unless they send an email to the City at PublicWorks@lomitacity.com and provide the firm's name, address, telephone and contact person with a valid email address. This will ensure that the prospective bidder is listed as a "Plan Holder" and will be informed of any addenda and all information issued subsequent to obtaining the official form of proposal.

Addenda will be posted on the City website, but it shall be the bidder's responsibility to inquire for any addenda/updates to this Notice Inviting Bid prior to submitting their bid.

Each proposal must be accompanied by a cash deposit, a certified or cashier's check, or a bidder's bond, made payable to the City of Lomita, in an amount not less than 10 percent of the total bid submitted.

The successful bidder will be required to furnish a faithful performance bond in the amount of 100 percent of the contract price, and a payment bond in the amount of 100 percent of the contract price, both in a form satisfactory to the City Attorney. The successful bidder will also be required to pay the State of California prevailing wage scale as determined by the Department of Industrial Relations, available at <http://www.dir.ca.gov/Public-Works/PublicWorks.html>.

The City reserves the right to reject any or all bids and to waive any informality or irregularity in any bid received and to be the sole judge of the merits of the respective bids received. The award, if made, will be made to the lowest responsible bidder. Plans and Specifications will be available for review at City Hall.

The contractor shall possess a valid State of California Contractors License, **Class A**. All work shall be completed within **80 working days** from the date of the Notice to Proceed (NTP).

All questions regarding this bid must be submitted in writing on or before **1:00 PM on Day, Month XX, 2023**, to the Project Manager, via email at PublicWorks@lomitacity.com.

Kathleen Horn Gregory, CMC,
City Clerk

Publish in Daily Breeze on **Date 1 and Date 2, 2023**

SECTION B
INSTRUCTIONS TO BIDDERS

INSTRUCTIONS TO BIDDERS

I. QUALIFICATION OF BIDDERS

1. Competency of Bidders

The Bidder shall be thoroughly competent and capable of satisfactorily performing the Work covered by the Bid. As specified in the Bid Documents, the Bidder shall furnish statements of previous experience on similar work. When requested, the Bidder shall also furnish the plan of procedure proposed; the organization, machinery, plant and other equipment available for the Work; evidence of its financial condition and resources; and any other such documentation as may be required by the City to determine if the Bidder is responsible.

2. Contractor's License

At the time of submitting the Bid, the Bidder shall be licensed as a contractor in accordance with the provisions of Chapter 9, Division 3, of the California Business and Professions Code. **The required prime contractor license for this project is a Class A Contractor's license.** However, the City reserves the right to award the Contract to a contractor with another class if the City determines that the license is proper for the work.

3. Contractor Registration Requirements

SB 854 amended the Labor Code to require all contractors bidding on public work to register with the Department of Industrial Relations (DIR) and to pay an annual fee. The registration requires contractors to provide the State with evidence of the contractors' compliance with a number of statutory requirements. The registration requirement took effect on July 1, 2014.

4. Bidder's Submittal and Contract Award Prohibited

Under California Labor Code section 1771.1, as amended by SB 854, unless registered with the DIR, a contractor may not bid, nor be listed as a subcontractor, for any bid proposal submitted for public work on or after March 1, 2015. Similarly, a public entity cannot award a public work contract to a non-registered contractor, effective April 1, 2015. Also refer to Section 5-3.1 of the Special Provisions.

5. Bidder Qualifications

Bidder Qualifications called for to be submitted at the time of bid include, but are not necessarily limited to:

- a. The Contractor shall have been in business under the same name and California Contractor's License for a minimum of 10 continuous years prior to the bid opening date for this project. The license used to satisfy this requirement shall be of the same type as required by the contract.
- b. The Contractor shall provide a minimum of 3 references for the construction of street rehabilitation projects which have been successfully completed in the State of California with a construction cost of at least \$2M. during the past 5 years
- c. The Contractor or the Subcontractor performing the construction of street rehabilitation shall have a minimum of 10 years' experience under the same name and California Contractor's License
- d. The Contractor shall perform above 50% of the contract with its own forces.

II. BIDDER RESPONSIBILITY

A responsible Bidder is a Bidder who has demonstrated the attribute of trustworthiness, as well as ability, fitness, capacity and experience to satisfactorily perform the work.

Bidders are notified that, in accordance with the Lomita Municipal Code, the City Council may determine whether the Bidder is responsible based on a review of the Bidder's performance on other contracts.

If, based on the provisions and criteria set forth in the Lomita Municipal Code, the Public Works Director proposes not to recommend the award of contract to the apparent low bidder, the Director shall notify the Bidder in writing of its intention to recommend to the City Council that the Council award the contract to the 2nd lowest responsible bidder. If the Bidder presents evidence in rebuttal to the recommendation, the Director shall evaluate the merits of such evidence, and based on that evaluation, make a recommendation to the City Council.

III. ADDENDA TO THE CONTRACT DOCUMENTS

The City may issue Addenda to the Contract Documents during the period of advertising for any reason. The Bidder shall acknowledge the receipt of the Addenda in their Bid. Failure of the Bidder to do so may result in the rejection of the Bid as non-responsive.

Addenda will be posted on the City website, but it shall be the bidder's responsibility to inquire for any addenda/updates to this Notice Inviting Bid prior to submitting their bid.

IV. PREPARATION OF THE BID

1. Examination of Site, Plans and Specifications

Prior to submitting a Bid, the Bidder shall examine the Plans and the Work site, carefully read the Specifications, and satisfy itself that it has the abilities and resources to complete the Work. The Bidder agrees that if it is awarded the Contract, no claim will be made against the City based on ignorance or misunderstanding of the provisions of the Contract Documents, the nature and amount of the work, and the physical and climatic conditions of the work site.

The Contractor shall have included in the contract price a sufficient sum to cover all items, including labor, materials, tools, equipment and incidentals, that are implied or required for the complete improvements as contemplated by the drawings, specifications, and other contract documents.

2. Estimated Quantities

The quantities shown in the Bid are approximate only. The Contractor will be paid for the actual quantities of work based on field measurements as provided for in these Specifications. The City reserves the right to increase or decrease the amount of any item or portion of work to be performed or materials furnished, or to delete any item, in accordance with the Specifications.

3. Bid Instructions and Submissions

The Bid shall be submitted on the Bid Proposal forms included with the Specifications. All Bid Documents must be completed, executed and submitted with the Bid by the Bidder.

Required seven (7) Bid Proposal Documents:

- 1) Bidder's Proposal
- 2) Contractor's Affidavit
- 3) Bid Bond (10%)
- 4) List of Subcontractors
- 5) Construction Project References
- 6) Violations of Federal or State Law
- 7) Disqualification or Debarment

All prices submitted will be considered as including any and all sales or use taxes. The Bid Proposal must be completed in ink or in typewritten form. The bid sum and all bid amounts on the form must be stated in words and numerals; in case of a conflict, words will take precedence.

In the case of discrepancy between unit bid price and total bid, the unit price shall prevail.

V. BID BOND

Each bid shall be accompanied by Bidder's Security in an amount equal to ten (10) percent of the bid amount, which security shall be lawful money of the United States of America and in one of the following forms: (i) cashier's check made payable to the City of Lomita, (ii) certified check made payable to the City of Lomita, or (iii) bid bond executed by an admitted surety insurer and made payable to the City of Lomita. City Bid Bond form must be used.

VI. NON-RESPONSIVE BIDS AND BID REJECTION

1. A Bid in which any one (1) of the required **eight (8) Bid proposal** documents are not completed, executed and submitted may be considered non-responsive and be rejected.
2. A Bid in which the Contract Unit Prices are unbalanced, which is incomplete or which shows alteration of form or irregularities of any kind, or which contains any additions or conditional or alternate Bids that are not called for, may be considered non-responsive and be rejected.

VII. AWARD OF CONTRACT

In accordance with the Lomita Municipal Code, the City Council reserves the right to reject any and all bids received, to take all bids under advisement for a period not-to-exceed ninety (90) days after date of opening thereof, to waive any informality or irregularity in the Bid, and to be the sole judge of the merits of material included in the respective bids received.

VIII. EXECUTION OF CONTRACT

After the Contract is awarded, the awardee shall execute the following eight (8) documents:

- 1) Contract - Public Works Agreement
- 2) Construction or Service Contract Endorsement
- 3) Performance Bond (100% of Bid price)
- 4) Labor and Material Bond (100% of Bid price)
- 5) Workers' Compensation Insurance Certificate
- 6) Verification of Insurance Coverage (Certificates and Endorsements)
- 7) Construction Permit Application Form
- 8) Business License Application Form

IX. APPRENTICESHIP EMPLOYMENT STANDARDS

The Contractor is directed to the provisions in Sections 1776, 1777.5 and 1777.6 of the California Labor Code concerning the employment of apprentices by the contractor or any subcontractor under them.

X. PERMITS, LICENSES AND PUBLIC WORKS AGREEMENT

The Contractor shall procure and execute all permits, licenses, pay all charges and fees, and give all notices necessary and incidental to the completion of the Work. The Contractor shall execute a Public Works Agreement. A no fee Excavation Permit will be issued by the City of Lomita for this project. The Contractor shall obtain a City of Lomita Business License.

XI. INSURANCE

The Contractor shall maintain Automobile Liability, General Liability and Workers' Compensation Insurance as specified in the Public Works Agreement included in the Project Specifications.

XII. PRE-BID INQUIRIES

A Bidder with a Pre-Bid Inquiry must e-mail their question(s) on or before **1:00 PM on Tuesday, Nov XX, 2023**, to the Project Manager, via email at PublicWorks@lomitacity.com. Questions received after this date may not be considered.

XIII. LABOR CODE – SB 854

The bidder shall be registered with the Department of Industrial Relations (DIR) in accordance with the provisions of Section 1771.1 of the California Labor Code, as amended by SB 854. No public work contract may be awarded to a non-registered contractor or subcontractor after April 15, 2015.

XIV. PREVAILING WAGE

Pursuant to Section 1773 of the Labor Code, the general prevailing wage rates in the county, or counties, in which the work is to be done have been determined by the Director of the California Department of Industrial Relations. These wages are set forth in the General Prevailing Wage Rates for this project, available from the California Department of Industrial Relations' Internet web site at <http://www.dir.ca.gov/DLSR/PWD>

XV. GUIDELINES DURING COVID-19 PANDEMIC

Contractors shall comply with all local, state and federal laws and regulations

including, but not limited to, the Governor's and Los Angeles County Health Officer's orders and guidance related to COVID-19, social distancing, and best practices.

Contractors are required to check with the latest guidelines of the Los Angeles County Public Works and the Los Angeles County Public Health for construction sites during the Coronavirus/COVID-19 pandemic.

SECTION C
BID DOCUMENTS

(TO BE SUBMITTED WITH BID PACKAGE)

BIDDER'S PROPOSAL

247TH STREET AREA WATER MAIN REPLACEMENT

Company: _____

Honorable Mayor and Members
of the Lomita City Council
Lomita, California

In accordance with the Notice Inviting Bids pertaining to the receiving of sealed proposals by the City Clerk of the City of Lomita for the above titled improvement, the undersigned hereby proposes to furnish all Work to be performed in accordance with the Plans, Specifications, Standard Drawings, and the Contract Documents, for the unit price or lump sum set forth in the following schedule.

The undersigned hereby acknowledges that he/she has examined the copies of the plans, specifications and all Contract Documents for this project and is fully aware of scope of the work.

The undersigned also acknowledges that he/she has examined the project site and locality where the work is to be performed and the legal requirements and conditions affecting the cost, progress and performance of the work in strict accordance with the Contract Documents.

The undersigned also acknowledges that timely completion of the project is important to the City. Therefore time being of the essence, he/she proposes that the work will be commenced and will be completed within the time specified in the Notice Inviting Bids.

Specification or Items not indicated on Bid Form: The Contractor is to accommodate those portions of the work required by the specifications or contract documents, whose method of payment is not included in other bid items elsewhere.

In addition, bid items costs associated with bonds, insurance, traffic control, labor, equipment, materials, overhead, profits, any and all other indirect costs shall be considered full compensation for each bid item.

All work shall be completed within 80 working days from the date the notice to proceed is issued by the Engineer.

PROJECT BID SCHEDULE

Item No.	Item Description	Qty.	Unit	Unit Price	Total Bid
1	Mobilization and demobilization.	1	LS	\$	\$
2	Traffic control.	1	LS	\$	\$
3	Excavation safety measures.	1	LS	\$	\$
4	Construction surveying.	1	LS	\$	\$
5	Water pollution control (includes BMP installation and maintenance).	1	LS	\$	\$
6	Re-establish survey monuments.	1	LS	\$	
7	Sawcutting.	1	LS	\$	\$
8	Construct new 8" PVC C900 DR 18 water main, including but not limited to furnishing of fittings and end caps. Construction shall be per City of Lomita Standards and include trenching, bedding, and backfill.	670	LF	\$	\$
9	Construct new 8" PVC C900 DR 14 water main, including but not limited to furnishing of fittings and end caps. Construction shall be per City of Lomita Standards and include trenching, bedding, and backfill.	3,260	LF	\$	\$
10	Provide and install 8" gate valve.	18	EA	\$	\$
11	Furnish and install 1" water service, connect to existing meter and box.	32	EA	\$	\$
12	Cut existing water main and remove interfering portions. Plug with concrete and abandon.	1	LS	\$	\$
13	Connect to existing water main (includes installation of transition coupling, if required per plans).	5	EA	\$	\$

14	Construct AC pavement base course including subgrade and base preparation per City of Lomita trench detail.	2,430	SF	\$	\$
15	Cold plane asphalt concrete (2") depth per City of Lomita standards.	270	SY	\$	\$
16	Construct AC pavement cap per City of Lomita trench detail.	30	TON	\$	\$
17	Construct AC pavement base course including subgrade and base preparation per City of Los Angeles trench detail.	7,570	SF	\$	\$
18	Cold plane asphalt concrete (2") depth per City of Los Angeles standards.	841	SY	\$	\$
19	Construct AC pavement cap per City of Los Angeles trench detail.	95	TON	\$	\$
20	Construct AC pavement base course including subgrade and base preparation per Caltrans trench detail.	815	SF	\$	\$
21	Cold plane asphalt concrete (2") depth per Caltrans standards.	91	SY	\$	\$
22	Construct AC pavement cap per City of Caltrans trench detail.	10	TON	\$	\$
23	Construct PCC bus pad including dowel installation, subgrade and base preparation per Caltrans standards.	795	SF	\$	\$
24	Replace damaged pavement striping, markings, reflectors, legends.	1	LS	\$	\$
25	Soil sampling if hazardous soil is encountered (As Needed Only)	5	EA	\$	\$
26	Excavation, haul away and disposal of hazardous soil if encountered (As Needed Only)	180	TN	\$	\$
TOTAL BID (Items 1 through 26)				\$	

TOTAL BID:

(Figures)

(Words)

***BID MAY BE REJECTED IF TOTAL IS NOT SHOWN IN FIGURES AND WORDS.**

The undersigned furthermore agrees to enter into and execute a contract, with necessary bonds, at the unit prices set forth herein and in case of default in executing such contract, with necessary bonds, the check or bond accompanying this bid and the money payable thereon shall be forfeited thereby to and remain the property of the City of Lomita.

The above unit prices include all work appurtenant to the various items as outlined in the Specifications and all work or expense required for the satisfactory completion of said items. In case of discrepancies between unit prices and totals, the unit prices shall govern.

The undersigned declares that it has carefully examined the Plans, Specifications, and Contract Documents, and has investigated the site of the work and is familiar with the conditions thereon.

Contractor _____

Date: _____ By: _____

Contractor's State License No.: _____ Class _____ Exp. Date: _____

Contractor's Address: _____

Phone: _____

CONTRACTOR'S AFFIDAVIT

STATE OF CALIFORNIA }
 }
COUNTY OF _____ }

_____, being first duly sworn, deposes and says:

1. That he is the _____
 Title
of _____
 (Name of Partnership, Corporation, or Sole Proprietorship)

hereinafter called "Contractor," who has submitted to the City of Lomita a proposal for: **247TH STREET AREA WATER MAIN REPLACEMENT**

2. That said proposal is genuine; that the same is not sham; that all statement of facts therein are true;
3. That such proposal was not made in the interest or behalf of any person, partnership, company, association, organization or corporation not named or disclosed;
4. That the Contractor did not, directly or indirectly, induce, solicit or agree with anyone else to submit a false or sham bid, to refrain from bidding, or to withdraw the bid, to raise or fix the bid price of the Contractor or anyone else, or to raise or fix any overhead, profit or cost element of the Contractor's price or the price of anyone else; and did not attempt to induce action prejudicial to the interest of the City of Lomita, or of any other bidder, or anyone else interested in the proposed contract;
5. That the Contractor has not in any manner sought by collusion to secure for itself an advantage over any other bidder or to induce action prejudicial to the interests of the City of Lomita, or of any other bidder or of anyone else interested in the proposed contract;
6. That the Contractor has not accepted any bid from any subcontractor or materialman through any bid depository, the bylaws, rules or regulations of which prohibit or prevent the Contractor from considering any bid from any subcontractor or materialman, which is not processed through said bid depository, or which prevent any subcontractor or materialman from bidding to any contractor who does not use the facilities of or accept bids from or through such bid depository;

7. That the Contractor did not, directly or indirectly, submit the Contractor's bid price or any breakdown thereof, or the contents thereof, or divulge information or data relative thereto, to any corporation, partnership, company, association, organization, bid depository, or to any member or agent thereof, or to any individual or group of Individuals, except to the City of Lomita, or to any person or persons who have a partnership or other financial interest with said Contractor in its business.

Dated this _____ day of _____, 2023

Subscribed and Sworn to

Contractor

Title

before me this _____ day of _____, 2023.

Notary Public in and for said
County and State.
(Seal)

BID BOND (10%)

KNOW ALL MEN BY THESE PRESENTS: That we, _____

as principal, and _____

as sureties, are held and firmly bound unto the City of Lomita, State of California, in the penal sum of _____ dollars (\$_____), for the payment whereof we hereby bind ourselves, our successors, heirs, executors or administrators jointly and severally, firmly by these presents.

The condition of this obligation is such that, whereas the above bounded principal is about to file with and submit to the City of Lomita a bid or proposal for the performance of certain work as required in the City of Lomita, said work being: **247TH STREET AREA WATER MAIN REPLACEMENT** in compliance with the Specifications therefor under an invitation of said City contained in a notice or advertisement for bids or proposals; now if the bid or proposal of the said principal shall be accepted and if the said work be thereupon awarded to the principal by said City and if the said principal shall enter into a contract with the said City in accordance with said bid or proposal, or if the bid or proposal of the said principal is rejected, then this bond shall be void and of no effect and otherwise in full force and effect.

WITNESS our hands this _____ day of _____, 20____.

Principal

Surety/Attorney-in-Fact

Signature

Name: _____
Local Address: _____

Phone No.: _____
Fax No.: _____

LIST OF SUBCONTRACTORS

247TH STREET AREA WATER MAIN REPLACEMENT

The Bidder is required to fill in the following blanks in accordance with the provisions of the Subletting and Subcontracting Fair Practices Act (Chapter 2 of Division 5, Title 1 of the Government Code of the State of California) and should familiarize itself with Section 2-3 of the Standard Specifications.

Name Under Which Subcontractor is Licensed: _____

License Number: _____

Address of Office, Mill or Shop: _____

Specific Description of Sub-Contract: _____

Name Under Which Subcontractor is Licensed: _____

License Number: _____

Address of Office, Mill or Shop: _____

Specific Description of Sub-Contract: _____

Name Under Which Subcontractor is Licensed: _____

License Number: _____

Address of Office, Mill or Shop: _____

Specific Description of Sub-Contract: _____

Name Under Which Subcontractor is Licensed: _____

License Number: _____

Address of Office, Mill or Shop: _____

Specific Description of Sub-Contract: _____

Subcontractors listed in accordance with the provisions of Section 2-3 must be properly licensed under the laws of the State of California for the type of work which they are to perform. Do not list alternate subcontractors for the same work.

CONSTRUCTION PROJECT REFERENCE

(Work similar in magnitude and degree of difficulty completed by Contractor within the past three [3] years.)

1. Name (Firm/Agency): _____
Address: _____
Contact Person: _____ Telephone No.: _____
Title of Project: _____
Project Location: _____
Date of Completion: _____ Contract Amount: \$ _____

2. Name (Firm/Agency): _____
Address: _____
Contact Person: _____ Telephone No.: _____
Title of Project: _____
Project Location: _____
Date of Completion: _____ Contract Amount: \$ _____

3. Name (Firm/Agency): _____
Address: _____
Contact Person: _____ Telephone No.: _____
Title of Project: _____
Project Location: _____
Date of Completion: _____ Contract Amount: \$ _____

VIOLATIONS OF FEDERAL, STATE OR LOCAL LAWS

1. Has your firm or its officers been assessed any penalties by an agency for noncompliance or violations of Federal, State or Local labor laws and/or business or licensing regulations within the past five (5) years relating to your construction projects?

Yes/No: _____ Federal/State: _____

If "yes," identify and describe, (including agency and status): _____

Have the penalties been paid? Yes/No: _____

2. Does your firm or its officers have any ongoing investigations by any public agency regarding violations of the State Labor Code, California Business and Professions Code or State Licensing Laws?

Yes/No: _____ Code/Laws: _____ Section/Article: _____

If "yes," identify and describe, (including agency and status): _____

DISQUALIFICATION OR DEBARMENT

Has your firm, any officer of your firm, or any employee who has a proprietary interest in your firm ever been disqualified, removed, or otherwise prevented from bidding on, performing work on, or completing a federal, state or local project because of a violation of law or a safety regulation? Yes/No: _____. If yes, provide the following information (if more than once, use separate sheets):

Date: _____ Entity: _____

Location: _____

Reason: _____

Provide Status and any Supplemental Statement: _____

Has your firm been reinstated by this entity? Yes/No: _____

SECTION D
CONTRACT DOCUMENTS

**TO BE SUBMITTED
WITHIN TWENTY ONE (21) CALENDAR DAYS
AFTER AWARD OF CONTRACT**



CITY OF LOMITA PUBLIC WORKS AGREEMENT

CITY OF LOMITA PUBLIC WORKS AGREEMENT

This Public Works Agreement ("Agreement") is made and entered into as of the date executed by the City Manager and attested to by the City Clerk, by and between _____ (hereinafter referred to as "CONTRACTOR") and the City of Lomita, California, a municipal corporation (hereinafter referred to as "CITY").

RECITALS

- A. Pursuant to the Notice Inviting Sealed Bids for **247TH STREET AREA WATER MAIN REPLACEMENT**, bids were received, publicly opened, and declared on the date specified in the notice.
- B. On **XXXX XX, 2023**, Lomita's City Council declared CONTRACTOR to be the lowest responsible bidder and accepted the bid of CONTRACTOR.
- C. The City Council has authorized the City Manager to execute a written contract with CONTRACTOR for furnishing labor, equipment and material for the **247TH STREET AREA WATER MAIN REPLACEMENT** Project in the City of Lomita.

NOW, THEREFORE, in consideration of the foregoing and the mutual covenants herein contained, it is agreed:

1. GENERAL SCOPE OF WORK: CITY agrees to engage CONTRACTOR and CONTRACTOR agrees to furnish all necessary labor, tools, materials, appliances, and equipment for and do the work for the 247th Street Area Water Main Replacement Project in the City of Lomita. The work shall be performed in accordance with the Plans and Specifications dated XXXX 2023 (the "Specifications" attached as Exhibit A) and in accordance with bid prices set forth in CONTRACTOR'S Bid Proposal (attached as Exhibit B) and in accordance with the instructions of the City Engineer.
2. INCORPORATED DOCUMENTS TO BE CONSIDERED COMPLEMENTARY: The contract documents for the aforesaid project, a complete set of which is on file with the Lomita City Clerk's Office, shall consist of the Notice Inviting Bids, Instructions to Bidders, Bid Proposal, Builders General Provisions, Standard Specifications, Special Provisions, and all referenced specifications, details, standard drawings, and appendices; together with this Agreement and all required bonds, insurance certificates, permits, notices and affidavits; and also, including any and all addenda or supplemental agreements clarifying, amending,

or extending the work contemplated as may be required to insure its completion in an acceptable manner. All of the provisions of said contract documents are made a part hereof as though fully set forth herein. This contract is intended to require a complete and finished piece of work and anything necessary to complete the work properly and in accordance with the law and lawful governmental regulations shall be performed by CONTRACTOR whether set out specifically in the contract or not. Should it be ascertained that any inconsistency exists between the aforesaid documents and this written agreement, the provisions of this Agreement, the Builders General Provisions and the Standard Specifications, in that order, shall control. Collectively, these contract documents constitute the complete agreement between CITY and CONTRACTOR and supersede any previous agreements or understandings.

3. **COMPENSATION:** CONTRACTOR agrees to receive and accept the prices set forth in its Bid Proposal as full compensation for furnishing all materials, performing all work, and fulfilling all obligations hereunder. Said compensation shall cover all expenses, losses, damages, and consequences arising out of the nature of the work during its progress or prior to its acceptance including those for well and faithfully completing the work and the whole thereof in the manner and time specified in the aforesaid contract documents; and also including those arising from actions of the elements, unforeseen difficulties or obstructions encountered in the prosecution of the work, suspension or discontinuance of the work, and all other unknowns or risks of any description connected with the work.
4. **TIME OF PERFORMANCE:** CONTRACTOR agrees to complete the work within **80 working days** from the date of the notice to proceed. By signing this Agreement, CONTRACTOR represents to CITY that the contract time is reasonable for completion of the work and that CONTRACTOR will complete such work within the contract time. In accordance with Government Code Section 53069.85, CONTRACTOR agrees to forfeit and pay CITY as liquidated damages, not as a penalty, the sum of \$1000.00 per day for each and every day of unauthorized delay beyond the completion date, which amount shall be deducted from any payments due or to become due the CONTRACTOR.
5. **PREVAILING WAGES:**

Pursuant to Labor Code § 1720, and as specified in 8 California Code of Regulations § 16000, CONTRACTOR must pay its workers prevailing wages. It is CONTRACTOR's responsibility to interpret and implement any prevailing wage requirements and CONTRACTOR agrees to pay any penalty or civil damages resulting from a violation of the prevailing wage laws.

In accordance with Labor Code § 1773.2, copies of the prevailing rate of per diem wages are available upon request from CITY's Engineering Division or the website for State of California Prevailing wage determination at <http://www.dir.ca.gov/DLSR/PWD>. CONTRACTOR must post a copy of the prevailing rate of per diem wages at the job site.

CITY directs CONTRACTOR's attention to Labor Code §§ 1777.5, 1777.6 and 3098 concerning the employment of apprentices by CONTRACTOR or any subcontractor.

Labor Code § 1777.5 requires CONTRACTOR or subcontractor employing tradesmen in any apprenticeship occupation to apply to the joint apprenticeship committee nearest the site of the public works project and which administers the apprenticeship program in that trade for a certificate of approval. The certificate must also fix the ratio of apprentices to journeymen that will be used in the performance of the contract. The ratio of apprentices to journeymen in such cases will not be less than one to five except:

When employment in the area of coverage by the joint apprenticeship committee has exceeded an average of 15 percent in the 90 days before the request for certificate, or

When the number of apprentices in training in the area exceeds a ratio of one to five, or

When the trade can show that it is replacing at least 1/30 of its membership through apprenticeship training on an annual basis state-wide or locally, or

When CONTRACTOR provides evidence that CONTRACTOR employs registered apprentices on all of his contracts on an annual average of not less than one apprentice to eight journeymen.

CONTRACTOR is required to make contributions to funds established for the administration of apprenticeship programs if CONTRACTOR employs registered apprentices or journeymen in any apprenticeable trade on such contracts and if other contractors on the public works site are making such contributions.

CONTRACTOR and any subcontractor must comply with Labor Code §§ 1777.5 and 1777.6 in the employment of apprentices.

Information relative to apprenticeship standards, wage schedules and other requirements may be obtained from the Director of Industrial Relations, ex-officio the Administrator of Apprenticeship, San Francisco, California, or from the Division of Apprenticeship Standards and its branch offices.

CONTRACTOR and its subcontractors must keep an accurate certified payroll records showing the name, occupation, and the actual per diem wages paid to each worker employed in connection with this Agreement. The record will be kept open at all reasonable hours to the inspection of the body awarding the contract and to the Division of Labor Law Enforcement. If requested by CITY, CONTRACTOR must provide copies of the records at its cost.

6. LEGAL HOURS OF WORK: Eight (8) hours of labor shall constitute a legal day's work for all workmen employed in the execution of this contract, and CONTRACTOR and any subcontractor under it shall comply with and be governed by the laws of the State of California having to do with working hours

set forth in Division 2, Part 7, Chapter 1, Article 3 of the Labor Code of the State of California as amended.

CONTRACTOR shall forfeit, as a penalty to CITY, twenty-five dollars (\$25.00) for each laborer, workman or mechanic employed in the execution of the contract, by him or any subcontractor under it, upon any of the work hereinbefore mentioned, for each calendar day during which the laborer, worker or mechanic is required or permitted to labor more than eight (8) hours in violation of the Labor Code.

7. TRAVEL AND SUBSISTENCE PAY: CONTRACTOR agrees to pay travel and subsistence pay to each worker needed to execute the work required by this Agreement as such travel and subsistence payments are defined in the applicable collective bargaining agreements filed in accordance with Labor Code Section 1773.8.
8. CONTRACTOR'S LIABILITY: The City of Lomita and its officers, agents and employees ("Indemnitees") shall not be answerable or accountable in any manner for any loss or damage that may happen to the work or any part thereof, or for any of the materials or other things used or employed in performing the work; or for injury or damage to any person or persons, either workers or employees of CONTRACTOR, of its subcontractors or the public, or for damage to adjoining or other property from any cause whatsoever arising out of or in connection with the performance of the work. CONTRACTOR shall be responsible for any damage or injury to any person or property resulting from defects or obstructions or from any cause whatsoever.

CONTRACTOR will indemnify Indemnitees against and will hold and save Indemnitees harmless from any and all actions, claims, damages to persons or property, penalties, obligations or liabilities that may be asserted or claimed by any person, firm, entity, corporation, political subdivision, or other organization arising out of or in connection with the work, operation, or activities of CONTRACTOR, its agents, employees, subcontractors or invitees provided for herein, whether or not there is concurrent passive negligence on the part of any Indemnitee. In connection therewith:

- a. CONTRACTOR will defend any action or actions filed in connection with any such claims, damages, penalties, obligations or liabilities and will pay all costs and expenses, including attorneys' fees, expert fees and costs incurred in connection therewith.
- b. CONTRACTOR will promptly pay any judgment rendered against CONTRACTOR or Indemnitees covering such claims, damages, penalties, obligations and liabilities arising out of or in connection with such work, operations or activities of CONTRACTOR hereunder, and CONTRACTOR agrees to save and hold the Indemnitees harmless therefrom.
- c. In the event Indemnitees are made a party to any action or proceeding filed or prosecuted against CONTRACTOR for damages or other claims arising out of or in connection with the work, operation or activities hereunder, CONTRACTOR agrees to pay to Indemnitees and any all costs and expenses incurred by Indemnitees in such action or proceeding together with reasonable attorneys' fees.

CONTRACTOR'S obligations under this section apply regardless of whether or not such claim, charge, damage, demand, action, proceeding, loss, stop notice, cost, expense, judgment, civil fine or penalty, or liability was caused in part or contributed to by an Indemnitee. However, without affecting the rights of CITY under any provision of this agreement, Contractor shall not be required to indemnify and hold harmless CITY for liability attributable to the active negligence of CITY, provided such active negligence is determined by agreement between the parties or by the findings of a court of competent jurisdiction. In instances where CITY is shown to have been actively negligent and where CITY active negligence accounts for only a percentage of the liability involved, the obligation of Contractor will be for that entire portion or percentage of liability not attributable to the active negligence of City.

So much of the money due to CONTRACTOR under and by virtue of the contract as shall be considered necessary by CITY may be retained by CITY until disposition has been made of such actions or claims for damages as aforesaid.

It is expressly understood and agreed that the foregoing provisions are intended to be as broad and inclusive as is permitted by the law of the State of California. This indemnity provision shall survive the termination of the Agreement and is in addition to any other rights or remedies which Indemnitees may have under the law.

This indemnity is effective without reference to the existence or applicability of any insurance coverage which may have been required under this Agreement or any additional insured endorsements which may extend to Indemnitees.

CONTRACTOR, on behalf of itself and all parties claiming under or through it, hereby waives all rights of subrogation and contribution against the Indemnitees, while acting within the scope of their duties, from all claims, losses and liabilities arising out of or incident to activities or operations performed by or on behalf of the CONTRACTOR regardless of any prior, concurrent, or subsequent passive negligence by the Indemnitees.

9. THIRD PARTY CLAIMS. In accordance with Public Contracts Code § 9201, CITY will promptly inform CONTRACTOR regarding third-party claims against CONTRACTOR, but in no event later than ten (10) business days after CITY receives such claims. Such notification will be in writing and forwarded in accordance with the "Notice" section of this Agreement. As more specifically detailed in the contract documents, CONTRACTOR agrees to indemnify and defend the City against any third-party claim.

10. WORKERS COMPENSATION: In accordance with California Labor Code Sections 1860 and 3700, CONTRACTOR and each of its subcontractors will be required to secure the payment of compensation to its employees. In accordance with the provisions of California Labor Code Section 1861, CONTRACTOR, by signing this contract, certifies as follows: "I am aware of the provisions of Section 3700 of the Labor Code which require every employer to be insured against liability for worker's compensation or to undertake self-insurance in accordance with the provisions of that code, and I will comply with such provisions before commencing the performance of the work of this contract.

11. INSURANCE: With respect to performance of work under this contract, CONTRACTOR shall maintain and shall require all of its subcontractors to maintain insurance as required in the Builders General Provisions.
12. ASSIGNMENT: This Agreement is not assignable nor the performance of neither party's duties delegable without the prior written consent of the other party. Any attempted or purported assignment or delegation of any of the rights of obligations of either party without the prior written consent of the other shall be void and of no force and effect.
13. INDEPENDENT CONTRACTOR: CONTRACTOR is and shall at all times remain as to the CITY, a wholly independent contractor. Neither the CITY nor any of its agents shall have control of the conduct of CONTRACTOR or any of CONTRACTOR'S employees, except as herein set forth. CONTRACTOR shall not at any time or in any manner represent that it or any of its agents or employees are in any manner agents or employees of CITY.
14. TAXES: CONTRACTOR is responsible for paying all retail sales and use, transportation, export, import, special or other taxes and duties applicable to, and assessable against any work, materials, equipment, services, processes and operations incidental to or involved in this contract. CONTRACTOR is responsible for ascertaining and arranging to pay them. The prices established in the contract shall include compensation for any taxes CONTRACTOR is required to pay by laws and regulations in effect at the bid opening date.
15. LICENSES: CONTRACTOR represents and warrants to CITY that it has all licenses, permits, qualifications, insurance, and approvals of whatsoever nature which are legally required of CONTRACTOR to practice its profession. CONTRACTOR represents and warrants to CITY that CONTRACTOR shall, at its sole cost and expense, keep in effect or obtain at all times during the term of this Agreement any licenses, permits, insurance, and approvals which are legally required of CONTRACTOR to practice its profession. CONTRACTOR shall maintain a City of Lomita business license, if required under CITY ordinance.
16. RECORDS: CONTRACTOR shall maintain accounts and records, including personnel, property, and financial records, adequate to identify and account for all costs pertaining to this Agreement and such other records as may be deemed necessary by CITY or any authorized representative, and will be retained for three years after the expiration of this Agreement. All such records shall be made available for inspection or audit by CITY at any time during regular business hours.
17. SEVERABILITY. If any portion of these contract documents are declared by a court of competent jurisdiction to be invalid or unenforceable, then such portion will be deemed modified to the extent necessary in the opinion of the court to render such portion enforceable and, as so modified, such portion and the balance of this Agreement will continue in full force and effect provided that it does not frustrate the mutual intent of the parties herein.
18. WHOLE AGREEMENT: This Agreement supersedes any and all other agreements either oral or written, between the parties and contains all of the

covenants and agreements between the parties pertaining to the work of improvements described herein. Each party to this Agreement acknowledges that no representations, inducements, promises, or agreements, orally or otherwise, have been made by any party, or anyone acting on behalf of any party, which are not embodied herein, and that any other agreement, statements, or promise not contained in this Agreement shall not be valid or binding. Any modification of this Agreement will be effective only if signed by the party to be charged.

19. AUTHORITY: CONTRACTOR affirms that the signatures, titles, and seals set forth hereinafter in execution of this Agreement represent all individuals, firm members, partners, joint ventures, and/or corporate officers having a principal interest herein. Each party warrants that the individuals who have signed this Agreement have the legal power, right, and authority to make this Agreement and to bind each respective party. This Agreement may be modified by written amendment. CITY's City Manager may execute any such amendment on CITY's behalf.
20. NOTICES: All notices permitted or required under this Agreement shall be in writing and shall be deemed made when delivered to the applicable party's representative as provided in this Agreement. Additionally, such notices may be given to the respective parties at the following addresses, or at such other addresses as the parties may provide in writing for this purpose.

Such notices shall be deemed made when personally delivered or when mailed forty-eight (48) hours after deposit in the U.S. mail, first-class postage prepaid, and addressed to the party at its applicable address. Courtesy copies of notices may be sent via electronic mail, provided that the original notice is deposited in the U.S. mail or personally delivered as specified in this Section.

CITY OF LOMITA, CA

24300 Narbonne Avenue, Lomita, CA 90717

Attention:

CONTRACTOR:

Attention:

21. DISPUTES. Disputes arising from this Agreement will be determined in accordance with the contract documents and Public Contracts Code §§ 10240-10240.13.
22. NON-DISCRIMINATION: No discrimination shall be made in the employment of persons in the work contemplated by this Agreement because of race, religion, color, medical condition, sex, sexual orientation, national origin, political affiliation or opinion, or pregnancy or pregnancy-related condition. A violation of this

section exposes CONTRACTOR to the penalties provided for in Labor Code Section 1735.

23. NO THIRD PARTY BENEFICIARY. This Agreement and every provision herein is for the exclusive benefit of the Contractor and the City and not for the benefit of any other party. There will be no incidental or other beneficiaries of any of the Contractor's or the City's obligations under this Contract.
24. TIME IS OF ESSENCE. Time is of the essence for each and every provision of the Contract Documents.
25. ACCEPTANCE OF FACSIMILE OR ELECTRONIC SIGNATURES. The Parties agree that this Agreement will be considered signed when the signature of a party is delivered by facsimile transmission, scanned and delivered via electronic mail, or delivered using digital signature technology approved by CITY. Such facsimile or electronic signatures will be treated in all respects as having the same effect as an original signature.
26. GOVERNING LAW: This Agreement shall be governed by the laws of the State of California, and exclusive venue for any action involving this Agreement will be in Los Angeles County.

IN WITNESS WHEREOF, the parties hereto have executed this Agreement with all the formalities required by law on the respective dates set forth opposite their signatures.

State of California

CONTRACTOR'S License No. _____

CONTRACTOR

_____ By: _____
DATE

CONTRACTOR'S Business Phone _____

Emergency Phone at which CONTRACTOR can be reached at any time: _____

CITY OF LOMITA, CALIFORNIA

_____ By: _____
DATE **Ryan Smoot, CITY MANAGER**

ATTEST:

_____ By: _____
DATE **Kathleen Horn Gregory, CITY CLERK**

APPROVED AS TO FORM:

_____ By: _____
DATE **Trevor Rusin, CITY ATTORNEY**

Attachments: Exhibit A: Contractor's Bid Proposal

**CITY OF LOMITA
CONSTRUCTION OR SERVICE CONTRACT ENDORSEMENT**

To be attached to and made a part of all policies insuring the liability of any person, firm or corporation performing services under contract for the City of Lomita.

Notwithstanding any inconsistent expression in the policy to which this endorsement is attached, or in any other endorsement now or hereafter attached thereto, or made a part thereof, the protection afforded by said policy shall:

1. Include the City of Lomita as an additional insured. (To include the elected officials, appointed officials, and employees.)
2. Indemnify and save harmless the City of Lomita against any and all claims resulting from the undertaking specified in the contract known as:

**PROPOSAL, SPECIFICATIONS, BOND AND AFFIDAVIT
FOR
247TH STREET AREA WATER MAIN REPLACEMENT**

This hold harmless assumption on the part of the underwriters shall include all costs of investigation and defense, including claims based on damage to substructures not shown, not located on the plans, or shown incorrectly.

3. Not be cancelled except by notice to the City Attorney of the City of Lomita at least thirty (30) days prior to the date of cancellation.
4. Provide single limit for Bodily Injury Liability and Property Damage Liability combined, \$3,000,000 each Occurrence, and \$5,000,000 Aggregate.
5. Limited classifications, restricting endorsements, exclusions or other special provisions contained in the policy shall not act to limit the benefits of coverage as they shall apply to the City of Lomita as enumerated in this endorsement. However, nothing herein contained shall affect any rights of the insurer against the insured.
6. It is further expressly agreed by and between the parties hereto that the following two provisions, (a) and (b), are a part of this contract:
 - (a) That the CONTRACTOR specifically agrees to comply with applicable provisions of Section 1777.5 of the Labor Code relating to the employment by contractor or subcontractor under it, of journeyman or apprentices, or workmen, in any apprenticeable craft or trade.
 - (b) By my signature hereunder, as CONTRACTOR, I certify that I am aware of the provisions of Section 3700 of the Labor Code which requires every employer to be insured against liability for Workers' Compensation or to undertake self-insurance in accordance with the provisions of that code,

and I will comply with such provisions before commencing the performance of the work of this contract.

The limits of liability as stated in this endorsement apply to the insurance afforded by this endorsement notwithstanding that the policy may have lower limits of liability applying elsewhere in the policy.

Duly Authorized Agent

Attached to and forming part of

Policy No.: _____

of the: _____

Date: _____

Expiration Date: _____

PERFORMANCE BOND

KNOW ALL MEN BY THESE PRESENTS:

That we, _____ as Principal(s) and _____ a corporation, incorporated, organized, and existing under the laws of the State of _____, and authorized to execute bonds and undertakings and to do a general surety business in the State of California, as Surety, are jointly and severally held and firmly bound unto the City of Lomita, a municipal corporation, located in the County of Los Angeles, State of California, in the full and just sum of: _____ Dollars (\$ _____), lawful money of the United States of America, for the payment of which sum, well and truly to be made, we bind ourselves and our respective heirs, executors, administrators, representative, successors and assigns, jointly and severally, firmly by these presents.

THE CONDITION OF THIS OBLIGATION IS SUCH, that: **WHEREAS**, said Principal(s) have/has entered into, or are/is about to enter into, a certain written contract or agreement, dated as of the _____ day of _____, 20____, with the said City of Lomita for the **247TH STREET AREA WATER MAIN REPLACEMENT**, all as is more specifically set forth in said contract or agreement, a full, true and correct copy of which is hereunto attached, and hereby referred to and by this reference incorporated herein and made a part hereof;

NOW, THEREFORE, if the said Principal(s) shall faithfully and well and truly do, perform and complete, or cause to be done, performed and complete, each and all of the covenants, terms, conditions, requirements, obligations, acts and things, to be met, done or performed by said Principal(s), including any guarantee period as set forth in, or required by, said contract or agreement, all at and within the time or times, and in the manner as therein specified and contemplated, then this bond and obligation shall be null and void; otherwise it shall be and remain in full force, virtue and effect.

The said Surety, for value received, hereby stipulates and agrees that no amendment, change, extension of time, alteration or addition to said contract or agreement, or of any feature or item or items of performance required therein or thereunder, shall in any manner affect its obligations on or under this bond; and said Surety does hereby waive notice of any such amendment, change, extension of time, alteration, or addition to said contract or agreement, and of any feature or item or items of performance required therein or thereunder.

PERFORMANCE BOND (CONTINUED)

In the event any suit, action or proceedings is instituted to recover on this bond or obligation, said Surety will pay, and does hereby agree to pay, as attorney's fees for said City, such sum as the Court in any such suit, action or proceeding may adjudge reasonable.

EXECUTED, SEALED AND DATED this _____ day of _____, 20_____.

CORPORATE SEAL

PRINCIPAL(S):

BY _____

BY _____

CORPORATE SEAL

SURETY:

BY _____

LABOR AND MATERIAL BOND

KNOW ALL MEN BY THESE PRESENTS:

That we, _____ as Principal(s) and _____ a corporation, incorporated, organized, and existing under the laws of the State of _____, and authorized to execute bonds and undertakings and to do a general surety business in the State of California, as Surety, are jointly and severally held and firmly bound unto:

- (a) The State of California for the use and benefit of the State Treasurer, as ex-officio Treasurer and custodian of the Unemployment Fund of said State; and
- (b) The City of Lomita, California; and
- (c) Any and all persons who do or perform or who did or performed work or labor upon or in connection with the work or improvement referred to in the contract or agreement hereinafter mentioned; and
- (d) Any and all materialmen, persons, companies, firms, association, or corporations, supplying or furnishing any materials, provisions, provender, transportation, appliances or power, or other supplies used in, upon, for or about or in connection with the performance of the work or improvement contracted to be executed, done, made or performed under said contract or agreement; and
- (e) Any and all persons, companies, firms, associations, or corporations furnishing, renting, or hiring teams, equipment, implements or machinery for, in connection with, or contributing to, said work to be done or improvement to be made under said contract or agreement; and
- (f) Any and all persons, companies, firms, associations, or corporations who supply both work and materials;

and whose claim has not been paid by said Principal(s), in full and just sum of _____ Dollars (\$_____), lawful money of the United States of America, for the payment of which will and truly to be made, said Principal(s) and said Surety do hereby bind themselves and their respective heirs, executors, administrators, representatives, successors and assigns, jointly and severally, firmly by these presents.

LABOR AND MATERIAL BOND (CONTINUED)

THE CONDITION OF THE FOREGOING OBLIGATION IS SUCH, THAT: WHEREAS, said Principal(s) have/has entered into or are/is about to enter into a certain written contract or agreement, dated as of the _____ day of _____ 20 ____, with the City of Lomita for the **247TH STREET AREA WATER MAIN REPLACEMENT**, all as is more specifically set forth in said contract or agreement, a full, true and correct copy of which is hereunto attached, and hereby referred to and by this reference incorporated herein and made a part hereof;

NOW, THEREFORE, if the said Principal(s) (or any of his/her, its, or their subcontractors) under said contract or agreement fails or fail to pay:

- (1) For any materials, provisions, provender, transportation, appliances, or power, or other supplies; or
- (2) For the hire of any teams, equipment, implements, or machinery; or
- (3) For any work or labor; supplies, furnished, provided, used, done or performed in, upon, for or about or in connection with the said work or improvement; or
- (4) For amounts due under the Unemployment Insurance Act of the State of California with respect to such work or improvement;

the Surety on this bond will pay the same in an amount not exceeding the sum hereinabove specified in this bond; and, also, in case suit is brought upon this bond, said Surety will (and does hereby agree to) pay a reasonable attorney's fee, to be fixed and taxed as costs, and included in the judgment therein rendered.

This bond shall (and it is hereby made to) insure to the benefit of any and all persons entitled to file claims under Section 1192.1 of the Code of Civil Procedure of the State of California, so as to give a right of action to them or their assigns in any suit brought upon this bond, all as contemplated under the provisions of Section 4205 of the Government Code, and of Chapter 1 of Title 4 of Part 3 of the Code of Civil Procedure, of the State of California.

This bond is executed and filed in connection with said contract or agreement hereunto attached to comply with each and all of the provisions of the laws of the State of California above mentioned or referred to, and of all amendments thereto, and the obligors so intend and do hereby bind themselves accordingly.

LABOR AND MATERIAL BOND (CONTINUED)

The said Surety, for value received, hereby stipulates and agrees that no amendment, change, extension of time, alteration, or addition to said contract or agreement, or of any feature or item or items of performance required therein or thereunder, shall in any manner affect its obligations on or under this bond; and said Surety does hereby waive notice of any such amendment, change, extension of time, alteration, or addition to said contract or agreement, and of any feature or item or items of performance required therein or thereunder.

EXECUTED, SEALED AND DATED this _____ day of _____, 20 ____

CORPORATE SEAL

PRINCIPAL:

BY _____

CORPORATE SEAL

SURETY:

BY _____

WORKERS' COMPENSATION INSURANCE CERTIFICATION

247TH STREET AREA WATER MAIN REPLACEMENT

In compliance with Section 7-4 of the Standard Specifications, the CONTRACTOR shall complete and submit the following certification with a Certificate of Insurance before execution of the contract.

I am aware of, and will comply with, Section 3700 of the Labor Code, requiring every employer to be insured against liability for Workers' Compensation or to undertake self-insurance before commencing any of the work.

DATED: _____

CONTRACTOR

By: _____
Signature

Title: _____

SECTION E

SPECIAL PROVISIONS

The following Special Provisions supplement and amend the latest editions of the Standard Specifications for Public Works Construction (SSPWC “Greenbook”), and the Standard Specification of the State of California Department of Transportation (Caltrans), as noted herein. These Special Provisions have been arranged in a format that parallels the SSPWC “Greenbook” Standard Specifications.

PART 1 - GENERAL PROVISIONS

SECTION 1 - GENERAL, TERMS, DEFINITIONS, ABBREVIATIONS, UNITS OF MEASURE, AND SYMBOLS

1-2 TERMS AND DEFINITIONS. Add or redefine the following:

AGENCY – The City of Lomita, herein referred to as City.

BOARD – The City Council of the City of Lomita, herein referred to as City Council.

ENGINEER –The Public Works Director/City Engineer of the City of Lomita, acting either directly or through properly authorized agents, such agents acting within the scope of the particular duties entrusted to them.

CLAIM -- A separate demand by the Contractor for (A) a time extension, (B) payment of money or damages arising from work done by or on behalf of the Contractor pursuant to the Contract and payment of which is not otherwise expressly provided for or the claimant is not otherwise entitled to, or (C) an amount the payment of which is disputed by the Agency.

1-7 AWARD AND EXECUTION OF THE CONTRACT.

1-7.1 General. Replace the entire sub-section with the following:

Within twenty one (21) calendar days after the date of the City's award of contract, the Contractor shall execute and return all Contract Documents required by the City. The City reserves the right to terminate the award if the above requirement is not met. Such termination will result in the forfeiture of the Proposal Guaranty.

Per Lomita Municipal Code the City of Lomita reserves the right to reject any and all proposals, to waive any informality or irregularity in such bids, and determine the lowest responsible bidder.

The Contract Agreement shall not be considered binding upon the City until executed by the authorized City officials.

1-7.2 Contract Bonds. Add the following

The "Performance Bond" shall remain in effect for one year following the date specified in the Notice of Completion or, if no Notice of Completion is recorded, for one year following the date of final acceptance of the project by the City Council.

SECTION 2 - SCOPE OF THE WORK

2-1 WORK TO BE DONE. Add the following:

Scope of Work. The Work generally consists of furnishing all labor, materials, tools, equipment, and incidentals necessary to construct new water mains on 246th Street, 247th Street, 247th Place, 248th Street, Lomita Boulevard, and Western Avenue as specified in the Specifications and these Special Provisions, and as directed by the Engineer.

The Work also includes all necessary traffic control; preparing and updating construction schedules; posting signs for "NO PARKING" and arranging for towing of cars, if necessary; protecting all utility covers in place; and installing temporary pavement markers.

2-2 PERMITS. Replace the subsection with the following:

The Contractor shall obtain a Business License and Encroachment Permit before commencing construction.

2-5.4 HAUL ROUTES.

Only the designated truck routes shall be used for hauling materials away from the job site or delivering materials to the job site

2-5.4.1 VEHICULAR ACCESS -

When the Contractor begins excavation of a residential driveway, safe access shall be provided within 4 hours and not later than the end of the same workday in which excavation began.

The Contractor shall be responsible to provide at least 48 hour written notice to each affected property before closing or partially closing any driveway or pedestrian access.

At least three (3) days prior to starting work in any location or any street closure, the Contractor shall distribute written notices to all homeowners and residents within 100 feet of the project that will be impacted by the work. The written notices shall be reviewed and approved by City before the Contractor sending them out.

- 1) The Contractor shall provide a minimum 1-inch thick temporary asphalt surface for an access ramp or sidewalk if it is not able to install the permanent improvement within 5 working days following the removal of the existing material at any location. The offset at any transverse or longitudinal joint shall not be more than one-half (1/2) inch. On the temporary asphalt surface: the running slope shall not exceed 1:20; the cross slope shall not exceed 1:50. The Contractor shall not be allowed any additional compensation for the installation and removal of temporary asphalt.

Should any change in these requirements be necessitated by extraordinary occurrences or requirements during the execution of the Work, the Contractor shall obtain prior written approval of the Engineer.

Add the following subsections:

2-5.4.2 TRAFFIC CONTROL PLAN - Traffic control plans have been included in the construction plan set and have been approved by Caltrans and the City of Los Angeles Department of Transportation for traffic control set-ups within their jurisdictions. The Contractor hereby understands and agrees that failure to adhere to, or deviation from, the approved traffic control plans, without prior approval of the Engineer, shall constitute a breach of Contract.

Full compensation for complying with the submittal requirements, furnishing, placing and removing traffic control shall be on a lump sum basis per the Contract Unit Price.

2-5.4.3 TEMPORARY PAVEMENT MARKINGS - Temporary pavement markers/stripping shall be provided by the Contractor prior to leaving the Work site. These temporary markings shall be as follows:

All temporary striping and signs shall be maintained, or replaced as necessary by the Contractor, until permanent striping are restored.

All costs associated with the above requirements shall be included in the Contract Unit Price for Traffic Control.

2-5.4.4 TEMPORARY “NO PARKING” SIGNS - The Contractor is responsible to post "Temporary No Parking" signs at least seventy two (72) hours in advance of the first date of work and the required enforcement. If work is to begin on either a Monday or Tuesday, the Contractor shall post the signs on a Friday. Each sign must include text indicating the beginning and end dates and the hours in effect. "Tow-Away" and "No Parking" must be shown on each sign face. If it is required to temporarily restrict parking 24 hours/day then "Tow-Away" and "No Parking Anytime" must be shown on each sign face. The signs shall be mounted on either 1" x 2" X 3' high wood stakes, Type II barricades, or 39-inch high delineators. Signs shall be spaced at approximately 100' intervals on the effected side(s) of the street. Signs shall not be posted on trees, traffic signal poles, utility poles, street lights, or any other street furniture.

Signs shall be professionally made of moisture-resistant, heavy duty cardboard or other approved material. All signs shall be maintained by the Contractor and kept free of graffiti. Any sign that becomes illegible or is removed shall be replaced within twenty-four (24) hours. The Contractor shall only be permitted to restrict parking for the minimum time necessary to complete on-going work. The Contractor shall be responsible to remove and repost "Temporary No Parking" signs when work will be delayed for more than five (5) consecutive days, or if the work must go beyond the end date shown on the signs, or otherwise directed by the Engineer.

The Contractor shall obtain approval for the signs and the placement thereof from the Engineer. Immediately after this approval and posting, the Contractor shall notify Los Angeles County Sheriff Department – Lomita Station, (310) 539-1661 for review and enforcement. The parking restriction cannot be enforced until the signs have been in place 48 hours and the Police notified.

The Contractor shall maintain said signs through the day of work, and shall remove all of said signs on or within one (1) calendar day of the completion of work within the restricted parking area.

Full compensation for furnishing, placing, maintaining and removing temporary signs shall be considered as included in the Contract Unit Price for Traffic Control
Add the following subsection:

2-5.4.5 TRASH PICK-UP - Trash pick-up days are as follow:
- Wednesdays

The Contractor shall ensure streets affected by the work are accessible to the City's trash trucks.

2-5.4.6 STREET CLOSURES, DETOURS, BARRICADES

In addition to the requirements of this subsection, the Contractor shall conform to the requirements for street closures, detours, and barricades as stipulated in the Special Provisions. However, deviations from the requirements stipulated in the Special Provisions may be

permitted upon written approval of the Public Works Director when such deviations are in the best interest of the City.

Replace the second paragraph with the following:

The Contractor shall notify the Public Works Department at (310) 325-7110, at least ten (10) working days in advance of closing or partially closing any street and comply with their requirements. In addition, the Contractor shall notify the Los Angeles County Sheriffs Department, (310) 539 -1661 and Los Angeles County Fire Department at (310) 326-2461 at least two (2) working days in advance of such closing.

Add the following:

The Contractor shall install, maintain, and remove all temporary delineators, barricades, lights, warning signs and other devices necessary to control traffic as specified in the project plans, traffic control plans and these specifications. Materials for a temporary facility may be provided from new or used materials. If used materials are provided, they shall be sound, in good condition and otherwise meet the requirements of new materials. All traffic control devices shall be free of graffiti, and the Contractor shall be responsible to immediately clean and/or replace any device to the satisfaction of the Engineer.

Full compensation for furnishing, installing, maintaining and removing the above traffic control devices shall be considered as included in the Contract Unit Price for Traffic Control.

Where streets in which improvements are being constructed are specified hereinafter to be closed to through traffic, it shall be understood that such closures shall apply only to the portions of such streets where construction is actually in progress.

After award of the contract, the Contractor shall submit to the City its proposed schedule for closure based on the Traffic Control Plan and comply with the requirements specified herein. This submittal shall be made sufficiently in advance (street closure schedules MUST be submitted ten (10) days prior to closing the affected street) of any rerouting or diversion of traffic by the Contractor to allow for a review of the Contractor's proposed traffic control by the Public Works Director.

2-5.4.7 PROJECT CONSTRUCTION SIGNS AND PORTABLE CHANGEABLE MESSAGE

SIGNS - The Contractor shall furnish and install signs at locations to be determined by the Engineer. The signs shall be in accordance with City of Lomita Standard Plan No. T503.

The Contractor shall furnish and install two (2) Portable Changeable Message signs (PCMS) on the construction site for use during construction of the project and including two weeks prior to the start of construction. Each PCMS shall be manufactured by Solar Tech and be model MB2 (contact BC Rentals at (714) 279-6868 for information). The Contractor shall install a locking device on each PCMS to prohibit access to the computer keyboard. The Contractor shall provide to the Engineer the key or combination to each locking device and the computer password to each PCMS **OR** possess any equipment, on any working day, to enter or modify a message for each PCMS as directed by the Engineer. Contractor shall relocate each PCMS as directed by Engineer at no additional cost to the City.

Full compensation for furnishing, installing, maintaining and removing signs shall be on a lump sum basis as part of the Traffic Control Bid Item.

2-8 EXTRA WORK

Add the following:

Payment for additional work and all expenditures in excess of the Contract Price must be authorized in writing by the Engineer. Such authorization shall be obtained by the Contractor prior to engaging in additional work. It shall be the Contractor's sole responsibility to obtain written approval from the Engineer for any change(s) in material or in the work proposed by suppliers or subcontractors. No payment shall be made to the Contractor for additional work which has not been approved in writing, and the Contractor hereby agrees that it shall have no right to additional compensation for any work not so authorized.

The Contractor shall be responsible to provide all data and to obtain all approvals required by the Specifications, including submittal of Daily Extra Work Reports. Disputed work claims shall comply with 2-8 as modified herein.

SECTION 3 – CONTROL OF THE WORK

3-7 CONTRACT DOCUMENTS.

3-7.1 General. Add the following sentence to the first paragraph to read as follows:

The Contractor shall maintain a control set of Plans and Specifications on the Work site at all times. All final locations determined in the field, and any deviations from the Plans and Specifications, shall be marked in red on this control set to show as-built conditions. Upon completion of the Work, the Contractor shall submit the control set to the Engineer for approval. Final payment will not be made until this requirement is met.

Add the following subsections:

3-7.1.1 Plans. Included as part of the Contract Documents are the following, which show the location, character, dimensions or details of the Work:

1) Project Plans

The plans and data provided with the Contract Documents are based on existing plans and documents. The plans and data are provided for information only. The Owner does not guarantee their accuracy and correctness. If the Bidder in preparing the Bid Proposal uses this information, the Bidder assumes all risks resulting from conditions differing from the information shown. The Bidder, in consideration for the information being provided, hereby releases the City, from any responsibility of obligation as to the accuracy of such information or for any additional compensation for work performed due to assumptions based on the use of such information.

2) Standard Plans

- a. City of Lomita Standard Plans, latest edition
- b. Standard Plans for Public Works Construction, latest edition, promulgated by Public Works Standards, Inc.
- c. Standard Plans of the State of California Department of Transportation (Caltrans), latest edition
- d. City of Los Angeles Standard Plans, latest edition

3-7.1.2 SPECIFICATIONS. The Work shall be performed or executed in accordance with these Provisions and the following:

- 1) Standard Specifications for Public Works Construction, latest edition and supplements thereto, hereinafter referred to as the Greenbook, as written and promulgated by Public Works Standards, Inc. The Greenbook is published by BNi Building News, Inc., 1612 South Clementine Street, Anaheim, CA 92802, Phone: (800) 873-6397.
- 2) Sections 56-2, 84, 85, 86 and 90-10 of the State of California Department of Transportation (Caltrans) Standard Specifications, latest edition.

3-7.2 Precedence of the Contract Documents. Replace the entire subsection with the following:

If there is a conflict between any of the Contract Documents, the document highest in precedence shall control. The order of precedence shall be as follows:

- 1) Permits issued by other agencies.
- 2) Change Orders (including Plans and Specifications attached thereto).
- 3) Public Works Agreement
- 4) Addenda
- 5) Special and General Provisions
- 6) Plans
- 7) City Standard Plans
- 8) Other Standard Plans
- 9) Greenbook
- 10) Reference Specifications

With reference to the Plans/Drawings, the order of precedence is as follows:

- 1) Change Order plans govern over Addenda and Contract plans
- 2) Addenda plans govern over Contract plans
- 3) Contract plans govern over standard plans
- 4) Detail plans govern over general plans
- 5) Figures govern over scaled dimensions

Within the Specifications, the order of precedence is as follows:

- 1) Change Orders
- 2) Permits from other agencies/Supplemental Agreements
- 3) Special Provisions
- 4) Instruction to Bidders
- 5) Referenced Standard Plans
- 6) Referenced Standard Specifications

If the Contractor, in the course of the Work, becomes aware of any claimed errors or omissions in the Contract Documents or in the City's fieldwork, the Contractor shall immediately inform the Engineer. The Engineer shall promptly review the matter, and if the Engineer finds an error or omission has been made the Engineer shall determine the corrective actions and advise the Contractor accordingly. If the corrective work associated with an error or omission increases or decreases the amount of work called for in the Contract, the City shall issue an appropriate Change Order in accordance with subsection 2-8. After discovery of an error or omission by the Contractor, any related work performed by the Contractor shall be done at the Contractor's risk

unless authorized by the Engineer.

3-8 SUBMITTALS.

Submittals are required for the following:

- Construction Schedule
- Traffic Control Plan (TCP) prepared by a registered Civil or Traffic Engineer
- Water Pollution Control Plan
- Asphalt Concrete Mix Designs (Level Course and AC overlay)
- Concrete Mix Designs
- Base Material Mix Design
- Striping and Marking Materials

All Contractor submittals shall be carefully reviewed against the contract documents by an authorized representative of the Contractor, prior to submittal to the Engineer. A letter shall be included with each submittal stating the contract documents have been reviewed and the submitted product is correct for the project application and in strict conformance with the contract documents. The letter affidavit must be dated and signed by both the Contractor and the product manufacturer or service provider. In the case of shop drawings, each sheet shall be so dated and signed for approval. No consideration for review by the Engineer of any Contractor submittals will be made for any items which are not accompanied by affidavit by the Contractor. All submittals without an affidavit will be returned to the Contractor without action taken by the Engineer, and any delays caused thereby shall be the total responsibility of the Contractor.

The Engineer's review of Contractor submittals shall not relieve the Contractor of the entire responsibility for the correctness of details and dimensions. The Contractor shall assume all responsibility and risk for any misfits due to any errors in Contractor submittals. The Contractor shall be responsible for the dimensions and the design of adequate connections and details.

3-12 WORK SITE MAINTENANCE.

3-12.1 GENERAL. Add the following:

3-12.1 Temporary Light, Power, and Water. The Contractor shall obtain a construction water meter from the City. An \$800 deposit is required and refundable upon return of the meter in good working condition. The Contractor shall pay for the water used, at the City's current water rates.

3-12.1.2 Graffiti Removal. The Contractor shall maintain the Work, all of its equipment, and all traffic control devices, including signage, free of graffiti throughout the duration of the Contract. The Contractor shall respond to any request from the Engineer to remove graffiti within 4 hours of notification. Should the Contractor fail to respond to such request, the City reserves the right to make other arrangements for the requested graffiti removal and deduct the cost from any monies due the Contractor.

3-12.4 STORAGE OF EQUIPMENT AND MATERIALS.

3-12.4.2 STORAGE IN PUBLIC STREETS. Add the following:

Contractor's Storage Yard. The Contractor shall be responsible for obtaining a storage yard for the duration of the Work. If the proposed location of the yard is located within the boundaries of the City, the Contractor shall obtain prior approval from the Engineer. Contractor's equipment will not be allowed to park overnight on any City street.

3-13 COMPLETION, ACCEPTANCE AND WARRANTY. Add the following:

It is the intent of the Specifications that only first-class materials and workmanship will be acceptable. The Contractor shall take all necessary measures to protect Work from damage and prevent accidents and vandalism during any and all phases of the work.

Until the final acceptance of the Work by the City, by written action of the Engineer, the Contractor shall have the charge and care thereof and will bear the risk of injury or damage to any part of the Work by the action of the elements, vandalism, or any other cause. The Contractor shall rebuild, repair, restore and make good all injuries or damages to any portion of the Work occasioned by any cause before its completion and acceptance and will bear the expense thereof.

If, in the Engineer's judgment, the Work has been completed and is ready for acceptance, the Engineer will so certify and will determine the date when the Work was completed. This will be the date when the Contractor is relieved from responsibility to protect the Work. The Engineer may cause a Notice of Completion to be filed and recorded with the Los Angeles County Recorder's Office. At the Engineer's option, the Engineer may certify acceptance to the City Council who may then cause a Notice of Completion to be filed and recorded with the Los Angeles County Recorder's Office.

Add the following subsection:

3-13.4 Manufacturer's Warranties. Manufacturer's warranties shall not relieve the Contractor of liability under these Specifications. Such warranties only shall supplement the Contractor's responsibility.

SECTION 4 - CONTROL OF MATERIALS

4-1 GENERAL- Add the following paragraph after the second paragraph:

The Contractor and all subcontractors, suppliers, and vendors, shall guarantee that the entire Work will meet all requirements of this contract as to the quality of materials, equipment, and workmanship.

The Contractor, at no cost to the City, shall make any repairs or replacements made necessary by defects in materials, equipment, or workmanship that become evident within one year after the date of recordation of the Notice of Completion.

Within this one year period, the Contractor shall also restore to full compliance with requirements of this contract any portion of the Work which is found to not meet those requirements. The Contractor shall hold the City harmless from claims of any kind arising from damages due to said defects or noncompliance.

Security of this guarantee shall be in the form of a Maintenance Bond furnished to the City by the Contractor. There shall be specific wording in the Maintenance Bond, that includes the

guarantee or warranty of the labor and materials for a one year period, commencing from the recording date of the Notice of Completion by the County Recorder. The guaranteed amount shall be for 100 percent of the total amount earned to date as indicated on the final progress payment. The City reserves the right to withhold the retention until the Maintenance Bond has been accepted by the City.

The Contractor shall make all repairs, replacements, and restorations covered by the Maintenance Bond within 10 working days after the date of the Engineer's written notice. Failure to comply with such notice, will cause the City to file claim against the bond.

Excepted from the Maintenance Bond will be defects caused by acts of God, acts of the City, acts of vandals, or by acts of others outside or beyond the control of the Contractor.

If the work, or any portion thereof, shall be damaged in any way, or if any defective materials or faulty workmanship shall be discovered at any time prior to the final payment, the Contractor shall forthwith, at its own cost and expense, repair said damage, or replace such defective materials, or remedy such faulty workmanship in a manner satisfactory to the Engineer.

4-2 PROTECTION. Add the following:

The Contractor shall assume all risks and expense of interference and delay in his operations, and the protection from or the repair of damage to improvements being built under the contract, as may be caused by water of whatever quantity from floods, storms, industrial waste, irrigation, underground or other sources. However, the Contractor shall be entitled to an extension of time in accordance with the provisions of Subsection 6-4. The Contractor shall also assume full responsibility and expense of protecting, or removing and returning to the site of Work, all equipment or materials under his care endangered by any action of the elements.

Furthermore, the Contractor shall indemnify and hold the City harmless from all claims or suits for damages arising from his operations in dewatering the Work and control of water.

SECTION 5 – LEGAL RELATIONS AND RESPONSIBILITIES

5-7 SAFETY. Add the following:

5-7.2.4 PUBLIC SAFETY DURING NON-WORKING HOURS

Notwithstanding the Contractor's primary responsibility for safety on the job site when the Contractor is not present, the Engineer at Engineer's option after attempting to contact the Contractor may direct City Forces to perform any functions Engineer may deem necessary to ensure public safety at or in the vicinity of the job site. If such procedure is implemented, the Contractor will bear all expenses incurred by the City.

In all cases the judgment of the Engineer shall be final in determining whether or not an unsafe situation exists.

5-7.2.5 WRITTEN COMMUNICATIONS

Contractor's written communications, including letters, field memoranda, requests for substitution (RFS) and requests for information (RFI) shall be written in a clear and concise manner. In particular, RFSs and RFIs shall clearly describe the condition or issue of concern, the cause of the condition or issue and the proposed solution or specific question being posed

to the Engineer. Contractor shall not be entitled to any delays or additional compensation as a result of issues that in the Engineer's opinion originated with, or were exacerbated by, poor written communications by the Contractor.

SECTION 6 – PROSECUTION AND PROGRESS OF THE WORK

6-1 CONSTRUCTION SCHEDULE AND COMMENCEMENT OF WORK. Replace the entire subsection with the following:

6-1.1 General. Within ten (10) working days after the date of the City's execution of the Contract, the Contractor shall submit a proposed construction schedule to the Engineer for approval. The schedule shall be in accordance with the Specification and these Special Provisions.

Prior to issuing the Notice to Proceed, the Engineer will schedule a Pre-Construction Meeting with the Contractor to review the proposed construction schedule and delivery dates, arrange utility coordination and clarify inspection procedures.

Notwithstanding any other provisions of the Contract, the Contractor shall not be obligated to perform any work and the City will not be obligated to accept or pay for any work performed by the Contractor prior to delivery of a Notice to Proceed. The City's knowledge of work being performed prior to delivery of the Notice to Proceed shall not obligate the City to accept or pay for such work. The Contractor shall provide all required Contract bonds and evidences of insurance prior to commencing work.

6-1.2 Criteria. Construction schedules shall consider the following:

1- TRASH COLLECTION. Trash pick-up days are as follow:
- Wednesdays

2- TEMPORARY PAVEMENT MARKINGS; CAT-TRACKING AND STRIPING:
Reflective yellow and white "Tabs" MUST be installed following the installation of asphalt to indicate locations of lane lines, STOP limit lines, and all yellow crosswalks and shall be maintained until new striping is installed. Cat-tracking layout for final pavement markings shall be completed at least 48 hours prior to scheduled placement and the Engineer shall approve cat-tracking prior to final placement. Striping shall take place a minimum of seven (7) days after paving.

3- WORK HOURS. Work shall be performed between the hours of 7:00 A.M. and 4:00 P.M. unless otherwise approved by the Engineer. The Contractor will be allowed to work on Fridays when City Hall is scheduled to be closed. No work shall occur on Sundays or holidays. The following days are holidays: Memorial Day May 29, 2023, Independence Day, July 4, 2023; Labor Day, September 4, 2023; Veteran's Day, November 10, 2023; Thanksgiving, November 23 and 24, 2023.

6-1.3 Compensation. Compensation for all scheduling activities will be made on the lump sum basis per the Contract Unit Price for "MOBILIZATION AND DEMOBILIZATION," in the Bidder's Proposal.

6-10 SEQUENCE OF CONSTRUCTION

6-10.1 Multiple Headings. In order to meet the contract schedule, the Contractor will be allowed to initiate and maintain two or more construction headings. However, the Contractor will not be allowed to have multiple phases of work occurring that have the corresponding traffic control devices in conflict with each other.

SECTION 7 - MEASUREMENT AND PAYMENT

7-2 LUMP SUM WORK

Add the following:

Contractor shall submit a detailed schedule of value for all lump sum bid items to the Engineer within 15 days after award of contract.

7-3 PAYMENT

7-3.1 General

Revise paragraph one to read: The unit and lump sum bid prices for each item of work shown on the proposal shall include full compensation for furnishing the labor, materials, tools, and equipment and doing all the work, including restoring all existing improvements, to complete the item of work in place and no other compensation will be allowed thereafter. Payment for incidental items of work not separately listed shall be included in the prices shown for the other related items of work. The following items of work pertain to the bid items included within the Proposal:

Item No.1 Mobilization and Demobilization: Work under this item shall include the cost to secure bonds and insurance, movement of personnel, equipment, materials and incidentals to and from the project sites, securing a temporary construction yard, maintaining the project in a safe, clean and orderly manner during construction and final cleanup of the work and staging sites.

Included in this item are any costs associated with construction activities including construction survey required to conform to the notes on the construction plans.

Payment for “**Mobilization and Demobilization**” shall be made at the lump sum price indicated in the Bid Sheets and progress payments shall be made upon the judgment of the Engineer as percent complete.

Item No.2 Traffic Control: It shall be the Contractor’s responsibility to prepare and provide final Traffic Control throughout the construction period. Final traffic control implementation shall be provided under the supervision of the Contractor with the concurrence of the Engineer.

The final TCP implementation by the Contractor shall conform to the requirements of the latest editions of California MUTCD, the WATCH Manual, and these Special Provisions and as approved by the Engineer. The full and normal responsibility for TCP implementation is the Contractor’s responsibility as if no plans are or were provided by the City.

An adequate number of flag persons shall be stationed at construction locations where traffic control is required including intersections of streets, wherever it is necessary to temporarily stop or detour traffic for the construction or the movement of materials and equipment. During the construction activity hours flaggers and workers shall wear bright orange vests and hardhats while working in or around the construction area. Traffic stoppages shall be limited to time periods approved by the Engineer. No intersection shall be closed longer than 30 minutes without the approval of the Engineer. The TCP is considered to include trained flaggers used at both major and minor street intersections and or as recommended or required by the project inspector or Engineer without any additional compensation to the Contract.

It is anticipated that, from time to time, changes to the approved TCP may be needed due to unanticipated field conditions. The Contractor, if so directed by the Inspector or Engineer, shall make adjustments to address any deficiency identified by City forces at no additional cost to the City.

Pedestrian and bicycle traffic must be provided for and maintained in a safe manner throughout the construction period. Pedestrian and emergency vehicular access shall be maintained to all residences, businesses and manufacturing establishments within the construction area.

Signs, lights, flags, flag persons, and other warning and safety devices shall conform to the requirements set forth in the current editions of the WATCH Manual and California MUTCD. If attention is directed to the existence of a hazard and Contractor fails to provide remediation, or, such devices as may be needed, said devices may be placed by the City. The cost of said placement by the City, as for all TRAFFIC CONTROL, shall be the sole responsibility of the Contractor; said costs, if any, shall be deducted from the progress payment and from the total contract price for the work.

The contractor shall notify the occupants of all affected properties at least forty-eight (48) hours prior to any temporary obstruction of access. Vehicular access to property line shall be maintained, except as required for construction for a reasonable period of time. No overnight closure of any driveway will be allowed, except as permitted by the Engineer.

At least one twelve foot (12') wide traffic lane shall be provided for each direction of travel on all streets at all times. The traffic lanes shall be maintained on pavement, and shall remain unobstructed.

Clearances from traffic lanes shall be five (5) feet to the edge of any excavation and two (2) feet to the face of any curb, pole, barricade, delineator, or other vertical obstruction, unless approved by the Engineer in writing in advance of such work.

Detouring is discouraged but will be considered for usage by the City. If approved, any detouring shall be accomplished by use of traffic signs, barricades, flag persons, etc. conforming to the requirements of the WATCH or California MUTCD, and the Engineer.

Payment for "**Traffic Control**" shall be made at the lump sum price indicated in the Bid Sheet. The contract lump sum price for "Traffic Control" shall include full compensation for furnishing all labor, materials, tools, equipment and incidentals and for doing all the traffic control related work involving placing, removing, storing, maintaining, moving to new locations, replacing and disposing of the components of traffic control system as specified in the State Standard Specifications, SSPWC, and these Special Provisions, and as directed by the Engineer. The

lump sum price shall also include steel plates and temporary AC including installation and removal, all associated temporary signing and striping, flashing arrow signs, PCMS signs, and flagging and/or flagger costs and no additional compensation will be made therefor.

Item No.3 Excavation Safety Measures: Excavation Safety Measure shall conform to Section 5-7 Safety of SSPWC.

Work under this item shall include, but not be limited to, all labor, tools, equipment and material costs of providing a safe work site for public and workers as required to complete the work in place including shoring and all necessary trench safety measures required by OSHA.

Payment for “**Excavation Safety Measures**” shall be made at the lump sum price as indicated in the Bid Sheets.

Item No.4 Construction Surveying: Construction staking and monumentation shall conform to Section 3-10 Surveying of SSPWC.

Work under this item shall include, but not be limited to, all labor, tools, equipment and material costs of surveying, establishing horizontal and vertical controls, providing construction staking, establishing centerline ties, adjusting survey monuments, filing pre- and post-construction corner records with the County, and other survey items as required to complete the work in place.

Payment for “**Construction Surveying**” shall be made at the lump sum price indicated in the Bid Sheets.

Item No.5 Water Pollution Control (Includes BMP Installation and Maintenance): The contract unit price shall include, but not be limited to, all labor, tools, equipment and material costs for installing and maintaining BMPs for water pollution control.

Payment for “**Water Pollution Control (Includes BMP installation and Maintenance)**” shall be made at the lump sum price as indicated in the Bid Sheets.

Item No.6 Re-establish Survey Monuments: Re-establish Survey Monuments shall conform to Section 3-10 Surveying and Section 400-2 Permanent Survey Markers of SSPWC.

Section 400-3 Payment shall be replaced with the following:

No separate or additional payment will be made for 1) protection of existing improvements, and 2) restoration of existing improvements. Permanent survey marker will be restored by the contractor as its own expense and have no cost to the City.

Work under this item shall include, but not be limited to, all labor, tools, equipment and material costs of surveying, adjusting survey monuments, filing pre- and post-construction corner records with the County, re-establishing property corners disturbed by the work, preparing record of survey, protecting and restoring existing monuments and other survey items as required to complete the work in place.

Payment for “**Re-establish Survey Monuments**” shall be made at the lump sum price as indicated in the Bid Sheets.

Item No.7 Sawcutting: Work under this item shall include, but not be limited to, all labor, tools, equipment and material costs for sawcutting AC pavement, and all other work items as required to complete the work in place.

Payment for “**Sawcutting**” shall be made at the lump sum price as indicated in the Bid Sheets.

Item No. 8 Construct New 8” PVC C900 DR 18 Water Main, Including But Not Limited To Furnishing Of Fittings And End Caps. Construction Shall Be Per City Of Lomita Standards And Include Trenching, Bedding and Backfill: Work under this item shall include, but not be limited to, all labor, tools, equipment and material costs for trenching, installing new water main and fittings, placing bedding, and backfilling trenches, and all other work items as required to complete the work in place.

Payment for “**Construct New 8” PVC C900 DR 18 Water Main, Including But Not Limited To Furnishing Of Fittings And End Caps. Construction Shall Be Per City Of Lomita Standards And Include Trenching, Bedding and Backfill**” shall be made on a per linear foot unit price basis as indicated in the Bid Sheets.

Item No. 9 Construct New 8” PVC C900 DR 14 Water Main, Including But Not Limited To Furnishing Of Fittings And End Caps. Construction Shall Be Per City Of Lomita Standards And Include Trenching, Bedding and Backfill: Work under this item shall include, but not be limited to, all labor, tools, equipment and material costs for trenching, installing new water main and fittings, placing bedding, and backfilling trenches, and all other work items as required to complete the work in place.

Payment for “**Construct New 8” PVC C900 DR 14 Water Main, Including But Not Limited To Furnishing Of Fittings And End Caps. Construction Shall Be Per City Of Lomita Standards And Include Trenching, Bedding and Backfill**” shall be made on a per linear foot unit price basis as indicated in the Bid Sheets.

Item No. 10 Provide and Install 8” Gate Valve: Work under this item shall include, but not be limited to, all labor, tools, equipment and material costs for removing the existing monitoring well box and cover, temporarily lowering and/or covering the well to facilitate paving operation, reinstalling existing monitoring well box and cover to grade, restoring all existing improvements damaged by the work, and all other work items as required to complete the work in place.

Payment for “**Provide and Install 8” Gate Valve**” shall be made on a per each unit price basis as indicated in the Bid Sheets.

Item No. 11 Furnish and Install 1” Water Service, Connect to Existing Meter and Box: Work under this item shall include, but not be limited to, all labor, tools, equipment and material costs for removing the existing monitoring well box and cover, temporarily lowering and/or covering the well to facilitate paving operation, reinstalling existing monitoring well box and cover to grade, restoring all existing improvements damaged by the work, and all other work items as required to complete the work in place.

Payment for “**Furnish and Install 1” Water Service, Connect to Existing Meter and Box**” shall be made on a per each unit price basis as indicated in the Bid Sheets.

Item No. 12 Cut Existing Water Line and Remove Interfering Portions. Plug with Concrete and Abandon: Work under this item shall include, but not be limited to, all labor, tools, equipment and material costs for removing the existing monitoring well box and cover, temporarily lowering and/or covering the well to facilitate paving operation, reinstalling existing monitoring well box and cover to grade, restoring all existing improvements damaged by the work, and all other work items as required to complete the work in place.

Payment for “**Cut Existing Water Line and Remove Interfering Portions. Plug with Concrete and Abandon**” shall be made on a per each unit price basis as indicated in the Bid Sheets.

Item No. 13 Connect to Existing Water Main (Includes Installation of Transition Coupling, if Required Per Plans): Work under this item shall include, but not be limited to, all labor, tools, equipment and material costs for removing the existing monitoring well box and cover, temporarily lowering and/or covering the well to facilitate paving operation, reinstalling existing monitoring well box and cover to grade, restoring all existing improvements damaged by the work, and all other work items as required to complete the work in place.

Payment for “**Connect to Existing Water Main (Includes Installation of Transition Coupling, if Required Per Plans)**” shall be made on a per each unit price basis as indicated in the Bid Sheets.

Item No.14 Construct AC Pavement Base Course Including Subgrade and Base Preparation Per City of Lomita Trench Detail: Work under this item shall include, but not be limited to, all labor, tools, equipment and material costs for applying a tack coat, placing, spreading and compacting the variable depth asphalt concrete leveling course and all other work items as required to complete the work in place.

Payment for “**Construct AC Pavement Base Course Including Subgrade and Base Preparation Per City of Lomita Trench Detail**” shall be made on a per ton unit price basis as indicated in the Bid Sheets.

Item No.15 Cold Plane Asphalt Concrete (2”) Depth Per City of Lomita Trench Detail”: Work under this item shall include, but not be limited to, all labor, tools, equipment and material costs for cold milling the asphalt concrete pavement, providing additional motorized street sweepers per Section 3-12.1, removal and disposal of pavement fabric if encountered, constructing temporary asphalt concrete ramps along milled edges, hauling and disposing the milled material offsite, and all other work items as required to complete the work in place.

Cold mill operation shall conform to Section 404 and all applicable sections of the SSPWC and shall consist of all excavation required and directed by the Engineer.

Payment for “**Cold Plane Asphalt Concrete (2”) Depth Per City of Lomita Trench Detail**” shall be at the unit price bid per square foot. The contract unit price shall include full compensation for furnishing all labor, materials, tools, equipment, and incidentals, and for doing all work involved in “Cold Mill Existing Pavement 2” including disposing of material removed and no additional compensation will be allowed therefor.

Item No.16 Construct AC Pavement Cap Per City of Lomita Standards: Work under this item shall include, but not be limited to, all labor, tools, equipment and material costs for

applying a tack coat, spreading and compacting the asphalt concrete finish course and all other work items as required to complete the work in place.

Payment for “**Construct AC Pavement Cap Per City of Lomita Standards**” shall be made on a per ton unit price basis as indicated in the Bid Sheets.

Item No.17 Construct AC Pavement Base Course Including Subgrade and Base Preparation Per City of Los Angeles Trench Detail: Work under this item shall include, but not be limited to, all labor, tools, equipment and material costs for applying a tack coat, placing, spreading and compacting the variable depth asphalt concrete leveling course and all other work items as required to complete the work in place.

Payment for “**Construct AC Pavement Base Course Including Subgrade and Base Preparation Per City of Los Angeles Trench Detail**” shall be made on a per ton unit price basis as indicated in the Bid Sheets.

Item No.18 Cold Plane Asphalt Concrete (2”) Depth Per City of Los Angeles Trench Detail”: Work under this item shall include, but not be limited to, all labor, tools, equipment and material costs for cold milling the asphalt concrete pavement, providing additional motorized street sweepers per Section 3-12.1, removal and disposal of pavement fabric if encountered, constructing temporary asphalt concrete ramps along milled edges, hauling and disposing the milled material offsite, and all other work items as required to complete the work in place.

Cold mill operation shall conform to Section 404 and all applicable sections of the SSPWC and shall consist of all excavation required and directed by the Engineer.

Payment for “**Cold Plane Asphalt Concrete (2”) Depth Per City of Los Angeles Trench Detail**” shall be at the unit price bid per square foot. The contract unit price shall include full compensation for furnishing all labor, materials, tools, equipment, and incidentals, and for doing all work involved in “Cold Mill Existing Pavement 2” including disposing of material removed and no additional compensation will be allowed therefor.

Item No.19 Construct AC Pavement Cap Per City of Los Angeles Standards: Work under this item shall include, but not be limited to, all labor, tools, equipment and material costs for applying a tack coat, spreading and compacting the asphalt concrete finish course and all other work items as required to complete the work in place.

Payment for “**Construct AC Pavement Cap Per City of Lomita Standards**” shall be made on a per ton unit price basis as indicated in the Bid Sheets.

Item No.20 Construct AC Pavement Base Course Including Subgrade and Base Preparation Per Caltrans Trench Detail: Work under this item shall include, but not be limited to, all labor, tools, equipment and material costs for applying a tack coat, placing, spreading and compacting the variable depth asphalt concrete leveling course and all other work items as required to complete the work in place.

Payment for “**Construct AC Pavement Base Course Including Subgrade and Base Preparation Per Caltrans Trench Detail**” shall be made on a per ton unit price basis as indicated in the Bid Sheets.

Item No.21 Cold Plane Asphalt Concrete (2") Depth Per Caltrans Trench Detail": Work under this item shall include, but not be limited to, all labor, tools, equipment and material costs for cold milling the asphalt concrete pavement, providing additional motorized street sweepers per Section 3-12.1, removal and disposal of pavement fabric if encountered, constructing temporary asphalt concrete ramps along milled edges, hauling and disposing the milled material offsite, and all other work items as required to complete the work in place.

Cold mill operation shall conform to Section 404 and all applicable sections of the SSPWC and shall consist of all excavation required and directed by the Engineer.

Payment for "**Cold Plane Asphalt Concrete (2") Depth Per Caltrans Trench Detail**" shall be at the unit price bid per square foot. The contract unit price shall include full compensation for furnishing all labor, materials, tools, equipment, and incidentals, and for doing all work involved in "Cold Mill Existing Pavement 2" including disposing of material removed and no additional compensation will be allowed therefor.

Item No.22 Construct AC Pavement Cap Per Caltrans Standards: Work under this item shall include, but not be limited to, all labor, tools, equipment and material costs for applying a tack coat, spreading and compacting the asphalt concrete finish course and all other work items as required to complete the work in place.

Payment for "**Construct AC Pavement Cap Per Caltrans Standards**" shall be made on a per ton unit price basis as indicated in the Bid Sheets.

Item No.23 Construct PCC Bus Pad Including Dowel Installation, Subgrade and Base Preparation Per Caltrans Standards: Work under this item shall include, but not be limited to, all labor, tools, equipment and material costs for grading and compacting subgrade, constructing concrete bus pad per Section 201 and 302-6 of the SSPWC, installing expansion joint material, constructing weakened plane joints, restoring all existing improvements damaged by the work, and all other work items as required to complete the work in place.

Payment for "Construct PCC Bus Pad Including Dowel Installation, Subgrade and Base Preparation Per Caltrans Standards" shall be made on a square foot unit price basis as indicated in the Bid Sheets.

Item No.24 Replace Damaged Pavement Striping, Markings, Reflectors, and Legends: Traffic striping, legend, and pavement markers within the area of work shall be installed in accordance with the improvement plan, the State Standard Specifications, Sections 84 and 85, Revised Standard Plans A20A to A20E, and Standard Plans A24A to A24F and Sections 214 and 314 of SSPWC.

Traffic striping, stop limit/crosswalk lines, and legend shall be thermoplastic unless otherwise called for on the plans. All pavement markers shall be adhered with "epoxy"; Bituminous adhesive will not be accepted.

Blue raised retro-reflective bidirectional pavement marker shall be installed 6 inches off the street centerline at each fire hydrant, on the fire hydrant side of the roadway per California MUTCD section 3B.11 and figure 3B-102 (CA). Installation of Blue Reflectorized Pavement Markers including Pavement Markers across fire hydrants shall be considered as included in the lump sum for this item of work.

Payment for “Furnish and Install Striping, Markings, Reflectors, Raised Pavement Markers” detailed on the plans shall be on a lump sum price basis and shall be considered full compensation for furnishing labor, materials, equipment, and disposal to complete the construction, including installing traffic striping, pavement legends, markings, markers and blue raised markers for fire hydrant all in place as shown on plans and no additional compensation will be allowed therefor.

Item No.25 Soil Sampling if hazardous Soil is Encountered (As Needed Only): Work under this item shall include, but not be limited to, all labor, tools, equipment and material costs for coring into the existing asphalt, taking soil samples, sample analysis, preparation of an analysis report, and all other work items as required to complete the work in place.

Soil sampling and testing shall be done by a qualified environmental consultant. Contractor shall prepare a soil sampling plan only after possible hazardous soil is found. Soil samples will only need to be collected if the soil excavated has apparent soil contamination or odor. If possible soil contamination is encountered then the Contractor shall analyze for the following constituents:

- Total Petroleum Hydrocarbons GRO/DRO/ORO (EPA Method 8015B)
- Volatile Organic Compounds (EPA Method 5035/8260B)
- Cam 17 Metals (6010B/7196A/7471A)
- WET STLC (EPA Method 6010B)

Payment for “**Soil Sampling if Hazardous Soil is Encountered (As Needed Only)**” shall be at the unit price bid per each. The contract unit price shall include full compensation for furnishing all labor, materials, tools, equipment, lab testing, and incidentals, and for doing all work involved in “Soil Sampling if Hazardous Soil is Encountered (As Needed)” including disposing of material removed and no additional compensation will be allowed therefor.

Item No.26 Excavation, Haul Away and Disposal of Hazardous Soil if Encountered (As Needed): Work under this item shall include, but not be limited to, all labor, tools, equipment and material costs for sawcutting, excavation, haul away, disposal, special handling requirements, hazardous dump fees, and all other work items as required to complete the work in place.

Payment for “**Excavation, Haul Away and Disposal of Hazardous Soil if Encountered (As Needed)**” shall be at the unit price bid per ton. The contract unit price shall include full compensation for furnishing all labor, materials, tools, equipment, and incidentals, and for doing all work involved in “Excavation, Haul Away and Disposal of Hazardous Soil if Encountered (As Needed)” including disposing of material removed and no additional compensation will be allowed therefor.

7-4.3 MARKUP. Replace the entire subsection with the following:

The markups mentioned hereinafter shall include, but are not limited to, all costs for the services of superintendents, project managers, timekeepers and other personnel not working directly on the change order, and pickup or yard trucks used by the above personnel. These costs shall not

be reported as labor or equipment elsewhere except when actually performing work directly on the change order and then shall only be reported at the labor classification of the work performed.

(a) **Work by Contractor.** The following percentages shall be added to the Contractor's costs and shall constitute the mark-up for all overhead and profit, which shall be deemed to include all items of expense not specifically designated as cost or equipment rental in Subsections 3-7-4.2.1, 7-4.2.2, and 7-4.2.3.

Labor	20
Materials	15
Equipment Rental	15
Other Expenditures	15

To the sum of the costs and markups provided for in this subsection, one (1) percent shall be added as compensation for bonding.

(b) **Work by Subcontractor.** When any part of the extra work is performed by a subcontractor, the markup established in 7-4.2.1 shall be applied to the subcontractor's actual cost of such work. A markup of ten (10) percent on the first \$5,000 of the subcontracted portion of the extra work and a mark-up of 5 percent on work added in excess of \$5,000 of the subcontracted portion of the extra work may be added by the Contractor.

The markups specified in parts (a) and (b) above shall be considered as including, but not limited to, the Contractor's labor costs for personnel not working directly on the extra work, including the cost of any tools and equipment that they may use. Such costs shall not be reported as labor or equipment costs elsewhere except when they are actually used in the performance of the extra work. Labor costs shall in that case be reported for the labor classification corresponding to the type and nature of extra work performed.

PART 2 - CONSTRUCTION MATERIALS

SECTION 200 - ROCK MATERIALS

200-2 UNTREATED BASE MATERIALS

200-2.1 General. Replace the entire subsection with the following:

Untreated base for pavement, curb, gutter, cross gutters, bus pads, hardscape and other improvements shall be Crushed Aggregate Base conforming to 200-2.2.

201-1 PORTLAND CEMENT CONCRETE

The Portland cement concrete pavement class shall be: 520-A-2500.

SECTION 203 - BITUMINOUS MATERIALS

203-5.4 EMULSION - AGGREGATE SLURRY (EAS)

203-5.4.1 General. Replace the first sentence with the following:

Emulsion-aggregate slurry shall be a stable mixture of emulsified asphalt, mineral aggregate, water and retardant and is herein referred to as slurry.

203-5.4.2 Materials. Replace the entire subsection with the following:

The ingredients of the slurry shall conform to the following:

1) Emulsified asphalt shall be Polymer Modified cationic quick-set type, CQS-1h containing 2.5% minimum Ultrapave 65K styrene/butadiene/rubber latex as manufactured by Textile Rubber and Chemical Company or approved equal. CQS-1h shall conform to the requirement of 203-1.3 and the following specifications when tested according to appropriate ASTM methods:

TABLE 203-5.2(A)
CQS-1h QUICK SET EMULSION

Tests	ASTM Test	Requirements Min.	
Furol Viscosity @ 77°F, sec.	D244	15	100
Residue from distillation, % by weight	D244		60 Min.
Sieve Test, % retained on No. 20	D244		10 Max.
Particle Charge Test (Cationic)			Positive
Storage Stability; One-Day Settlement	D244		1% Max.
Residue			
Penetration 0.1 mm	D5	45	80
Solubility in TCE,	D2042		97.5 Min.
% Ductility, 77°F,	D113		40 Min.

Test for Polymer Content

Torsional Recovery, %	Caltrans 322	18.0 Min.
Polymer Solids Content, % by weight of Asphalt Solids	Caltrans 401	2.5 3.0

2) The Retarder for quick-setting emulsion and the asphalt modifier shall be a type approved by the Engineer. The amount of retarder and asphalt modifier to be included in the quick-set slurry shall be that amount necessary to ensure that the applied slurry can support vehicular traffic within 60 minutes after the last application.

3) Water shall be potable and compatible with the other ingredients of the slurry.

4) Aggregate shall be rock dust produced by the crushing of rock and gravel. The aggregate without any additive shall conform to the following requirements:

TESTS	ASTM METHOD	REQUIREMENTS
Percentage Wear 500 Revolutions ¹	C131	35% Maximum
Sand Equivalent	D2419	55 Minimum
Soundness (5 Cycles)	C 88	15% Maximum
¹ ASTM C131 to be run on plus four graded material before final crushing.		

- a) The Contractor shall provide an aggregate stockpile 24-hours prior to starting the work. Location to be approved by the Engineer if within City right-of-way.
- b) Contractor shall schedule and coordinate the delivery of aggregate to the stockpile(s) such that: (1) deliveries originate at the plant and arrive at the stockpile site within normal work hours on the same calendar day; (2) delivery site and project name are explicitly stated on each delivery ticket; (3) successive deliveries on the same calendar day show the cumulative total for that day; (4) copies of all delivery tickets shall be delivered to the Engineer before the end of the working day. Any delivery tickets not so delivered may be rejected by the CITY. Any deviation from this process must have the prior approval of the Engineer.
- c) The Contractor shall furnish calibrated vehicle weigh scales at the stockpile site for use by the CITY. The portable scales will be utilized for inspection and all mixers shall be weighed prior to transit. All equipment and tools necessary for field measurement of the emulsion and aggregate by the CITY shall be furnished and maintained by the Contractor.

The Contractor shall be responsible for the initial setup of the weigh scales at the stock-pile site and all necessary relocations during the slurry seal operations.

The cost to furnish the vehicle scales, all equipment, and tools necessary for field testing shall be included in the Contract Unit Price for the Emulsion Aggregate slurry and no additional compensation shall be allowed.

203-6 ASPHALT CONCRETE

The asphalt pavement class and grade shall be:

Base Course: B-PG 64-10

Asphalt Concrete Cap: C2-PG 64-10

SECTION 209 – PRESSURE PIPE

209-4 PVC PRESSURE PIPE.

209-4.1 General. Add the following:

PVC pipe shall comply with AWWA C900. Unless otherwise specified on the Plans or Specifications, the minimum pipe wall thickness shall be equal to Pressure Class 235.

SECTION 214 - TRAFFIC STRIPING, CURB AND PAVEMENT MARKINGS AND PAVEMENT MARKERS

All striping and markings on this project shall be thermoplastic per Section 214-5. Striping layout shall be restored to existing conditions.

SECTION 215 – MISCELLANEOUS POTABLE WATER DISTRIBUTION SYSTEM MATERIALS

215-1 VALVES.

215-1.1 General. All valves and gates shall be new and of recent manufacture. The flanges shall be plain faced and shall conform in dimensions and drilling to ANSI B16.1 Class 125 or ANSI/AWWA C153. Each valve body shall be tested to a pressure equal to twice its design water working pressure, except that gate valves shall be tested in accordance with the requirements of AWWA C500.

All interior parts of valves manufactured of bronze or brass except valve stems, shall conform to the requirements of ASTM B62. Gate valve stems shall be of bronze, containing not more than 5 percent of zinc, not more than 2 percent of aluminum, and having a minimum tensile strength of 60,000 psi, a yield strength of 40,000 psi, and elongation of at least 10 percent in two inches, as determined from a test coupon poured from the same ladle from which the valve stems to be furnished are poured.

Except as otherwise provided, all ferrous surfaces (excluding non-corrosive surfaces) in the water passages of all valves, 4 inch and larger, shall be fuse coated with an epoxy coating in accordance with AWWA C550. All buried valves shall be provided with an exterior protective coating.

Unless otherwise shown on the Plans, all in-line valves shall be furnished with mechanical ends.

215-1.2 Resilient-Seated Gate Valves. Gate valves, size 3 inches through 12 inches, shall be resilient seat, solid wedge, non-rising stem type equipped with “O” ring seals and conforming to AWWA C509. Gate valves shall be rated for 250 psi working pressure.

Valves shall have a 2-inch square operating nut or hand wheel, as shown on the Plans, and shall open with a counter-clockwise rotation of the operator.

Gate valves shall be Mueller A-2360 to match pipe size with flanged or mechanical ends.

215-1.8 Miscellaneous Small Valves. Miscellaneous small valves shall be as specified in the Plans or Specifications. Where not specifically labeled, valves smaller than 3-inch shall be lever-operated ball valves, as manufactured by The James Jones Company or approved equal.

215-1.9 Air and Vacuum Release Valves. Air and vacuum release valves shall be cast-iron body valves with bronze trim and stainless steel float. They shall be APCO No. 144 Air and Vacuum Release Valves as manufactured by Valve and Primer Corporation, Chicago, Illinois, or approved equal.

215-1.10 Abandoning existing valves. All existing valves shall be abandoned by Contractor unless otherwise noted on the plans. After pipelines have been tested and disinfected by Contractor, and accepted by City, and after City has completed all service connections and waterline connections, Contractor shall remove valve cans a minimum of 12" below finish grade, remove operating nut extensions, and fill valve cans with concrete. Thereafter, Contractor shall sawcut existing asphalt concrete pavement (2' square section) around existing valve boxes, remove said asphalt concrete pavement or concrete and dispose of same at a legal disposal site, and place concrete or asphalt concrete pavement over abandoned valve boxes. Valve box caps and extensions shall be returned to the City.

215-2 Fire Hydrants. Fire hydrants shall be as manufactured by The James Jones Company, Model J-3700 or J-3765 as shown on the Plans and shall conform to the requirements of AWWA C503. Each fire hydrant shall be assembled with a gray- iron 6-inch nominal diameter hydrant extension with break-away grooves and flanged ends, and a gray-iron 6- inch nominal diameter hydrant bury with top end flanged and bottom end having a mechanical joint connection. Flanges shall be 6-hole pattern. The hydrant flange shall be connected to the extension by means of breakaway bolts in accordance with AWWA C110.

215-2.1 Abandoning Existing Fire Hydrants.

- a. Existing fire hydrants shall be abandoned by Contractor unless otherwise noted on the plans. After pipelines have been tested and disinfected by Contractor, and accepted by City, Contractor shall remove fire hydrants and fire hydrant burys a minimum of 12" below finish grade and fill fire hydrant burys with concrete. Thereafter, Contractor shall sawcut existing concrete at construction joints around abandoned fire hydrant burys, remove said concrete and dispose of same at a legal disposal site, and place concrete over abandoned fire hydrant burys.

- b. If existing fire hydrants are located in an area without concrete, Contractor shall remove and replace in kind area around abandoned fire hydrant burys.
- c. Contractor shall restore landscaping and existing improvements around abandoned fire hydrants.
- d. Contractor shall notify City Fire Department of the location of the fire hydrants that are out of service.
- e. Hydrants to be delivered to the City of Lomita, Public Works Yard.

215-3 BLOW-OFF HYDRANTS. Blow-off hydrants shall be as manufactured by The John C. Kupferle Foundry Company, St. Louis, Missouri, Model Eclipse No. TF550 with 2-inch female iron pipe inlet. The Blow-off assembly shall include the 2" service line, 2" ball valve, and other appurtenances as indicated in City of Lomita Standard Plan W-124.

215-4 INSULATING COUPLINGS, BUSHINGS AND UNIONS. Insulating couplings, bushings and unions shall be furnished to provide dielectric protection from electrolytic corrosion at all points where piping and fittings of dissimilar metals are joined, as manufactured by Smith Blair; Corrosion Control Products, Co.; or approved equal. Couplings, bushings, and unions shall be lined with an inert, non-conductive, linen impregnated material and threaded to NPS standards, with sufficient separation between pipe ends to prevent bridging.

215-4.1 Insulating Flange Kits. Kits shall be furnished as shown on the Plans and shall consist of a dielectric gasket, insulating sleeves and washers.

- a) Gaskets. Gaskets shall be Type "E" neoprene faced phenolic material for operation between 20 and 150 degrees Fahrenheit per ANSI B16.21.
- b) Insulating Sleeves. Insulating sleeves shall be 1/32-inch thick, full length, CE phenolic tubing for operation between 20 and 150 degrees Fahrenheit. For installation at threaded valve flanges, the sleeves shall be half-length.
- c) Insulating Washers. Insulating washers shall be laminated CE phenolic for operation at ambient temperatures to be placed directly adjacent to the flange face.

Moisture, soil, or other foreign matter must be carefully prevented from contacting any portion of the mating surfaces prior to installing insulator gasket. If moisture, soil, or other foreign matter contacts any portion of the surfaces, the entire joint shall be disassembled, cleaned with a suitable solvent, and dried prior to re-assembly.

215-5 SERVICE LATERALS. New service laterals shall be Type K soft copper and shall conform to City of Lomita Standard Plan Nos. W-101, W-102, and W-103. Sizes of service laterals to be installed are as shown on the Plans.

No joints shall be made in service lateral runs without the Engineer's approval. All joints so allowed shall be silver-solder joints.

215-6 FLEXIBLE COUPLINGS. Unless otherwise specified, flexible couplings shall conform to the following:

- 1) Each coupling shall consist of one steel middle ring, two steel followers, gaskets, and sufficient numbers of Type 316 stainless steel bolts to compress the gasket without distorting the followers.
- 2) The thickness of the middle ring shall be such that the stress in the steel shall not exceed 50 percent of the yield point when subjected to the hydrostatic test pressure of the pipeline. The pressure rating shall be no less than the indicated design pressure. The middle ring thickness shall not be less than the thickness of the pipe jointed.
- 3) Middle rings shall be cold expanded a minimum of one-percent increase in diameter to test the weld and the size of the proper dimension.
- 4) The middle rings shall be coated with Keysite 740 or approved coating to a minimum dry film thickness of 10 mils. Follower rings shall be coated with a compatible shop coat for field coating.
- 5) Bolts shall be 5/8-inch diameter carriage bolts with hexagon nuts. The steel shall have minimum yield strength of 40,000 psi.
- 6) Buried coupling shall be coated with fusion bonded epoxy and provided with Type 316 stainless steel bolts and nuts.
- 7) Provide thrust ties where shown and where required to restrain the force developed by 1-1/2 times the operating pressures specified. Attach thrust ties to ductile iron pipe with socket clamps against a grooved joint coupling or flange.
- 8) Flexible couplings shall be by one of the following manufacturers: Baker, Dresser, Rockwell or Ford.

PART 3 - CONSTRUCTION METHODS

SECTION 300 – EARTHWORK

300-1 CLEARING AND GRUBBING.

300-1.1 General. Replace the entire subsection with the following:

Unless otherwise stated on the Plans or Specifications, all material removed from the Work shall become the property of the Contractor and shall be disposed of in a lawful manner. Removals shall include, but not limited to, all excess excavation material, trees and plants, debris, interfering portions of curb, gutters, asphalt and PCC concrete pavements and sidewalks (including base, where applicable), and miscellaneous items as shown on the Plans. The Contractor shall conform to the following requirements:

- 1) The Contractor shall not start any removal work unless it is prepared to perform reconstruction work within 24 hours of the time removals were begun, unless otherwise approved by the Engineer.
- 2) The Contractor shall complete forming and pouring of PCC construction within five (5) working days following the removal of existing material at any location.
- 3) The Contractor shall not remove on-site improvements until it is prepared to construct the adjacent street section and shall promptly restore all such improvements as applicable, upon completion of the adjacent street work.

All concrete removed shall be hauled off the Work site no later than the calendar day following the day that the removal is performed.

The limits for sidewalk, curb and gutter and driveway shown on the plans are approximate. The actual removal and/or construction limits shall be as marked and/or directed by the Engineer in the field.

In order to protect the public streets from deterioration due to hauling of materials, the Contractor shall submit, prior to the Pre-Construction Meeting, for approval a proposed route for hauling of materials for disposal. Upon approval, the Contractor shall strictly adhere to that route, unless written permission from the Engineer is obtained to change the route.

Add the following subsection:

300-1.5 CONSTRUCTION AND DEMOLITION DEBRIS RECYCLING.

GENERAL. Consistent with the City's efforts to comply with the California Integrated Waste Management Act of 1989 (AB 939), the Contractor shall reduce, reuse, and/or recycle to the maximum extent feasible, the construction and demolition debris (debris) generated by this

Contract hereby diverting the debris from disposal facilities, saving landfill space, and conserving virgin materials and natural resources.

RECYCLING SUMMARY. The Contractor shall file with the City Engineer, prior to the acceptance of the work, a Recycled Materials Certificate using the Recycling Summary form on Appendix III. The Recycled Materials Certificate shall list all recycled materials used in connection with work or delivered off-site for recycling. Certificate shall include for each recycled material type: a) Material description, b) Material quantity, c) Method of measurement, d) Material origination location, e) Material deposition location.

UNCLASSIFIED EXCAVATION.

300-2.2 Unsuitable Material.

300-2.2.1 GENERAL. Add the following:

Unclassified excavation shall include excavating, removing, hauling, and disposal of all material including asphalt concrete pavement to the subgrade elevations indicated on the plans as required to construct the new improvements. Removal of asphalt concrete, aggregate base, and native soil shall be made at the locations shown on the plans, or as specified in the field by the Engineer.

If unsuitable material is found, the Contractor shall remove said material to the limits to be determined by the Engineer and shall replace said material with select fill or base material, as to be determined by the Engineer.

Payment for unsuitable material excavation and backfill shall be measured and paid for as Unclassified Excavation and Crushed Aggregate Base, respectively.

SECTION 301 – SUBGRADE PREPARATION, TREATED MATERIALS, AND PLACEMENT OF BASE MATERIALS

301-1 SUBGRADE PREPARATION

301-1.6 Adjustment of Manhole Frame and Cover Sets to Grade - Add the following:

All surface utility covers (even those to be adjusted to grade by others) shall be located in the field prior to beginning any work on this project. The Contractor shall remove existing concrete pads or collars that might interfere with the adjustment of the valve cover to the grade of the asphalt concrete surface. Any damage to existing utility systems or appurtenances by the Contractor shall be replaced at the Contractor's expense.

The Contractor shall also be responsible for coordinating his work with the various utility agencies that will be required to adjust their own surface utility covers to grade as noted on the plans. This includes tying out their covers and notifying all surface utility agencies prior to performing any work that will affect their facilities. If the required adjustment of the agency

adjusted utility covers will impact the Contractor's subsequent work then the Contractor shall coordinate his work schedule and/or perform follow up work to ensure that the quality of the final product is not compromised.

Refer to subsection 301-1.6.1 of these Special Provisions for adjustment of Los Angeles County Sanitation District manhole covers. Other surface utility covers within the area to be paved or graded shall be set to finish grade by the Contractor in accordance with 302-5.8 unless otherwise specified.

301-1.6.1 ADJUSTMENT OF LOS ANGELES COUNTY SANITATION DISTRICT (CSD) MANHOLES TO GRADE.

When County Sanitation Districts (CSD) manholes must be adjusted to new grade, the work will be done by CSD in conjunction with the Contractor pursuant to the following procedures:

1. The Contractor shall notify CSD's Superintendent of Maintenance at (310)638-1161 a minimum of three (3) working days prior to the start of any work involving CSD manholes.
2. If grade over manhole is to be lowered:
 - a. The Contractor shall furnish and deliver a temporary steel cover plate of adequate thickness and size approved by CSD for the manhole.
 - b. The Contractor shall excavate around the manhole to a depth and distance outside of the manhole as required for CSD to remove the manhole frame and cover.
 - c. CSD will remove the manhole frame and cover and the interfering portion of the manhole shaft and place the cover plate over the manhole.
 - d. The Contractor shall store and protect the frame and cover and fill and/or pave over the cover plate to final grade.
 - e. The Contractor shall remove the pavement and/or fill as required for CSD to raise the manhole to final grade. Pavement and/or fill shall be removed to a minimum depth of not less than 6 inches below final grade and 12 inches around the manhole if the cover plate is more than 6 inches below final grade.
 - f. CSD will raise the manhole and set the frame and cover to final grade.
 - g. The Contractor shall backfill and compact and complete the pavement around the manhole.
3. If grade over manhole is to be raised:
 - a. The Contractor shall fill and/or pave directly over the manhole frame and cover to final grade.
 - b. Repeat steps e. through g. of Item 2 above.

The Contractor shall be responsible for furnishing, placing, and maintaining barricades and lights as necessary to protect the public from danger due to the work being performed.

301-1.7 Payment. Replace the first last three paragraphs with the following:

Payment for adjusting sewer or storm drain manhole frames and covers to grade shall be made at the Contract Unit Price per Each for Adjust Existing Utility Manholes to New Grade and shall include all labor, tools, equipment, and materials necessary for doing the work. No other compensation will be allowed.

SECTION 306 – OPEN TRENCH CONDUIT CONSTRUCTION

306-1 GENERAL. Add the following:

All trenches shall be sawcut to the bottom of the existing concrete or asphalt section to minimize damage to adjacent pavement. The bottom of the trench shall be excavated uniformly to the grade of the bottom of the pipe and shall be given a final trim using a string line for establishing grade, such that each pipe section when first laid will be continually in contact with the ground along the extreme bottom of the pipe.

Tunneling shall be performed under existing curb, gutter and cross-gutter as shown on the Plans. The Contractor shall exercise caution and care to prevent any damage in tunneling under these structures. There shall be no additional payment for this tunneling work. Payment for this work shall be included in the Contract Unit Price for the installation of the main pipeline, Meter Installation, Air/Vacuum Valve Assembly, or Blow-off Valve Assembly as appropriate.

306-3.3 REMOVAL AND ABANDONMENT OF EXISTING CONDUITS AND STRUCTURES.

Add the following:

306-3.3.1 ABANDONING EXISTING WATER MAINS. The Contractor shall remove existing water mains and appurtenances from service at the locations shown on the Plans or as directed by the Engineer. Water mains specified to be abandoned in place, 12 inches in diameter and larger shall be filled with cement grout and have their ends cut, plugged and capped. Water mains specified to be abandoned in place, 10 inches in diameter and smaller shall have their ends cut, plugged with concrete, capped and left intact.

306-3.3.2 ABANDONING WATER SERVICES. The Contractor shall abandon water services at the locations as shown on the Plans and in accordance with the following requirements:

- 1) The Contractor shall cut and disconnect, at the meter boxes and at the mains, all existing service lines, which are connected to the existing water mains to be abandoned in place.
- 2) The Contractor shall remove the meter and deliver to the City yard.
- 3) The Contractor shall remove and dispose of the existing meter box.
- 4) All existing corporation stops shall be turned off, service lines disconnected and corporation stops capped.

- 5) The Contractor shall backfill the cavity and restore the surface to match the surroundings.

306-3.4 MAXIMUM LENGTH OF OPEN TRENCH

Contractor shall excavate open trench 100 feet ahead of pipe laying operations to allow any adjustment in grade necessary to resolve unforeseen utility conflicts.

All trenches shall be backfilled and have 3" temporary pavement installed or covered with steel traffic rated plated each working day, The last twenty (20) feet of each trench may be open provided that this length is covered with traffic rated plating. Steel plates shall be non-skid and shall be tacked down or spiked and placed flush with the surrounding pavement. The Contractor shall be required to place temporary AC at the edges of the steel plates.

APPENDIX I

CONSTRUCTION AND DEMOLITION DEBRIS RECYCLING SUMMARY

CONSTRUCTION AND DEMOLITION DEBRIS RECYCLING SUMMARY

Project Type: Roadway and/or Bridge/Structure Water/Sewer
 Traffic Signal/Street Lighting Other _____

Project Name: _____ Date: _____

City Contract No. _____

Project Location: _____

Thomas Guide Page/Grid No(s): _____

Contractor Name: _____

Contractor Address: _____

Contractor License #: _____

Project Duration: From: _____ To: _____

Demolition and Recycling Cost: \$ _____

Type(s) of Debris Generated	Total Quantity Generated (tons, c.y. or units)	Reuse /Recycling		Disposal	
		Total Quantity (tons, c.y. or units)	Name of Reuse/Recycling Facility/Site	Total Quantity (tons, c.y. or units)	Name of Disposal Facility
Asphalt					
Brick					
Concrete					
Green Waste					
Metal (ferrous)					
Metal (non-ferrous)					
Mixed Debris					
Rock					
Soil					
Wood Waste					
Other:					
Total					

Notes:

- Other debris types may include, but are not limited to, Ash, Cardboard, Carpeting, Glass, Gravel, Land Clearing Debris, Non-friable Asbestos, Paper, Plastic, Porcelain, Roofing Material, Sand, and Tires. Attach additional sheets if necessary.
- If the debris is taken to a transfer station solely for the purpose of reuse/recycling, then list the transfer station as the reuse/recycling facility/site.
- If the debris is taken to a transfer station solely for the purpose of transfer to a disposal facility, then list the transfer station as the disposal facility.

Prepared by _____ Signature _____ Phone #: _____

APPENDIX II

CITY BUSINESS LICENSE APPLICATION



CITY OF LOMITA

24300 NARBONNE AVENUE • LOMITA, CA 90717 • OFFICE (310) 325-7110 • FAX (310) 325-4024

BUSINESS LICENSE APPLICATION

BUSINESS NAME _____

BUSINESS ADDRESS _____
(P.O. Box NOT Allowed)

MAILING ADDRESS _____

BUSINESS PHONE () _____

DESCRIBE EXACT NATURE OF BUSINESS: _____

OFFICIAL USE ONLY

LICENSE ID: _____

EXP DATE: _____

ISSUING CLERK: _____

TOTAL PAID: \$ _____

CASH CHECK CHARGE

OWNERSHIP: CORPORATION SOLE PROPRIETOR PARTNERSHIP TRUST

RESALE/SELLERS NO. _____ FEDERAL I.D. NO. _____ STATE I.D. NO. _____

CONTRACTORS STATE LICENSE NO. _____ LICENSE TYPE _____ EXP DATE _____

Enter below names of Owner, Partner, or Corporate Officer (if applicable, please provide a copy of Articles of Inc)

OWNER NAME _____ PHONE () _____

HOME ADDRESS _____

SOCIAL SECURITY NO. _____ DRIVERS LICENSE NO. _____

ESTIMATED GROSS RECEIPTS BUSINESS TAX FEE DUE FOR NEXT 12 MONTHS \$ _____

NOTICE

BUSINESS CERTIFICATES ARE ISSUED PENDING THE APPROVAL OF ANY OR ALL OF THE BELOW NAMED REGULATORY DEPARTMENTS. PRELIMINARY FILING OF THIS APPLICATION DOES NOT CONSTITUTE EVIDENCE THAT THE ABOVE DESCRIBED BUSINESS HAS MET THE REQUIREMENTS OF THE CITY OF LOMITA MUNICIPAL CODE. I DELARE UNDER PENALTIES OF PERJURY THAT THIS APPLICATION AND ANY ATTACHMENTS THERETO, HAVE BEEN EXAMINED BY ME, AND THE BEST OF MY KNOWLEDGE AND BELIEF REPRESENT TRUE, CORRECT AND COMPLETE STATEMENT OF FACTS.

APPLICANT SIGNATURE _____ DATE _____

CITY DEPARTMENTS	APPROVAL	INITIALS	DATE
CITY MANAGER	<input type="checkbox"/> YES <input type="checkbox"/> NO		
PLANNING	<input type="checkbox"/> YES <input type="checkbox"/> NO		
CODE ENF	<input type="checkbox"/> YES <input type="checkbox"/> NO		
HEALTH DEPT	<input type="checkbox"/> YES <input type="checkbox"/> NO		
FIRE DEPT	<input type="checkbox"/> YES <input type="checkbox"/> NO		

CITY MANAGER	<input type="checkbox"/> YES <input type="checkbox"/> NO
PLANNING	<input type="checkbox"/> YES <input type="checkbox"/> NO
CODE ENF	<input type="checkbox"/> YES <input type="checkbox"/> NO
HEALTH DEPT	<input type="checkbox"/> YES <input type="checkbox"/> NO
FIRE DEPT	<input type="checkbox"/> YES <input type="checkbox"/> NO

APPENDIX III

CITY OF LOMITA
WATER STANDARD PLANS

APPENDIX IV

CITY OF LOS ANGELES

U PERMIT

APPENDIX V

CALTRANS
ENCROACHMENT PERMIT



Public Works Department
24300 Narbonne Avenue
Lomita, CA 90717
310/325-7110

NOTICE OF EXEMPTION

Project Description:

247th Street Area Water Main Replacement – This project consists of abandoning a watermain that runs north and south within private properties crossing 246th Street, 247th Street, 247th Place, and 248th Street. The proposed new water main will extend from 246th Street beyond the City boundaries, looping within the City of Los Angeles right of way and along Western Avenue (which is Caltrans right of way), and connecting back to the City of Lomita along 247th Street, 247th Place, 248th Street and Lomita Blvd. This project consists of constructing approximately 3,300 linear feet of PVC water pipeline and appurtenances (fire hydrants, valves, services, and fittings). The existing pipeline located in private property will be abandoned. The new main will provide the same capacity.

Finding:

The City Council of the City of Lomita has reviewed the above proposed project and finds it to be exempt from the provisions of the California Environmental Quality Act (CEQA).

- Ministerial Project
- Replacement or Reconstruction of existing structures and facilities, Exemption (CEQA Guidelines, Section 15302 Class 2)
- Statutory Exemption
- Emergency Project
- Quick Disapproval [CEQA Guidelines, Section 15270]
- No Possibility of Significant Effect [CEQA Guidelines, Section 15061(b)(3)]

Supporting Reasons In accordance with Section 15302 Replacement or Reconstruction, Class 2 consist of replacement of existing structure or facilities where the new facilities will be located on the same site as the old structure replaced and will have substantially the same purpose and capacity as the structure replaced. Per this California Environmental Quality Act (CEQA) Guidelines, the installation and use of the new underground pipe will be to supply water to the same customers, replacing old 1928 pipes and providing the same water capacity.

<p>9/19/23 (Date)</p>	<p> Carla Dillon, Director of Public Works</p>
---------------------------	--